

veam

# VBN Connectors



**ITT**

ENGINEERED FOR LIFE

## PROVEN QUALITY, RELIABILITY AND EXPERTISE.

ITT's Veam brand is a leading global manufacturer of connector products serving international customers in multiple end markets. In an increasingly global economy, getting from Point A to Point B on time and on budget is more

important than ever. Veam connectors protect the world's products and people in transit so they can get to where they're going with maximum efficiency.



Engineered with your toughest challenges in mind.

### About ITT

ITT is a diversified leading manufacturer of highly engineered critical components and customized technology solutions for the energy, transportation and industrial markets. Building on its heritage of innovation, ITT partners with its customers to deliver enduring solutions to the key industries that underpin our modern way of life. Founded in 1920, ITT is headquartered in White Plains, N.Y., with employees in more than 35 countries and sales in a total of approximately 125 countries. For more information, visit [www.itt.com](http://www.itt.com).

Dimensions shown in mm  
Specifications and dimensions subject to change



- The VBN connector series is based on MIL-DTL-5015G and VG95234 specification. They are interchangeable with all corresponding CIR/VG types and feature identical panel mounting dimensions
- VBN connectors are available in 15 sizes arrangements from shell size 16S to shell size 40 with arrangements having from 4 up to 70 contacts.  
Out of this range, 14 sizes arrangements are qualified to NF F 61-030 French specification and approved by SNCF and RATP (from 4 to 60 contacts).
- The contact system enables easy insertion and removal. The inserts are composed of a halogen free hard plastic material that results in a very low fire hazard.
- Stainless steel bayonet pins riding along the three Bayonet ramps (machined into the receptacle shell) achieve the connector coupling. Coupling integrity is guaranteed by:
  - Three stainless steel pins at the critical wear points of the receptacle shell bayonet ramps
  - An audible click when fully mated.
  - Alignment of three yellow colored dots when fully mated.
- Crimp contacts are available in sizes 16, 12 and 8 AWG.
- The stainless steel pins installed on the critical wear points of the ramps, the dynamic coupling gasket at the base of the plugshell, the flat and the wave washer between the coupling nut and the plugshell, are the key features that allow to prevent the unmating of the connection in case of vibration and guarantees the high reliability of the bayonet mating system.
- Environmental sealing of mated connectors to IP67 is achieved by compression of the coupling gasket, while integrity at the rear is achieved by the use of an individual wire seal grommet with membranes (being penetrated only when a wire is present) and use of appropriate accessories.
- Comprehensive range of screened / unscreened, sealed / unsealed backshells & accessories

Dimensions shown in mm  
Specifications and dimensions subject to change

## TABLE OF CONTENTS

---

Technical information	5	Receptacle - 90 degrees	21
Components description	6	Plug - straight	26
Order code	7	Plug - 90 degrees	34
Version overview	8	Shielded connectors	39
Inserts arrangements	9	Spares backshells	43
Contacts - pin contacts	11	Accessories	51
Contacts - socket contacts	12	Application notes	59
Receptacle - straight	13		

---



Dimensions shown in mm  
Specifications and dimensions subject to change

## MATERIAL CONSTRUCTION

**Shells:** Aluminum alloy

**Available Platings:** T108: Black Zn/Co - 200 H Salt Spray - Conductive  
T240: Blue Zn/Ni - 500 H Salt Spray - Conductive  
T39: Black epoxyurethanic coating - 500 H Salt Spray - Non Conductive

**Insulator:** Low fire hazard thermoplastic.

**Interfacial Seal & Grommet:** Low fire hazard silicone rubber

**Contacts:** Copper alloy with gold or silver (on request, not according NFF standard) plating.

## ENVIRONMENTAL PERFORMANCE

**Operating Temperature:** -40°C to +100°C per NF F 61-030

**Corrosion Resistance:** T108: Black Zn/Co - 200 H Salt Spray - Conductive  
T240: Blue Zn/Ni - 500 H Salt Spray - Conductive  
T39: Black epoxyurethanic coating - 500 H Salt Spray - Non Conductive

**Water Protection:** IP67 in mated condition when used with proper backshell and accessories

**Fluid Resistance:** Gas, oil, mineral oil, acid bath per NF F 61-030

**Fire and smoke:** - acc. to NFF 16-101 & 16 - 102 (exigence 2)  
- UL94v0 compliant

## MECHANICAL PERFORMANCE

**Durability:** 500 mating cycles minimum

**Bayonet Coupling Torque:** Per VG95234

**Shock:** 30g - 18 ms.

**Vibration:** 2g / 10-100Hz or 5g / 25-250Hz (NF F 60-002 / NF C 93-400).

**Min. Retention force:** 70N for contacts #16

**of the contact in:** 90N for contacts #12

**the insulator:** 110N for contacts #8

## ELECTRICAL PERFORMANCE

**Insulation Resistance:** 5000 MOhm

**Rated voltage:** 380Vac / 500Vdc per NF F 61-030

**Withstanding Voltage:** 3250 VAC rms per NF F 61-030

**Creepage/Clearance distance:** 12mm / 8mm min. (In mated conditions, interfacial seal in compression)

**Contact Rating:** See table

Layout	Shell Size	Contacts Size	No of Contacts	Rated Current (*) A		Contact Resistance mΩ max.
				Single cont.	Grouped cont.	
16S-1	16S	16S	7	15	12	2.5
18-19	18	16	10	15	12	2.5
20-15	20	12	7	23	20	1.3
20-4	20	12	4	23	22	1.3
20-7	20	16	8	15	14	2.5
22-14	22	16	19	15	11,5	2.5
22-23	22	12	8	23	20	1.3
24-10	24	8	7	46	33	0.9
28-21	28	16	37	15	12	2.5
32A-13	32	12	13	23	18	1.3
36-10	36	16	48	15	7,5	2.5
36A-22	36	12	22	23	19	1.3
40A-35	40	12	35	23	15,5	1.3
40A-60	40	16	60	15	9	2.5

(\*) Acc. To NF F 61-030. Max heating allowed: 50°C

- Single contact: loaded into insulator. - Grouped contacts: fully populated insulator, all contacts loaded.

# VBN COMPONENTS DESCRIPTION

## PANEL MOUNTED CONNECTOR

---

**Flange** - holds the insert and incorporates an alignment key to position the insert. The Flange accommodates either the socket or pin insert to reverse gender. Bayonet Coupling ramps provide cam action for coupling and uncoupling with the plug connectors. Stainless steel pins, at the top of the ramps, ensure positive locking and long service life.

**Insert (pin or socket)** - Removable, orientable, retains the contacts and can be used in either Flange or plugshells.

**Contacts (pin or socket)** - Suitable to be crimped with the wire conductors.

**Circlip Retaining Ring** - Retains the insert into the shell.



## PLUG CONNECTOR

---

**Coupling nut** - Provides cam force when mating and un-mating mechanical system for coupling and uncoupling of the connectors.

**Plugshell** - Holds the insert and incorporates an alignment key to position the insert. The plugshell accommodates either the socket or pin insert to reverse gender.

**Insert (pin or socket)** - Removable, orientable, retains the contacts and can be used in either Flange or plugshells.

**Circlip Retaining Ring** - Retains the insert into the shell.

**Contacts (pin or socket)** - Suitable to be crimped with the wire conductors



VEAM	3	( )	20	15	P	N	TXX	( )
------	---	-----	----	----	---	---	-----	-----

### Connector Series

- VEAM VEAM Bayonet Coupling N Series
- VBNG\* Plug

### Connector Type

- 2 Front Mounting Receptacle
- 3 Rear Mounting Receptacle
- 38 90° Rear Mount Receptacle
- 6 Straight Plug Connector
- 8 90° Plug Connector

### Connector Class

- A, R Straight or Right Angle, no Strain relief
- AF, F, CF, CFZ Straight or Right Angle with Strain relief
- APG, RPG Straight for use with PG fitting
- SS Backshells for shielded cable

### Shell Size

- 16S, 18, 20, 22, 24, 28, 32, 36, 40

### Insert Arrangement

Refer to pages 9 and 10

### Contact Gender

- P Male Contacts (Pin)
- S Female Contacts (Sockets)

### Insert Orientation

- N Normal
- W, X, Y, Z Degree for alternate positions - refer to page 10
- No Letter Insulation Not Installed

### Shell Plating

- TXX See available platings page 5

### Modification Code

Consult Factory

\*To be used only with Connector Type "6" and Connector Class "SS"

# VBN VERSION OVERVIEW

RECEPTACLE & PLUG	SEALING	STRAIGHT VERSIONS	RECEPTACLE & PLUG	SEALING	90° VERSIONS
		 <p>CLASS AV / RV Short backshell ext. thread</p>			 <p>CLASS A / R Standard backshell ext. thread</p>
 <p>VBN 2 Front Panel</p>		 <p>CLASS A / R Standard backshell ext. thread</p>	 <p>VBN 2 Front Panel</p>		 <p>CLASS APG / RPG Standard backshell int. PG thread</p>
 <p>VBN3 Rear panel mounting</p>	 <p>With Grommet</p>	 <p>CLASS APG / RPG Standard backshell int. PG thread</p>	 <p>VBN3 Rear panel mounting</p>	 <p>With Grommet</p>	 <p>CLASS AF / F Standard backshell with "A" cable clamp</p>
 <p>Plug - VBN6</p>	 <p>Without Grommet</p>	 <p>CLASS AF / F Standard backshell with "A" cable clamp</p>	 <p>Plug - VBN6</p>	 <p>Without Grommet</p>	 <p>CLASS CF / CFZ Standard backshell with "C" cable clamp</p>
 <p>Plug - VBN6-GG</p>		 <p>CLASS CF / CFZ Standard backshell with "C" cable clamp</p>	 <p>Plug - VBN6-GG</p>		 <p>CLASS SS / RSS Backshell with shielding system</p>
		 <p>CLASS SS / RSS Backshell with shielding system</p>			 <p>CLASS SS / RSS Backshell with shielding system</p>

Dimensions shown in mm  
Specifications and dimensions subject to change

## CONTACT LAYOUTS

Front View of the Male Insert

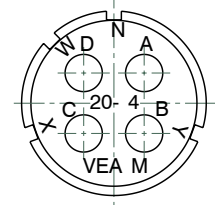
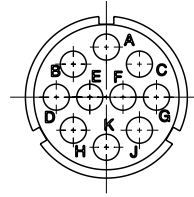
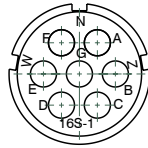

Layout	16S-1	18-19	20-4
# of contacts	7	10	4
Contact Size	16	16	12

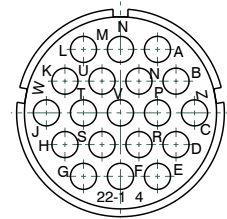
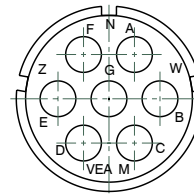
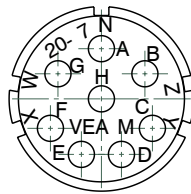

Layout	20-7	20-15	22-14
# of contacts	8	7	19
Contact Size	16	12	16

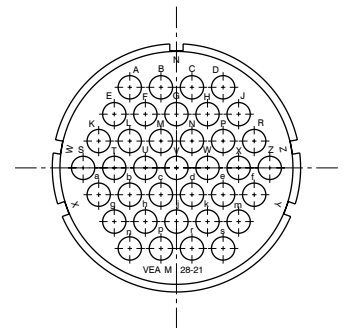
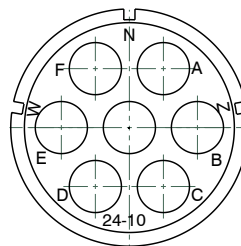
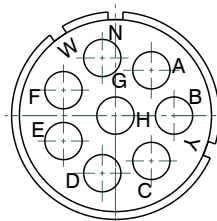

Layout	22-23	24-10	28-21
# of contacts	8	7	37
Contact Size	12	8	16

Dimensions shown in mm  
Specifications and dimensions subject to change

# VBN INSERT ARRANGEMENTS

## CONTACT ARRANGEMENTS

Front View of the Male Insert

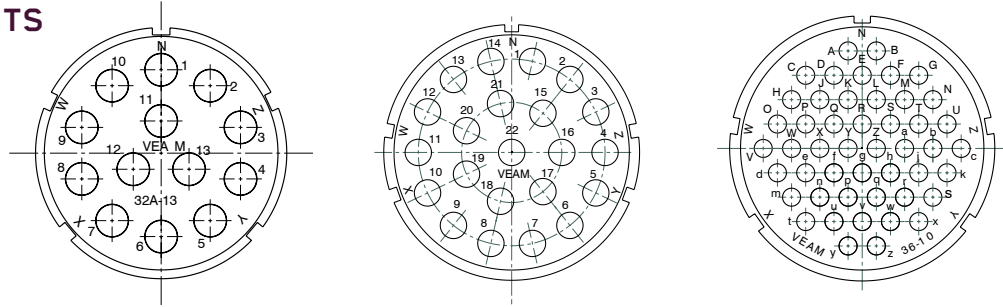

Layout	32A-13	36A-22	36-10
# of contacts	13	22	48
Contact Size	12	12	16

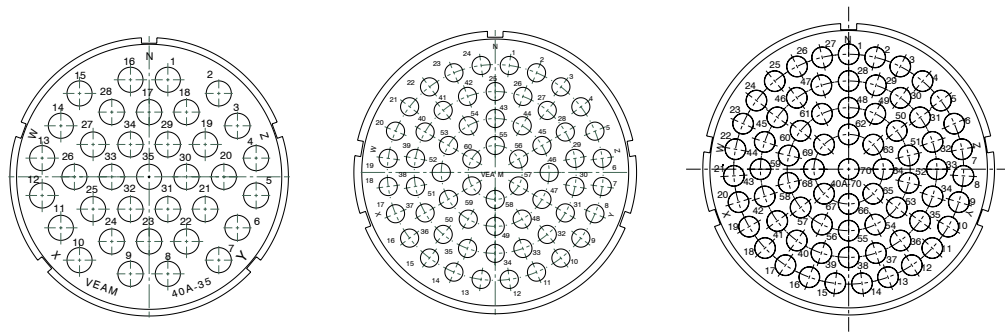

Layout	40A-35	40A-60	40A-70
# of contacts	35	60	70
Contact Size	12	16	16

## KEYING SYSTEM

Front view of male insert - Insert rotation

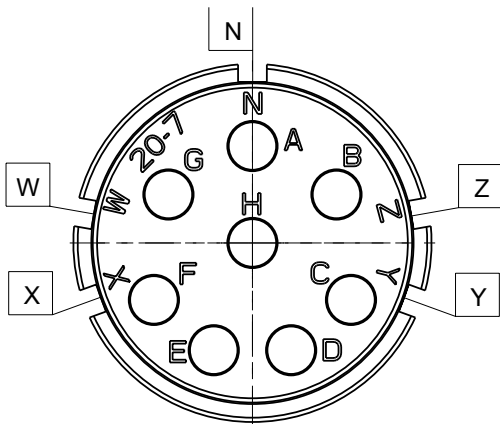

Insert Layout	Degrees for alternate positions				
	N	W	X	Y	Z
16S-1	0	80			280
18-19	0		120	240	
20-4	0	45	110	250	
20-7	0	80	110	250	280
20-15	0	80			280
22-14	0	80			280
22-23	0	35		250	
24-10	0	80			280
28-21	0	80	110	250	280
32A-13	0	65	130	230	295
36-10	0	80	125	235	280
36A-22	0	80	110	250	280
40A-35	0	70	130	230	290
40A-60	0	80	110	250	280
40A-70	0	80	110	250	280

Dimensions shown in mm  
Specifications and dimensions subject to change

**PIN CONTACTS**

Male contact to be used on connector with male insulator.

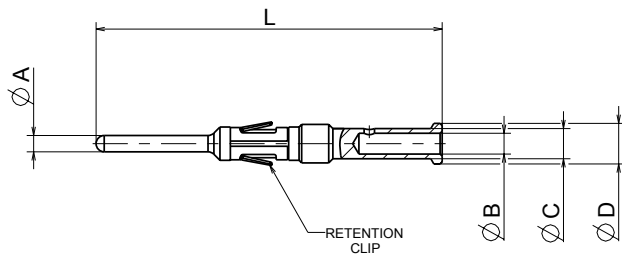

**Shape type 1**

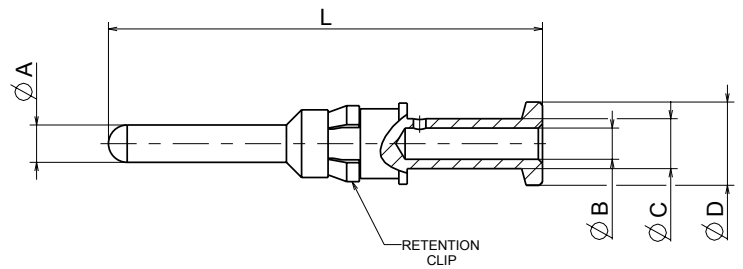

**Shape type 2**

Male Part number	Size	Wire Size		L	ØA	ØB	ØC	ØD	Cable O.D. max. (2 - 3)	Type
		mm2	AWG							
51513-16S-12T12	16S	0.5-0.75	20	28.1	1.58	1.2	2.6	3.9	3.8	1
51513-16S-20T12	16S	1.0-2.0	16	28.1	1.58	2.0	2.9	3.9	3.8	1
51513-16S-26T12	16S	2.5-3.0	12	28.1	1.58	2.5	3.8	3.8	3.8	1
51513-16-12T12	16	0.5-0.75	20	33.2	1.58	1.2	2.6	3.9	3.8	1
51513-16-20T12	16	1.0-2.0	16	33.2	1.58	2.0	2.9	3.9	3.8	1
51513-16-26T12	16	2.5-3.0	12	33.2	1.58	2.5	3.8	3.8	3.8	1
51513-12T12	12	2.5-3.0	12	38.5	2.38	2.5	3.8	5.5	5.4	1
51513-12-12T12	12	0.5-0.75	20	38.5	2.38	1.2	2.6	5.5	5.4	1
51513-12-20T12	12	1.0-2.0	16	38.5	2.38	2.0	3.8	5.5	5.4	1
51513-12-30T12	12	4.0	12	38.5	2.38	3.0	4.8	5.5	5.4	1
51513-12-38T12	12	6.0	10	38.5	2.38	3.6	4.8	5.5	5.4	1
51513-8T12	8	AWG 8	8	41.7	3.60	4.6	6.8	8.0	7.8	2
51513-8-20T12	8	1.0 - 2.0		41.7	3.60	2.0	3.8	8.0	7.8	2
51513-8-26T12	8	3.0		41.7	3.60	2.5	3.8	8.0	7.8	2
51513-8-30T12	8	4.0		41.7	3.60	3.0	4.8	8.0	7.8	2
51513-8-38T12	8	6.0		41.7	3.60	3.6	4.8	8.0	7.8	2
51513-8-50T12	8	10		41.7	3.60	5.0	7	8.0	7.8	2

NOTES: 1. Finish: Silver plating on size 12 and 8 also available (please consult factory).  
 2. The dimensions indicated are the maximum OD cable permitted, due to the rear insert holes.  
 3. When grommets are used refer to page 50 for cable dimensions.

# VBN CONTACTS

## SOCKET CONTACTS

Female contact to be used on connector with female insulator.

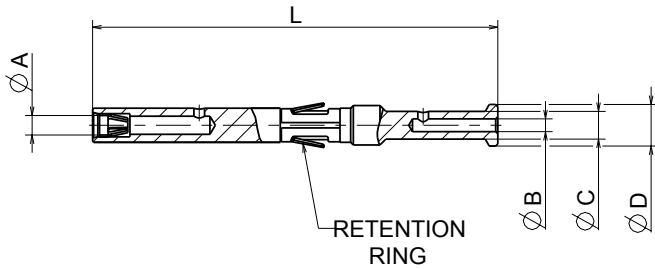

Shape type 1

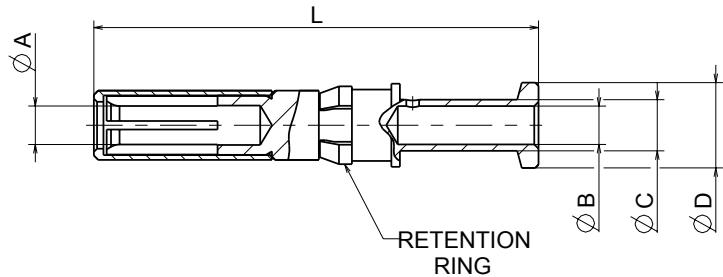

Shape type 2

Female Part number	Size	Wire Size mm <sup>2</sup>	AWG	L	ØA	ØB	ØC	ØD	Cable O.D. max. (2 - 3)	Type
51511-16S-12T12	16S	0.5-0.75	20	28.1	1.58	1.2	2.6	3.9	3.8	1
51511-16S-20T12	16S	1.0-2.0	16	28.1	1.58	2.0	2.9	3.9	3.8	1
51511-16S-26T12	16S	2.5-3.0	12	28.1	1.58	2.5	3.8	3.8	3.8	1
51511-16-12T12	16	0.5-0.75	20	33.2	1.58	1.2	2.6	3.9	3.8	1
51511-16-20T12	16	1.0-2.0	16	33.2	1.58	2.0	2.9	3.9	3.8	1
51511-16-26T12	16	2.5-3.0	12	33.2	1.58	2.5	3.8	3.8	3.8	1
51511-12T12	12	2.5-3.0	12	38.5	2.38	2.5	3.8	5.5	5.4	1
51511-12-12T12	12	0.5-0.75	20	38.5	2.38	1.2	2.6	5.5	5.4	1
51511-12-20T12	12	1.0-2.0	16	38.5	2.38	2.0	3.8	5.5	5.4	1
51511-12-30T12	12	4.0	12	38.5	2.38	3.0	4.8	5.5	5.4	1
51511-12-38T12	12	6.0	10	38.5	2.38	3.6	4.8	5.5	5.4	1
51511-8T12	8	AWG 8	8	41.7	3.60	4.6	6.8	8.0	7.8	2
51511-8-20T12	8	1.0 - 2.0		41.7	3.60	2.0	3.8	8.0	7.8	2
51511-8-26T12	8	3.0		41.7	3.60	2.5	3.8	8.0	7.8	2
51511-8-30T12	8	4.0		41.7	3.60	3.0	4.8	8.0	7.8	2
51511-8-38T12	8	6.0		41.7	3.60	3.6	4.8	8.0	7.8	2
51511-8-50T12	8	10		41.7	3.60	5.0	7	8.0	7.8	2

NOTES: 1. Finish: Silver plating on size 12 and 8 also available (please consult factory).  
 2. The dimensions indicated are the maximum OD cable permitted, due to the rear insert holes.  
 3. When grommets are used refer to page 50 for cable dimensions.

Dimensions shown in mm  
 Specifications and dimensions subject to change

# VBN RECEPTACLE



## VBN2--

Front panel mounting receptacle with through fixing holes and a threaded rear end.

Supplied without accessories

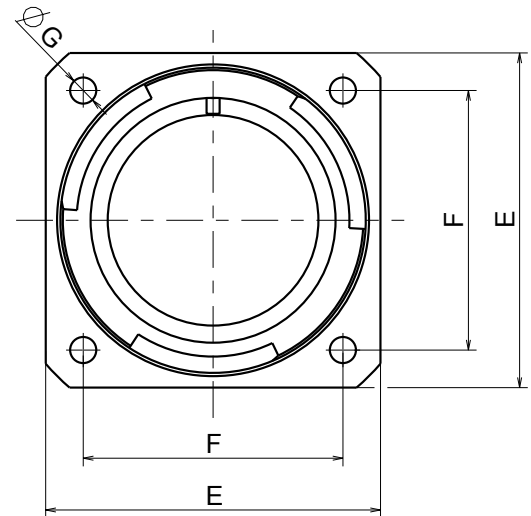
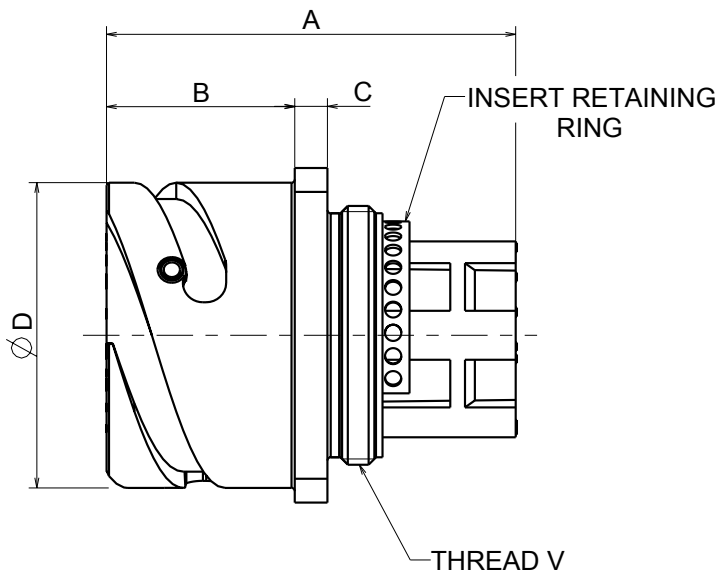

SIZE	A	B +0.4-0	C ±0.2	ØD +0-0.15	E ±0.3	F ±0.1	ØG	Thread V
16S	40	18.2	3.2	27.4	32.5	24.6	3.2	7/8"-20 UNEF
18	50	23.05	4	30.8	35	27	3.2	1"-20 UNEF
20	50	23.05	4	34.2	38	29.4	3.2	1 1/8"-18 UNEF
22	50	23.05	4	37.4	41	31.8	3.2	1 1/4"-18 UNEF
24	50	23.05	4	40.9	44.5	34.9	3.7	1 3/8"-18 UNEF
28	50	24.05	4	46.7	50.8	39.7	3.7	1 5/8"-18 UNEF
32	50	24.05	4	53.4	57	44.5	4.3	1 7/8"-16 UN
36	50	24.05	4	59.6	63.5	49.2	4.3	2 1/16"-16 UN
40	50	24.05	4	65.5	69.9	55.5	4.3	2 5/16"-16 UN

Dimensions shown in mm  
Specifications and dimensions subject to change

# VBN RECEPTACLE

## VBN3--

Rear panel mounting receptacle with threaded fixing holes and a threaded rear end.

Supplied without accessories

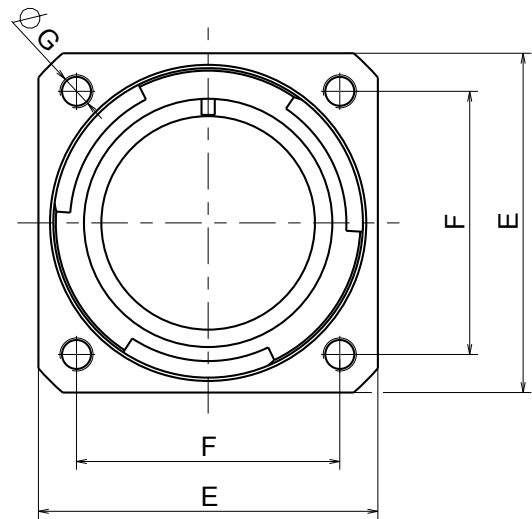
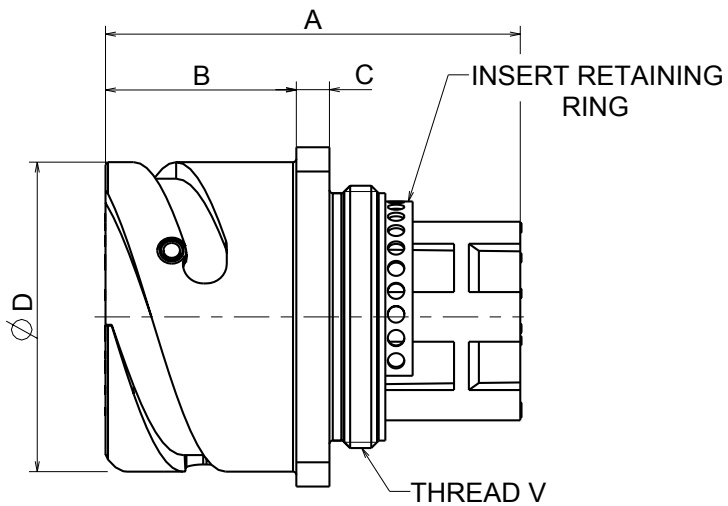

SIZE	A	B +0.4-0	C ±0.2	ØD +0-0.15	E ±0.3	F ±0.1	ØG	Thread V
16S	40	+0.4-0	3.2	27.4	32.5	24.6	M4	7/8"-20 UNEF
18	50	23.05	4	30.8	35	27	M4	1"-20 UNEF
20	50	23.05	4	34.2	38	29.4	M4	1 1/8"-18 UNEF
22	50	23.05	4	37.4	41	31.8	M4	1 1/4"-18 UNEF
24	50	23.05	4	40.9	44.5	34.9	M4	1 3/8"-18 UNEF
28	50	24.05	4	46.7	50.8	39.7	M5	1 5/8"-18 UNEF
32	50	24.05	4	53.4	57	44.5	M5	1 7/8"-16 UN
36	50	24.05	4	59.6	63.5	49.2	M5	2 1/16"-16 UN
40	50	24.05	4	65.5	69.9	55.5	M5	2 5/16"-16 UN

Dimensions shown in mm  
Specifications and dimensions subject to change

# VBN RECEPTACLE



## VBN3AV-- VBN3RV--

Rear panel mounting receptacle with threaded fixing holes.

Foresees a short straight backshell with UNEF external thread.

Supplied with (RV) or without (AV) grommet.

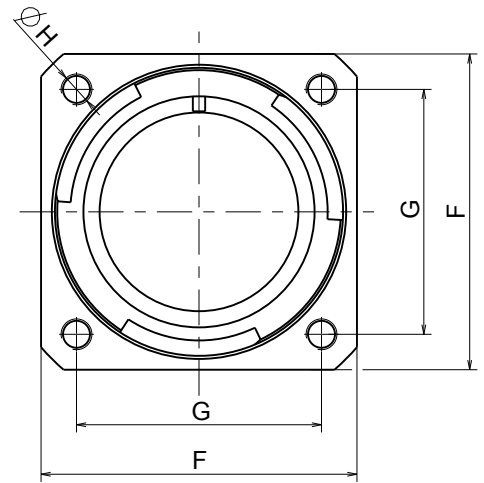
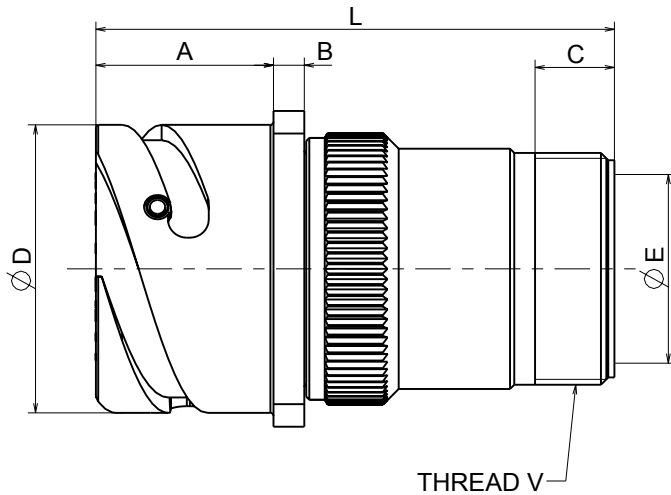

SIZE	L	A +0.4-0	B ±0.2	C Min.	ØD +0-0.15	ØE Max.	F ±0.3	G ±0.1	ØH	Thread V
16S	55	18.2	3.2	10	27.4	16.2	32.5	24.6	M4	7/8"-20 UNEF
18	65	23.05	4	10	30.8	19	35	27	M4	1"-20 UNEF
20	70	23.05	4	10	34.2	22	38	29.4	M4	1 3/16"-18 UNEF
22	70	23.05	4	10	37.4	24.5	41	31.8	M4	1 3/16"-18 UNEF
24	70	23.05	4	10	40.9	27.8	44.5	34.9	M4	1 7/16"-18 UNEF
28	75	24.05	4	10	46.7	31.2	50.8	39.7	M5	1 7/16"-18 UNEF
32	75	24.05	4	12	53.4	37.8	57	44.5	M5	1 3/4"-18 UNS
36	80	24.05	4	12	59.6	45	63.5	49.2	M5	2"-18 UNS
40	80	24.05	4	12	65.5	51.2	69.9	55.5	M5	2 1/4"-16 UN

Dimensions shown in mm  
Specifications and dimensions subject to change

# VBN RECEPTACLE

## VBN3A-- VBN3R--

Rear panel mounting receptacle with threaded fixing holes.

Foresees a standard straight backshell with UNEF external thread.

Supplied with (R) or without (A) grommet.

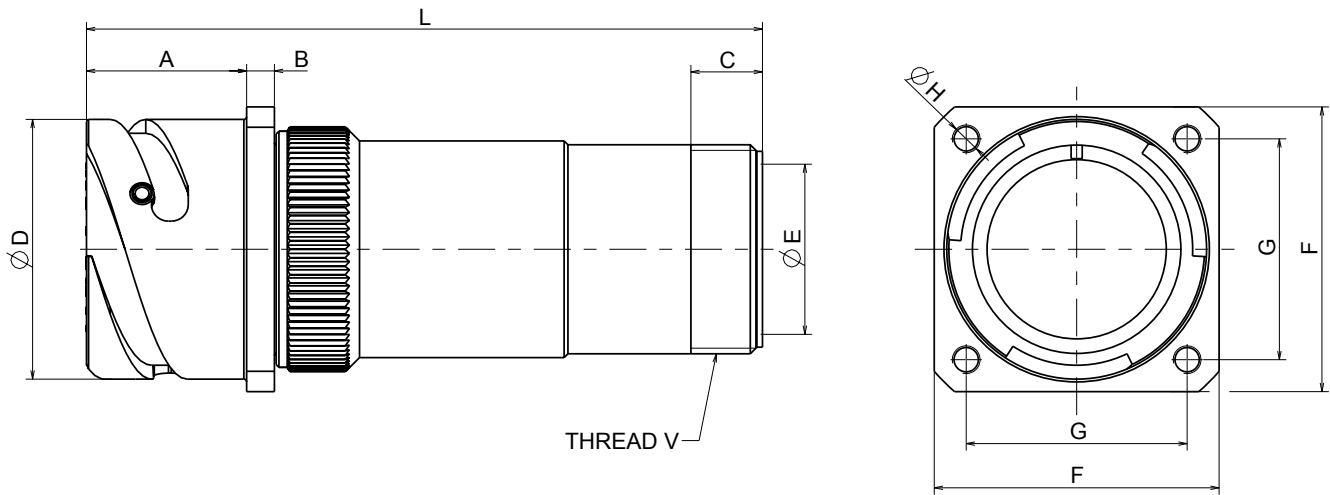

SIZE	L	A +0.4-0	B ±0.2	C Min.	ØD +0-0.15	ØE Max.	F ±0.3	G ±0.1	ØH	Thread V
16S	80	18.2	3.2	10	27.4	16.2	32.5	24.6	M4	7/8"-20 UNEF
18	100	23.05	4	10	30.8	19	35	27	M4	1"-20 UNEF
20	100	23.05	4	10	34.2	22	38	29.4	M4	1 3/16"-18 UNEF
22	100	23.05	4	10	37.4	24.5	41	31.8	M4	1 3/16"-18 UNEF
24	105	23.05	4	10	40.9	27.8	44.5	34.9	M4	1 7/16"-18 UNEF
28	105	24.05	4	10	46.7	31.2	50.8	39.7	M5	1 7/16"-18 UNEF
32	115	24.05	4	12	53.4	37.8	57	44.5	M5	1 3/4"-18 UNS
36	125	24.05	4	12	59.6	45	63.5	49.2	M5	2 "-18 UNS
40	125	24.05	4	12	65.5	51.2	69.9	55.5	M5	2 1/4"-16 UN

Dimensions shown in mm  
Specifications and dimensions subject to change

# VBN RECEPTACLE



## VBN3AM-- VBN3RM--

Rear panel mounting receptacle with threaded fixing holes.

Foresees a standard straight backshell with metric internal thread.

Supplied with (RM) or without (AM) grommet.

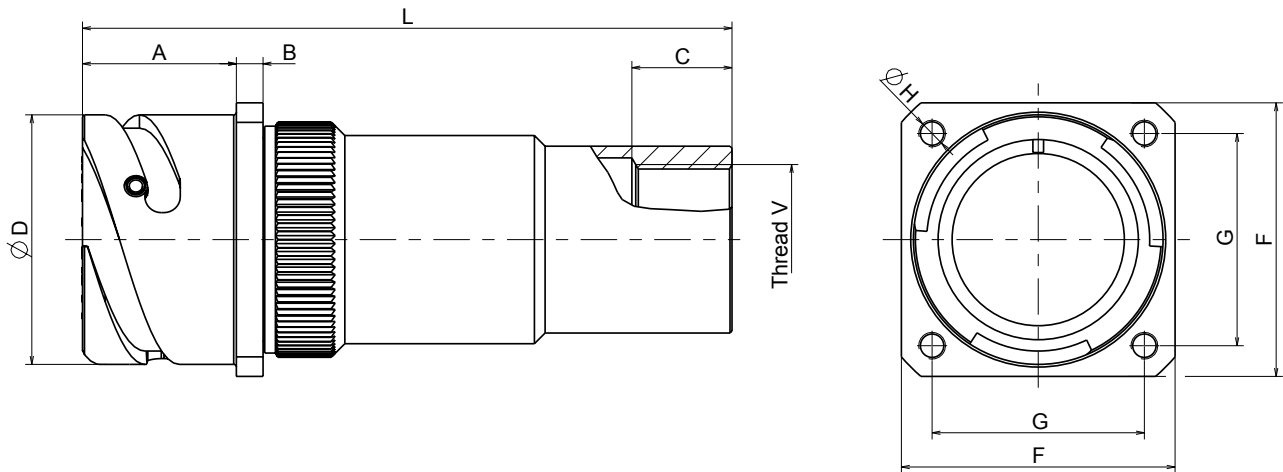

SIZE	L	A +0.4-0	B ±0.2	ØD +0-0.15	F ±0.3	G ±0.1	ØH	Thread V	
								C Min	Metric
16S	80	18.2	3.2	27.4	32.5	24.6	M4	12	M12x1.5
								15	M16x1.5
									M20x1.5
18	100	23.05	4	30.8	35	27	M4	15	M16x1.5
									M20x1.5
									M25x1.5
20	100	23.05	4	34.2	38	29.4	M4	15	M16x1.5
									M20x1.5
									M25x1.5
22	100	23.05	4	37.4	41	31.8	M4	15	M20x1.5
									M25x1.5
									M32x1.5
24	105	23.05	4	40.9	44.5	34.9	M4	15	M25x1.5
									M32x1.5
									M20x1.5
28	105	24.05	4	46.7	50.8	39.7	M5	15	M25x1.5
									M32x1.5
									M40x1.5
32	115	24.05	4	53.4	57	44.5	M5	20	M25x1.5
									M32x1.5
									M40x1.5
36	125	24.05	4	59.6	63.5	49.2	M5	20	M32x1.5
									M40x1.5
									M50x1.5
40	125	24.05	4	65.5	69.9	55.5	M5	20	M25x1.5
									M32x1.5
									M40x1.5
									M50x1.5
									M63x1.5

For additional thread size please consult the factory.

Dimensions shown in mm  
Specifications and dimensions subject to change

# VBN RECEPTACLE

## VBN3APG-- VBN3RPG--

Rear panel mounting receptacle with threaded fixing holes.

Foresees a standard straight backshell with PG internal thread.

Supplied with (RPG) or without (APG) grommet.

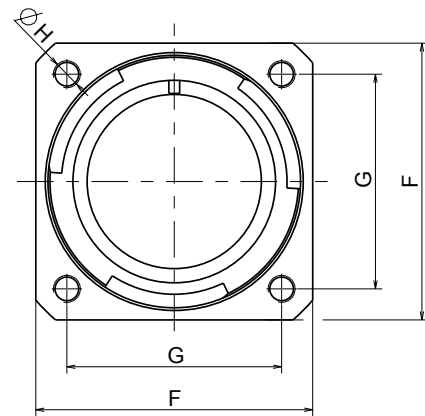
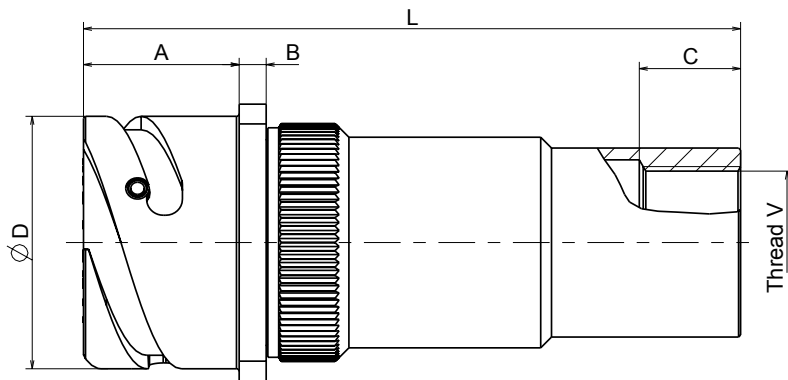

SIZE	L	A +0.4-0	B ±0.2	ØD +0-0.15	F ±0.3	G ±0.1	ØH	Thread V	
								C Min	C Min
16S	80	18.2	3.2	27.4	32.5	24.6	M4	13	PG9
18	100	23.05	4	30.8	35	27	M4	15	PG16
									PG21
20	100	23.05	4	34.2	38	29.4	M4	15	PG16
									PG29
22	100	23.05	4	37.4	41	31.8	M4	15	PG16
									PG29
24	105	23.05	4	40.9	44.5	34.9	M4	15	PG21
									PG29
								20	PG36
28	105	24.05	4	46.7	50.8	39.7	M5	15	PG21
									PG29
32	115	24.05	4	53.4	57	44.5	M5	20	PG29
									PG36
36	125	24.05	4	59.6	63.5	49.2	M5	20	PG36
									PG42
40	125	24.05	4	65.5	69.9	55.5	M5	20	PG36
									PG42

For additional thread size please consult the factory.

Dimensions shown in mm  
Specifications and dimensions subject to change

# VBN RECEPTACLE



## VBN3AF-- VBN3F--

Rear panel mounting receptacle with threaded fixing holes.

Foresees a standard straight backshell and a cable clamp with bushing for single wires.

Supplied with (F) or without (AF) grommet.

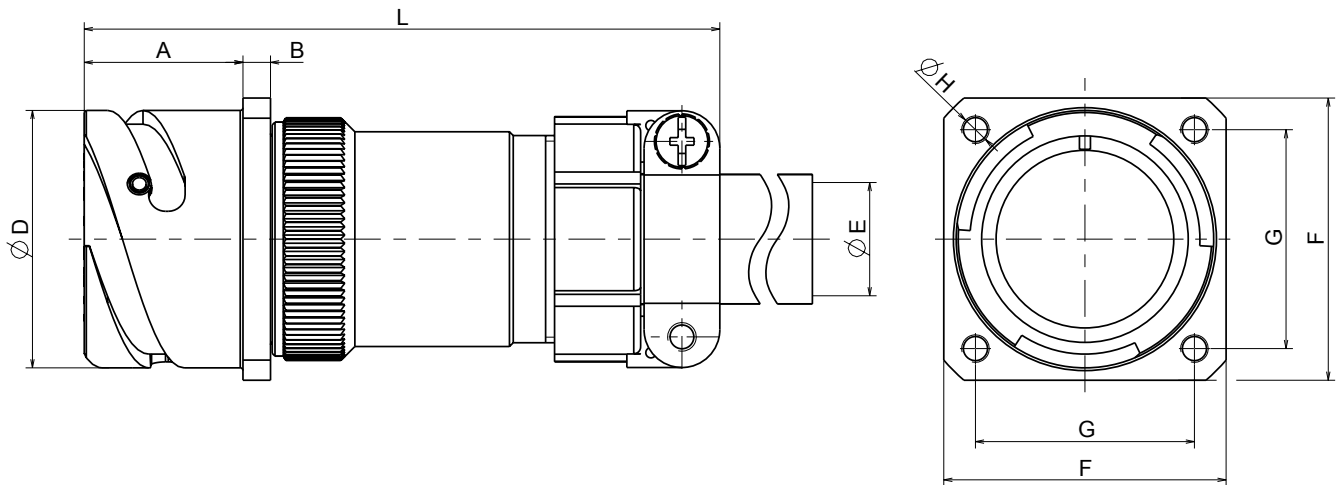

SIZE	L	A +0.4-0	B ±0.2	ØD +0-0.15	ØE (*) Max.	F ±0.3	G ±0.1	ØH
16S	105	18.2	3.2	27.4	11	32.5	24.6	M4
18	125	23.05	4	30.8	14.2	35	27	M4
20	125	23.05	4	34.2	15.8	38	29.4	M4
22	125	23.05	4	37.4	15.8	41	31.8	M4
24	130	23.05	4	40.9	19	44.5	34.9	M4
28	130	24.05	4	46.7	19	50.8	39.7	M5
32	145	24.05	4	53.4	23.8	57	44.5	M5
36	155	24.05	4	59.6	31.7	63.5	49.2	M5
40	167	24.05	4	65.5	34.9	69.9	55.5	M5

(\*): Maximum cable (or wires bundle dimension) outer diameter

Dimensions shown in mm  
Specifications and dimensions subject to change

# VBN RECEPTACLE

## VBN3CF-- VBN3CFZ--

Rear panel mounting receptacle with threaded fixing holes.

Foresees a standard straight backshell and a cable clamp for jacketed cable.

Supplied with (CFZ) or without (CF) grommet.

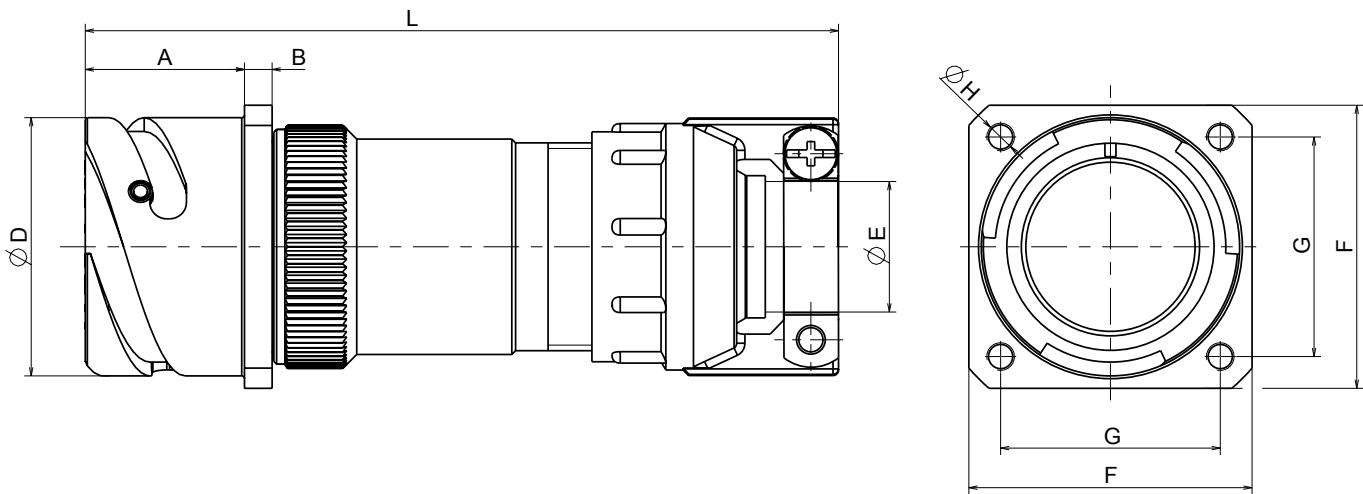

SIZE	L	A +0.4-0	B ±0.2	ØD +0-0.15	ØE (*)		F ±0.3	G ±0.1	ØH
					Min	Max			
16S	110	18.2	3.2	27.4	8	13.5	32.5	24.6	M4
18	135	23.05	4	30.8	9.6	15.8	35	27	M4
20	135	23.05	4	34.2	11.3	19	38	29.4	M4
22	135	23.05	4	37.4	11.3	19	41	31.8	M4
24	140	23.05	4	40.9	15.5	23.8	44.5	34.9	M4
28	140	24.05	4	46.7	15.5	23.8	50.8	39.7	M5
32	160	24.05	4	53.4	23.4	31.7	57	44.5	M5
36	175	24.05	4	59.6	23.4	35	63.5	49.2	M5
40	175	24.05	4	65.5	29.9	41.2	69.9	55.5	M5

(\*): cable outer diameter range.

Dimensions shown in mm  
Specifications and dimensions subject to change

# VBN RECEPTACLE



## VBN38A-- VBN38R--

Rear panel mounting receptacle with threaded fixing holes.

Foresees a 90° backshell with UNEF external thread.

Supplied with (R) or without (A) grommet.

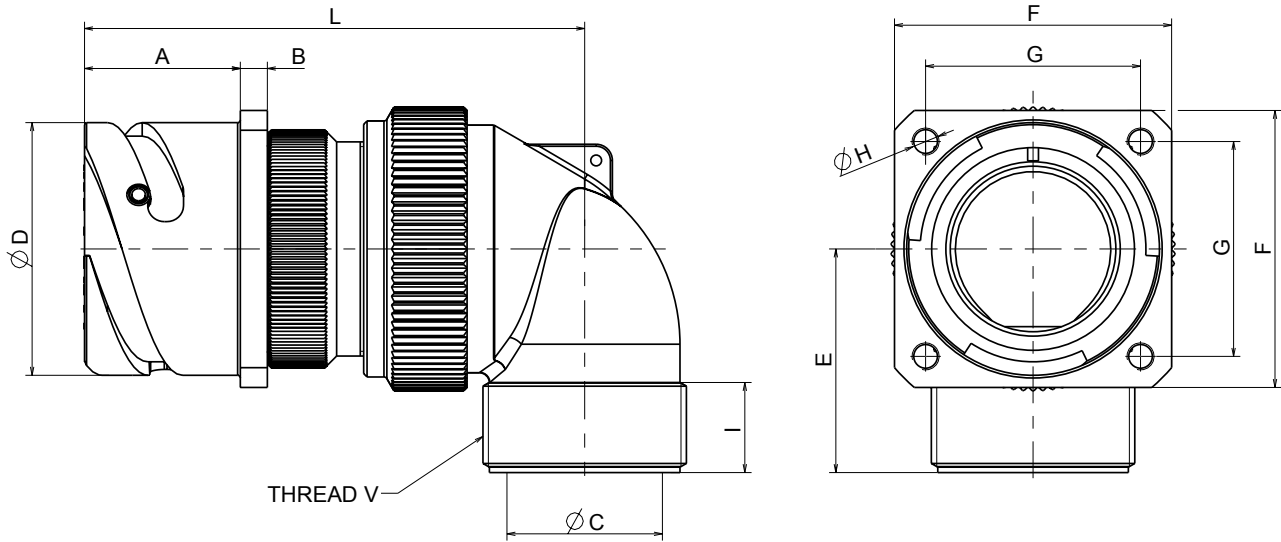

SIZE	L	A +0.4-0	B ±0.2	ØC.	ØD +0-0.15	E	F ±0.3	G ±0.1	ØH	I Min.	Thread V
16S	63	18.2	3.2	14.7	27.4	30	32.5	24.6	M4	10	7/8"-20 UNEF
18	75	23.05	4	17.2	30.8	35	35	27	M4	10	1"-20 UNEF
20	80	23.05	4	20.35	34.2	35	38	29.4	M4	10	1 3/16"-18 UNEF
22	80	23.05	4	23	37.4	35	41	31.8	M4	10	1 3/16"-18 UNEF
24	80	23.05	4	25.8	40.9	40	44.5	34.9	M4	10	1 7/16"-18 UNEF
28	80	24.05	4	28.7	46.7	40	50.8	39.7	M5	10	1 7/16"-18 UNEF
32	85	24.05	4	36.5	53.4	45	57	44.5	M5	12	1 3/4"-18 UNS
36	90	24.05	4	42.6	59.6	50	63.5	49.2	M5	12	2"-18 UNS
40	95	24.05	4	48.6	65.5	55	69.9	55.5	M5	12	2 1/4"-16 UN

The connectors are supplied with an adapter between the flange and the elbow.

Dimensions shown in mm  
Specifications and dimensions subject to change

# VBN RECEPTACLE

## VBN38AM-- VBN38RM--

Rear panel mounting receptacle with threaded fixing holes.

Foresees a 90° backshell with an adapter with metric internal thread.

Supplied with (RM) or without (AM) grommet.

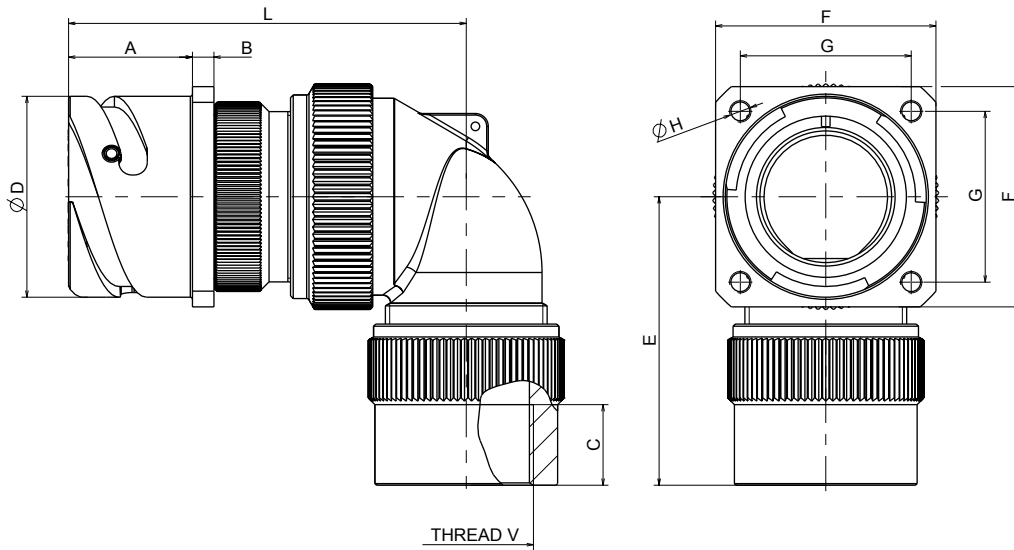

SIZE	L	A +0.4-0	B ±0.2	ØD +0-0.15	E	F ±0.3	G ±0.1	ØH	Thread V	
									C Min	Metric
16S	63	18.2	3.2	27.4	52	32.5	24.6	M4	12	M12x1.5
									15	M16x1.5 M20x1.5
18	75	23.05	4	30.8	57	35	27	M4	15	M16x1.5 M20x1.5 M25x1.5
									18	M20x1.5 M32x1.5
									20	M40x1.5
22	80	23.05	4	37.4	57	41	31.8	M4	15	M20x1.5 M25x1.5 M32x1.5
									18	M25x1.5 M32x1.5
									20	M40x1.5
24	80	23.05	4	40.9	65	44.5	34.9	M4	15	M25x1.5 M32x1.5
									18	M32x1.5 M40x1.5
									20	M40x1.5
28	80	24.05	4	46.7	65	50.8	39.7	M5	15	M25x1.5 M32x1.5
									18	M32x1.5 M40x1.5
									20	M40x1.5
32	85	24.05	4	53.4	70	57	44.5	M5	20	M25x1.5 M32x1.5 M40x1.5
									18	M32x1.5 M40x1.5
									20	M40x1.5
36	90	24.05	4	59.6	78	63.5	49.2	M5	20	M32x1.5 M40x1.5 M50x1.5
									18	M40x1.5 M50x1.5
									20	M50x1.5
40	95	24.05	4	65.5	80	69.9	55.5	M5	20	M40x1.5 M50x1.5 M63x1.5
									18	M50x1.5
									20	M63x1.5

The connectors are supplied with an adapter between the flange and the elbow.

Dimensions shown in mm  
Specifications and dimensions subject to change

# VBN RECEPTACLE



## VBN38APG-- VBN38RPG--

Rear panel mounting receptacle with threaded fixing holes.

Foresees a 90° backshell with an adapter with PG internal thread.

Supplied with (RPG) or without (APG) grommet.

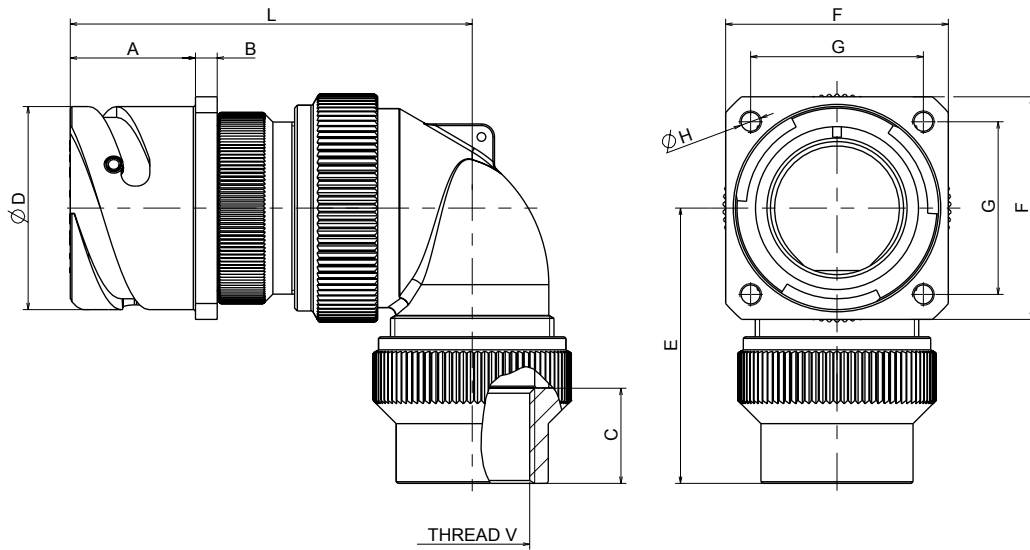

SIZE	L	A +0.4-0	B ±0.2	ØD +0-0.15	F ±0.3	E	G ±0.1	ØH	Thread V	
									C Min	PG
16S	63	18.2	3.2	27.4	32.5	48	24.6	M4	14	PG9
18	75	23.05	4	30.8	35	54	27	M4	14	PG16
										PG21
20	80	23.05	4	34.2	38	53	29.4	M4	15	PG16
									13	PG29
22	80	23.05	4	37.4	41	53	31.8	M4	15	PG16
									13	PG29
24	80	23.05	4	40.9	44.5	58	34.9	M4	13	PG21
						69			15	PG36
						58			13	PG21
28	80	24.05	4	46.7	50.8	58	39.7	M5	13	PG21
						69			15	PG36
						60			15	PG29
32	85	24.05	4	53.4	57	71	44.5	M5	15	PG36
						60			15	PG29
36	90	24.05	4	59.6	63.5	68	49.2	M5	15	PG36
									74	15
40	95	24.05	4	65.5	69.9	76	55.5	M5	15	PG42
						74			15	PG48

The connectors are supplied with an adapter between the flange and the elbow. For additional thread size please consult the factory.

Dimensions shown in mm  
Specifications and dimensions subject to change

# VBN RECEPTACLE

## VBN38AF-- VBN38F--

Rear panel mounting receptacle with threaded fixing holes.

Foresees a 90° backshell and a cable clamp with bushing for single wires.

Supplied with (F) or without (AF) grommet.

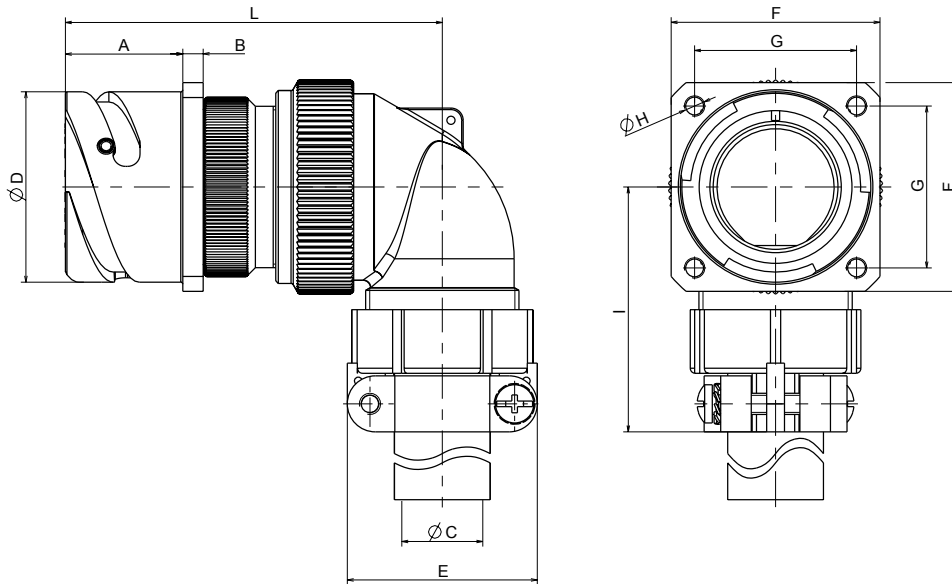

SIZE	L	A +0.4-0	B ±0.2	ØC (*) Max.	ØE +0-0.15	E Max.	F ±0.3	G ±0.1	ØH	I
16S	63	18.2	3.2	11	27.4	30	32.5	24.6	M4	45
18	75	23.05	4	14.2	30.8	32.2	35	27	M4	53
20	80	23.05	4	15.8	34.2	37.5	38	29.4	M4	53
22	80	23.05	4	15.8	37.4	37.5	41	31.8	M4	53
24	80	23.05	4	19	40.9	43.3	44.5	34.9	M4	58
28	80	24.05	4	19	46.7	43.3	50.8	39.7	M5	58
32	85	24.05	4	23.8	53.4	51.7	57	44.5	M5	66
36	90	24.05	4	31.7	59.6	58	63.5	49.2	M5	69
40	95	24.05	4	34.9	65.5	68.5	69.9	55.5	M5	95

(\*): Maximum cable (or wires bundle dimension) outer diameter. The connectors are supplied with an adapter between the flange and the elbow.

Dimensions shown in mm  
Specifications and dimensions subject to change

# VBN RECEPTACLE



## VBN38CF-- VBN38CFZ--

Rear panel mounting receptacle with threaded fixing holes.

Foresees a 90° backshell and a cable clamp for jacketed cable.

Supplied with (CFZ) or without (CF) grommet.

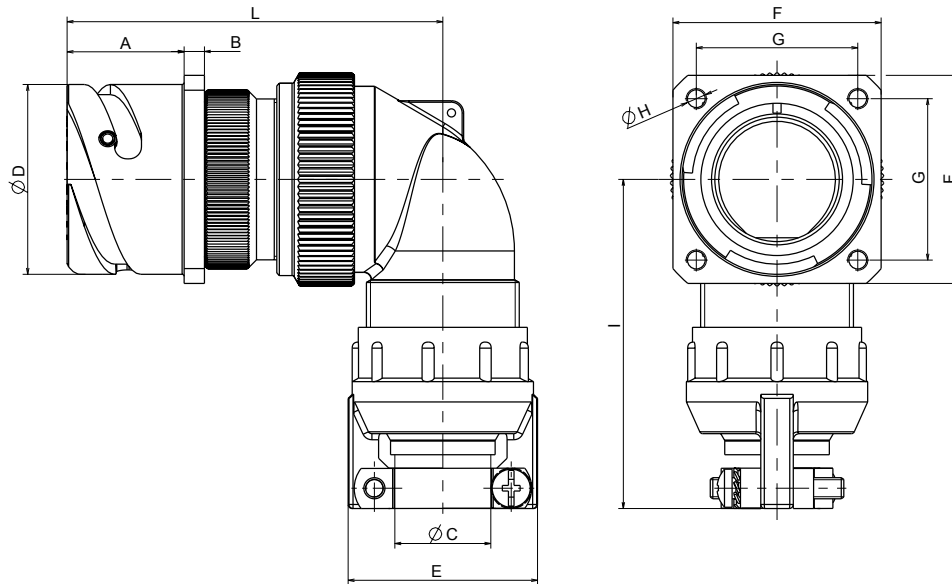

SIZE	L	A +0.4-0	B ±0.2	ØC (*)		ØD +0-0.15	E Max.	F±0.3	G ±0.1	ØH	I
				Min	Max						
16S	63	18.2	3.2	8	13.5	27.4	28.1	32.5	24.6	M4	61
18	75	23.05	4	9.6	15.8	30.8	31	35	27	M4	68
20	80	23.05	4	11.3	19	34.2	37.3	38	29.4	M4	68
22	80	23.05	4	11.3	19	37.4	37.3	41	31.8	M4	68
24	80	23.05	4	15.5	23.8	40.9	42	44.5	34.9	M4	76
28	80	24.05	4	15.5	23.8	46.7	42	50.8	39.7	M5	76
32	85	24.05	4	23.4	31.7	53.4	54	57	44.5	M5	97
36	90	24.05	4	23.4	35	59.6	57.1	63.5	49.2	M5	98
40	95	24.05	4	29.9	41.2	65.5	63.5	69.9	55.5	M5	103

(\*): cable outer diameter range. The connectors are supplied with an adapter between the flange and the elbow.

Dimensions shown in mm  
Specifications and dimensions subject to change

# VBN PLUG

## VBN6--

Plug connector with standard coupling nut.

Foresees a threaded rear end.

Supplied without accessories

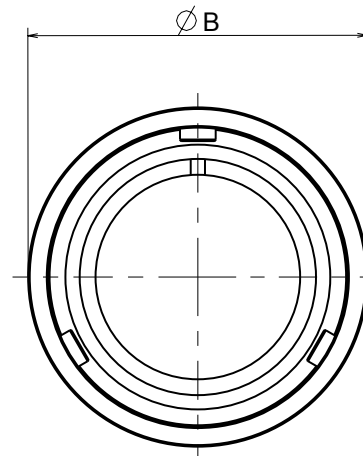
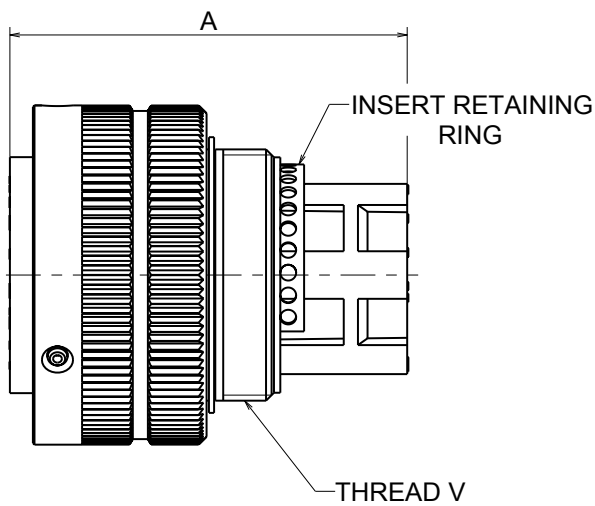

SIZE	A	ØB Max.	Thread V
16S	40	32	7/8"-20 UNEF
18	50	36.5	1"-20 UNEF
20	50	39.9	1 1/8"-18 UNEF
22	50	43.1	1 1/4"-18 UNEF
24	50	46.6	1 3/8"-18 UNEF
28	50	53.4	1 5/8"-18 UNEF
32	50	60.1	1 7/8"-16 UN
36	50	66.3	2 1/16"-16 UN
40	50	72.5	2 5/16"-16 UN

Dimensions shown in mm  
Specifications and dimensions subject to change

**MGPVBN6--**

Plug connector with rubber covered coupling nut.

Foresees a threaded rear end.

Supplied without accessories

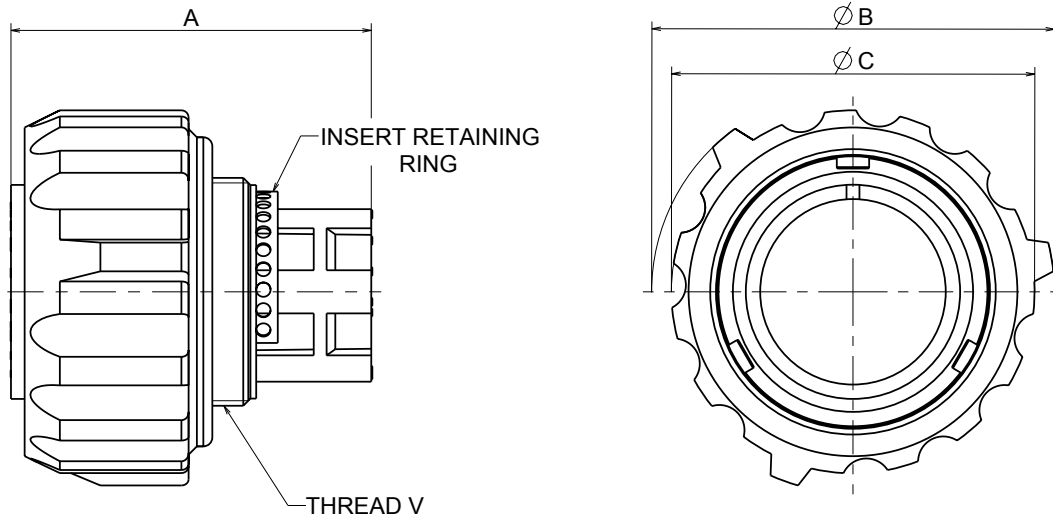

SIZE	A	ØB	ØC	Thread V
16S	40	44	38.9	7/8"-20 UNEF
18	50	49	43.5	1"-20 UNEF
20	50	51.5	46	1 1/8"-18 UNEF
22	50	56	50.5	1 1/4"-18 UNEF
24	50	60	54	1 3/8"-18 UNEF
28	50	67	61	1 5/8"-18 UNEF
32	50	76	67.6	1 7/8"-16 UN
36	50	82.3	74.3	2 1/16"-16 UN
40	50	88	80	2 5/16"-16 UN

Dimensions shown in mm  
 Specifications and dimensions subject to change

# VBN PLUG

## VBN6AV-- VBN6RV--

Plug connector with standard coupling nut.

Foresees a short straight backshell with UNEF external thread.

Supplied with (RV) or without (AV) grommet.

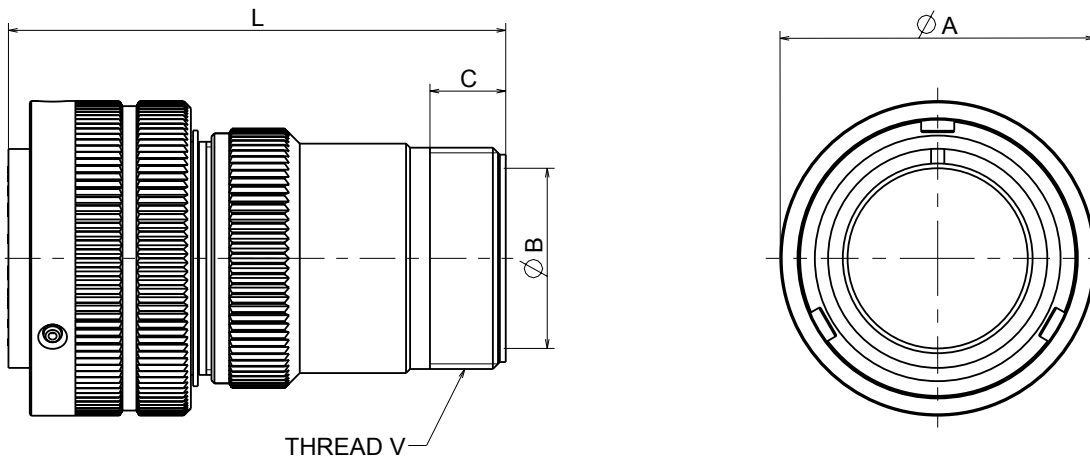

SIZE	L	ØA Max.	ØB Max.	C Min.	Thread V
16S	55	32	16.2	10	7/8"-20 UNEF
18	65	36.5	19	10	1"-20 UNEF
20	70	39.9	22	10	1 3/16"-18 UNEF
22	70	43.1	24.5	10	1 3/16"-18 UNEF
24	70	46.6	27.8	10	1 7/16"-18 UNEF
28	75	53.4	31.2	10	1 7/16"-18 UNEF
32	75	60.1	37.8	12	1 3/4"-18 UNS
36	80	66.3	45	12	2 "-18 UNS
40	80	72.5	51.2	12	2 1/4"-16 UN

Dimensions shown in mm  
Specifications and dimensions subject to change

# VBN PLUG



## VBN6A-- VBN6R--

Plug connector with standard coupling nut.

Foresees a standard straight backshell with UNEF external thread.

Supplied with (R) or without (A) grommet.

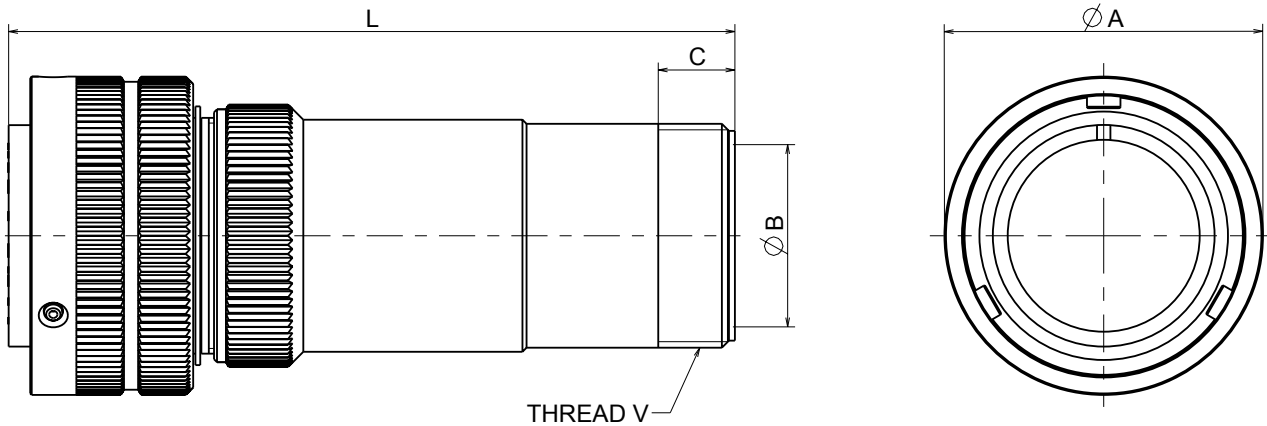

SIZE	L	ØA Max.	ØB Max.	C Min.	Thread V
16S	80	32	16.2	10	7/8"-20 UNEF
18	100	36.5	19	10	1"-20 UNEF
20	100	39.9	22	10	1 3/16"-18 UNEF
22	100	43.1	24.5	10	1 3/16"-18 UNEF
24	105	46.6	27.8	10	1 7/16"-18 UNEF
28	105	53.4	31.2	10	1 7/16"-18 UNEF
32	115	60.1	37.8	12	1 3/4"-18 UNS
36	125	66.3	45	12	2 "-18 UNS
40	125	72.5	51.2	12	2 1/4"-16 UN

Dimensions shown in mm  
Specifications and dimensions subject to change

# VBN PLUG

## VBN6AM-- VBN6RM--

Plug connector with standard coupling nut.

Foresees a standard straight backshell with metric internal thread.

Supplied with (RM) or without (AM)t grommet.

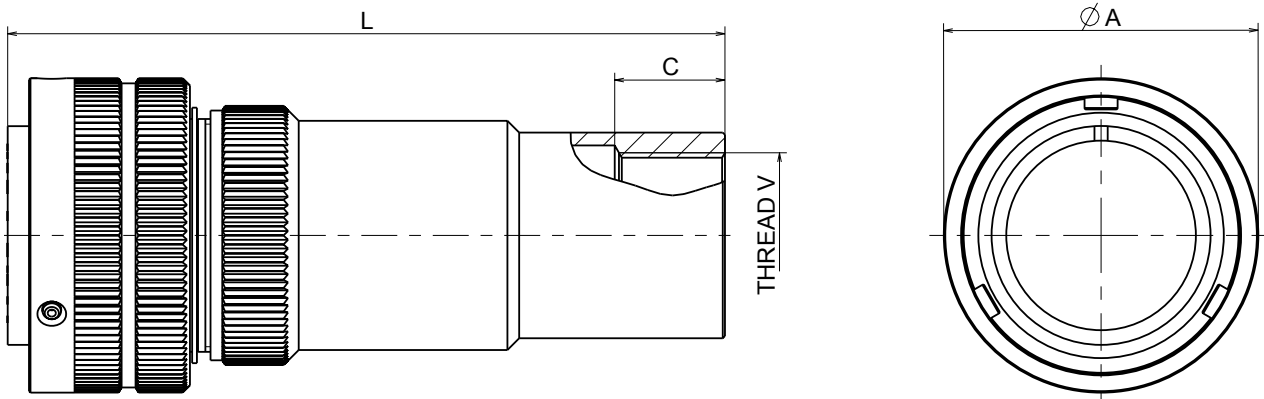

SIZE	L	ØA Max.	Thread V	
			C Min	Metric
165	80	32	12	M12x1.5
			15	M16x1.5
				M20x1.5
18	100	36.5	15	M16x1.5
				M20x1.5
				M25x1.5
20	100	39.9	18	M32x1.5
			15	M16x1.5
				M20x1.5
22	100	43.1	15	M25x1.5
				M20x1.5
				M32x1.5
24	105	46.6	15	M25x1.5
			18	M32x1.5
			18	M20x1.5
28	105	53.4	15	M25x1.5
			15	M32x1.5
			20	M40x1.5
32	115	60.1	20	M25x1.5
				M32x1.5
				M40x1.5
36	125	66.3	20	M32x1.5
				M40x1.5
				M50x1.5
40	125	72.5	20	M25x1.5
				M32x1.5
				M40x1.5
				M50x1.5
				M63x1.5

For additional thread size please consult the factory.

Dimensions shown in mm  
Specifications and dimensions subject to change

# VBN PLUG



## VBN6APG-- VBN6RPG--

Plug connector with standard coupling nut.

Foresees a standard straight backshell with PG internal thread.

Supplied with (RPG) or without (APG) grommet.

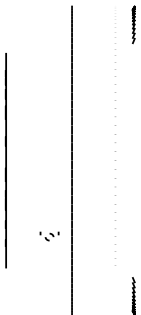

SIZE	L	ØA Max.	Thread V	
			C Min	PG
16S	80	32	13	PG9
18	100	36.5	15	PG16
			15	PG21
			15	PG16
20	100	39.9	15	PG16
			15	PG29
			15	PG16
22	100	43.1	15	PG16
			15	PG29
			15	PG21
24	105	46.6	15	PG21
			15	PG29
			20	PG36
28	105	53.4	15	PG21
			15	PG29
			20	PG36
32	115	60.1	20	PG29
			20	PG36
			20	PG36
36	125	66.3	20	PG36
			20	PG42
			20	PG36
40	125	72.5	20	PG36
			20	PG42

For additional thread size please consult the factory.

Dimensions shown in mm  
Specifications and dimensions subject to change

# VBN PLUG

## VBN6AF-- VBN6F--

Plug connector with standard coupling nut.

Foresees a standard straight backshell and a cable clamp with bushing for single wires.

Supplied with (F) or without (AF) grommet.

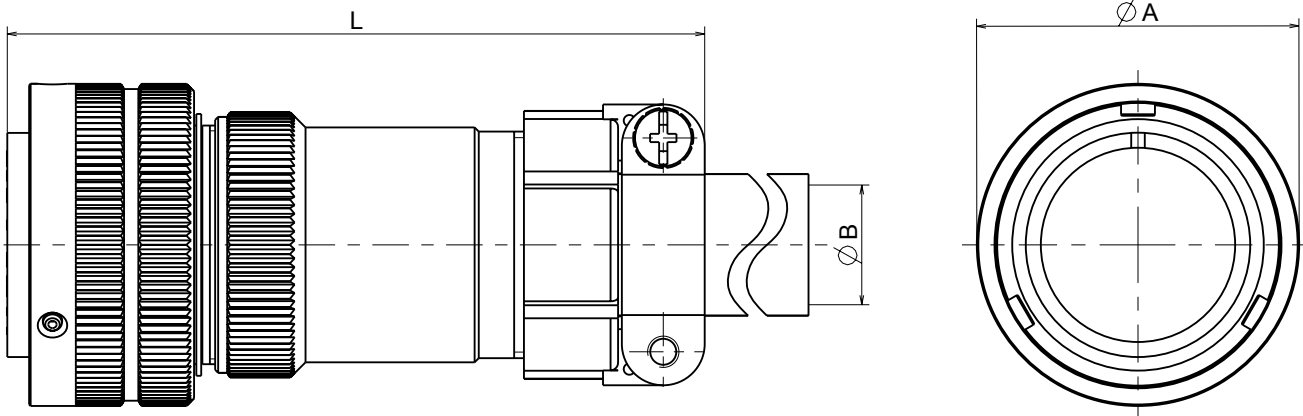

SIZE	L	ØA Max.	ØB (*) Max.
16S	105	32	11
18	125	36.5	14.2
20	125	39.9	15.8
22	125	43.1	15.8
24	130	46.6	19
28	130	53.4	19
32	145	60.1	23.8
36	155	66.3	31.7
40	167	72.5	34.9

(\*): Maximum cable (or wires bundle dimension) outer diameter The connectors are supplied with an adapter between the flange and the elbow.

Dimensions shown in mm  
Specifications and dimensions subject to change

# VBN PLUG



## VBN6CF-- VBN6CFZ--

Plug connector with standard coupling nut.

Foresees a standard straight backshell and a cable clamp for jacketed cable.

Supplied with (CFZ) or without (CF) grommet.

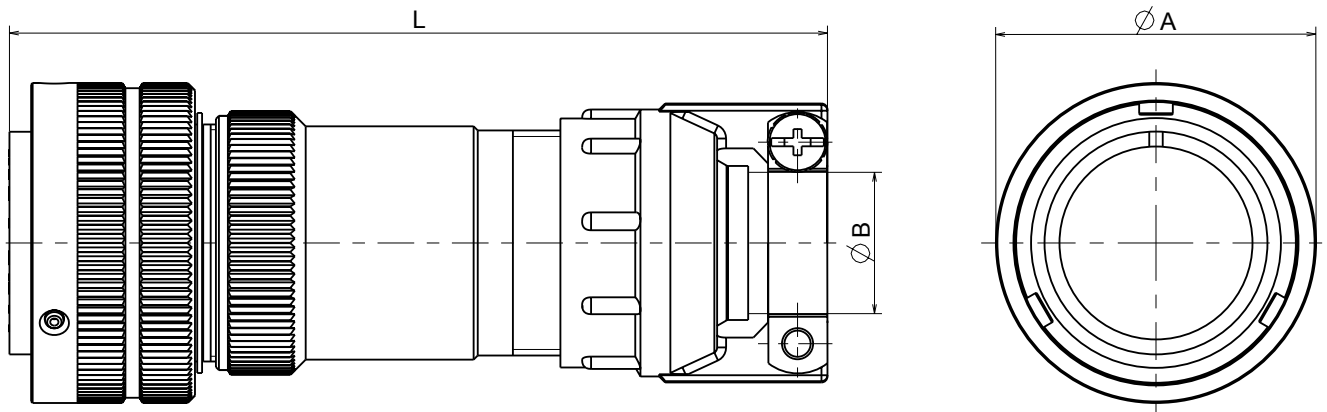

SIZE	L	ØA Max.	ØB (*)	
			Min	Max.
16S	110	32	8	13.5
18	135	36.5	9.6	15.8
20	135	39.9	11.3	19
22	135	43.1	11.3	19
24	140	46.6	15.5	23.8
28	140	53.4	15.5	23.8
32	160	60.1	23.4	31.7
36	175	66.3	23.4	35
40	175	72.5	29.9	41.2

(\*): cable outer diameter range.

Dimensions shown in mm  
Specifications and dimensions subject to change

# VBN PLUG

## VBN8A-- VBN8R--

Plug connector with standard coupling nut.

Foresees a 90° backshell with UNEF external thread.

Supplied with (R) or without (A) grommet.

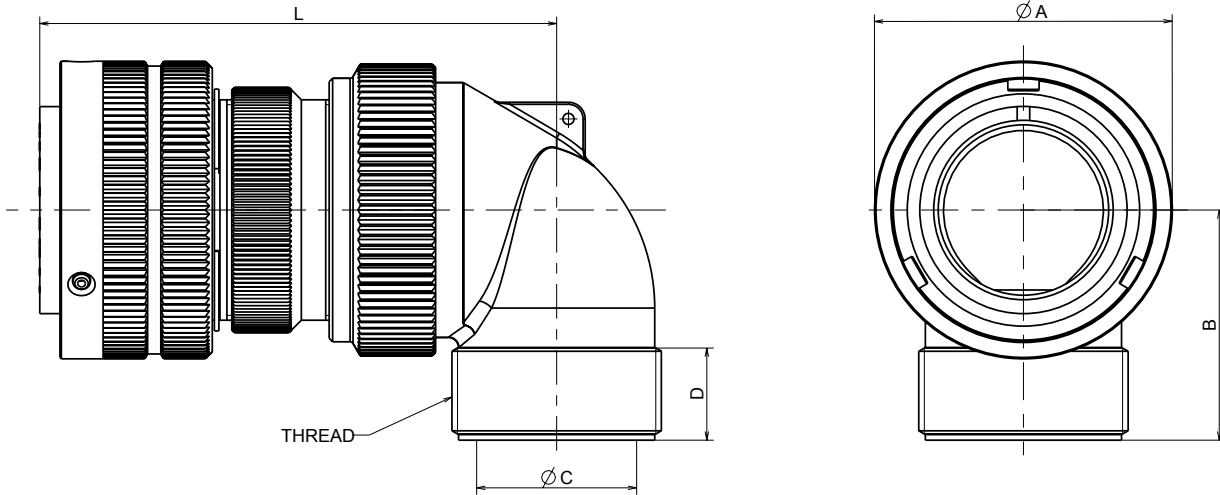

SIZE	L	ØA Max.	B	ØC Max.	D Min.	Thread V
16S	63	32	30	14.7	10	7/8"-20 UNEF
18	75	36.5	35	17.2	10	1"-20 UNEF
20	80	39.9	35	20.35	10	1 3/16"-18 UNEF
22	80	43.1	35	23	10	1 3/16"-18 UNEF
24	80	46.6	40	25.8	10	1 7/16"-18 UNEF
28	80	53.4	40	28.7	10	1 7/16"-18 UNEF
32	85	60.1	45	36.5	12	1 3/4"-18 UNS
36	90	66.3	50	42.6	12	2 "-18 UNS
40	95	72.5	55	48.6	12	2 1/4"-16 UN

The connectors are supplied with an adapter between the plugshell and the elbow.

Dimensions shown in mm  
Specifications and dimensions subject to change

# VBN PLUG



## VBN8AM-- VBN8RM--

Plug connector with standard coupling nut.

Foresees a 90° backshell with metric internal thread.

Supplied with (RM) or without (AM) grommet.

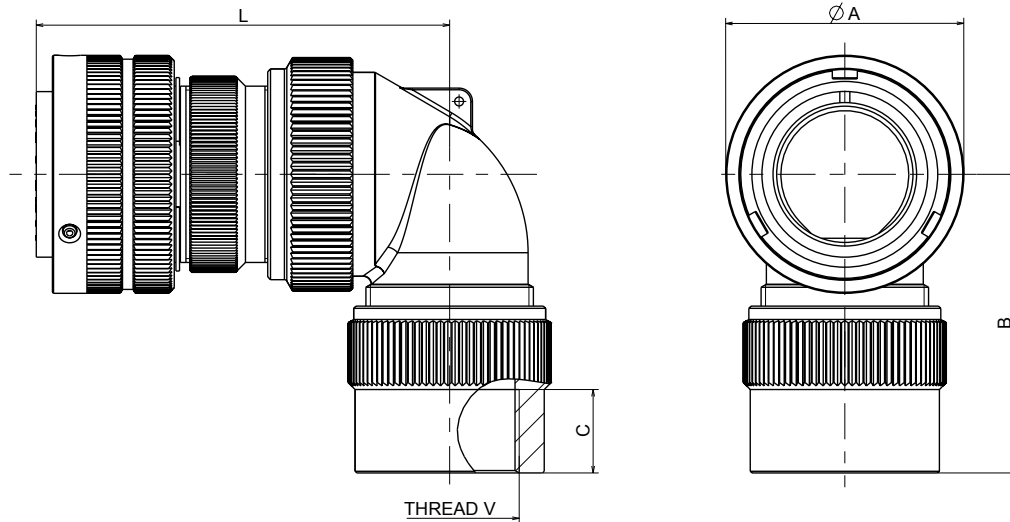

SIZE	L	ØA Max.	B	Thread V	
				Min	Max.
16S	63	32	52	12	M12x1.5
				15	M16x1.5 M20x1.5
18	75	36.5	57	15	M16x1.5 M20x1.5 M25x1.5
				15	M20x1.5 M25x1.5
20	80	39.9	57	15	M20x1.5 M25x1.5
				18	M32x1.5
22	80	43.1	57	15	M20x1.5 M25x1.5
				18	M32x1.5
24	80	46.6	65	15	M25x1.5
				18	M32x1.5
				20	M40x1.5
28	80	53.4	65	15	M25x1.5
				18	M32x1.5
				20	M40x1.5
32	85	60.1	70	20	M25x1.5 M32x1.5 M40x1.5
				20	M32x1.5 M40x1.5
36	90	66.3	78	20	M32x1.5 M40x1.5 M50x1.5
				20	M40x1.5 M50x1.5
				20	M50x1.5 M63x1.5

The connectors are supplied with an adapter between the plugshell and the elbow. For additional thread size please consult the factory.

Dimensions shown in mm  
Specifications and dimensions subject to change

# VBN PLUG

## VBN8APG-- VBN8RPG--

Plug connector with standard coupling nut.

Foresees a 90° backshell with PG internal thread.

Supplied with (RPG) or without (APG) grommet.

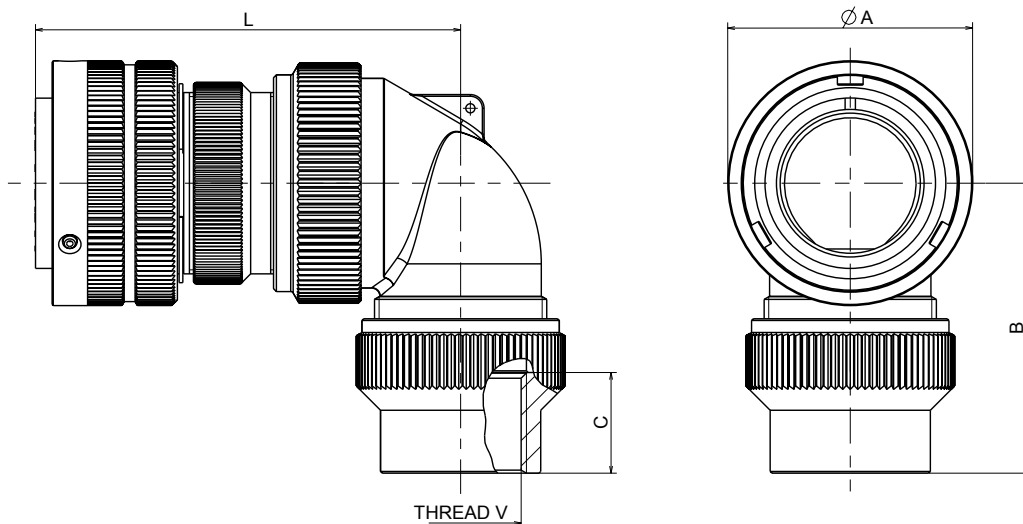

SIZE	L	ØA Max.	B	Thread V	
				C Min	PG
16S	63	32	48	14	PG9
18	75	36.5	54	14	PG16
				14	PG21
20	80	39.9	53	15	PG16
				13	PG29
22	80	43.1	53	15	PG16
				13	PG29
24	80	46.6	58	13	PG21
				15	PG29
				15	PG36
28	80	53.4	58	13	PG21
				15	PG29
				15	PG36
32	85	60.1	60	15	PG29
					71
36	90	66.3	68	15	PG36
					PG42
40	95	72.5	74	15	PG42
			76		PG48

The connectors are supplied with an adapter between the plugshell and the elbow. For additional thread size please consult the factory.

Dimensions shown in mm  
Specifications and dimensions subject to change

# VBN PLUG



## VBN8AF-- VBN8F--

Plug connector with standard coupling nut.

Foresees a 90° backshell and a cable clamp with bushing for single wires.

Supplied with (F) or without (AF) grommet.

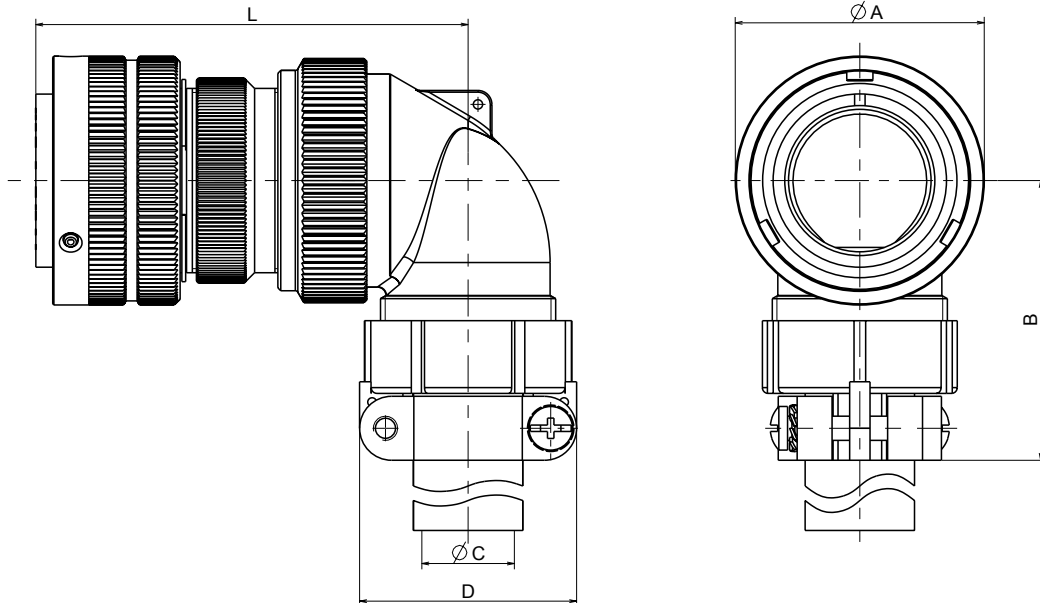

SIZE	L	ØA Max.	B	ØC (*) Max.	D Max.
16S	63	32	45	11	30
18	75	36.5	53	14.2	32.2
20	80	39.9	53	15.8	37.5
22	80	43.1	53	15.8	37.5
24	80	46.6	58	19	43.3
28	80	53.4	58	19	43.3
32	85	60.1	66	23.8	51.7
36	90	66.3	69	31.7	58
40	95	72.5	95	34.9	68.5

(\*): Maximum cable (or wires bundle dimension) outer diameter. The connectors are supplied with an adapter between the plugshell and the elbow.

Dimensions shown in mm  
Specifications and dimensions subject to change

# VBN PLUG

## VBN8CF-- VBN8CFZ--

Plug connector with standard coupling nut.

Foresees a 90° backshell and a cable clamp for jacketed cable.

Supplied with (CFZ) or without (CF) grommet.

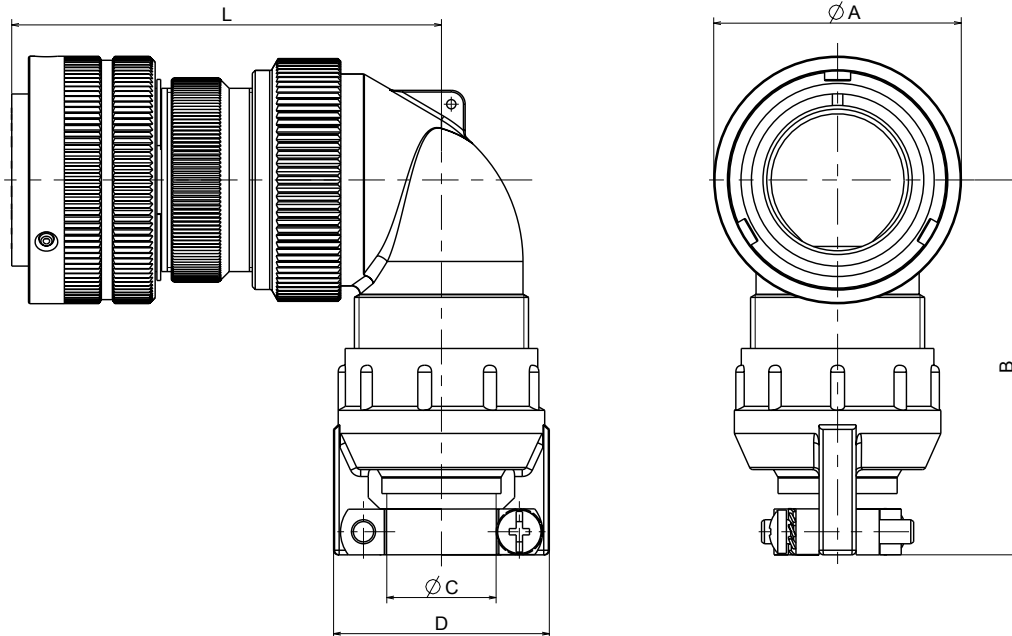

SIZE	L	ØA Max.	B	ØC (*)		D Max.
				Min	Max.	
16S	63	32	61	8	13.5	28.1
18	75	36.5	68	9.6	15.8	31
20	80	39.9	68	11.3	19	37.3
22	80	43.1	68	11.3	19	37.3
24	80	46.6	76	15.5	23.8	42
28	80	53.4	76	15.5	23.8	42
32	85	60.1	97	23.4	31.7	54
36	90	66.3	98	23.4	35	57.1
40	95	72.5	103	29.9	41.2	63.5

(\*): cable outer diameter range. The connectors are supplied with an adapter between the plugshell and the elbow.

Dimensions shown in mm  
Specifications and dimensions subject to change

## VBN SS--

Termination of shielded cables is necessary to provide RFI/EMI shielding protection. The VBN Connector series foresees a special version to connect cable shielding braid to the connector backshell and to guarantee the RFI/EMI immunity.

This version is available on both plug and receptacle, in straight and 90° version. The plugs foresees a RFI spring on the plug-shell to improve the shielding performances.

### **VBN3SS—**

Rear mounting receptacle with straight shielded backshell without grommet

### **VBN3RSS--**

Rear mounting receptacle with straight shielded backshell with grommet



### **VBN38SS—**

Rear mounting receptacle with 90° shielded backshell without grommet

### **VBN38RSS--**

Rear mounting receptacle with 90° shielded backshell with grommet



### **VBNG6SS—**

Plug with straight shielded backshell without grommet

### **VBNG6RSS--**

Plug with straight shielded backshell with grommet



### **VBNG8SS—**

Plug with 90° shielded backshell without grommet

### **VBNG8RSS--**

Plug with 90° shielded backshell with grommet



# VBN SHIELDED CONNECTORS

## VBN SS--

The connector type SS are supplied with the accessories necessary to connect the braid of the cable to the connector shells.

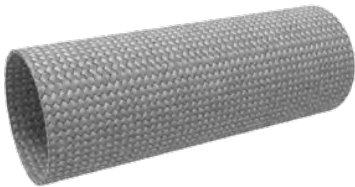

**BRAID SOCK**



**KNIT MESH**



**METALLIC TIE BAND**

The cable braid is connected to the rear knurled area of the backshell and clamped by using the metallic tie band.

If case the cable braid cannot be directly connected to the shell, it is possible to use the supplied braid sock to create a "bridge" between the cable braid and the shell; a second tie-band must be used to fix the braid sock to the cable (see below picture).



The SS system offers the possibility to connect more than one cable; in this case the braids of the cable must be wrapped together using the knit mesh to form a round shape.

The rear adapter protects the shielding area and it is available with many type of termination to guarantee sealing.

Dimensions shown in mm  
Specifications and dimensions subject to change

## VBN SS--

The connector type SS are very flexible, offering a wide range of size and termination type.

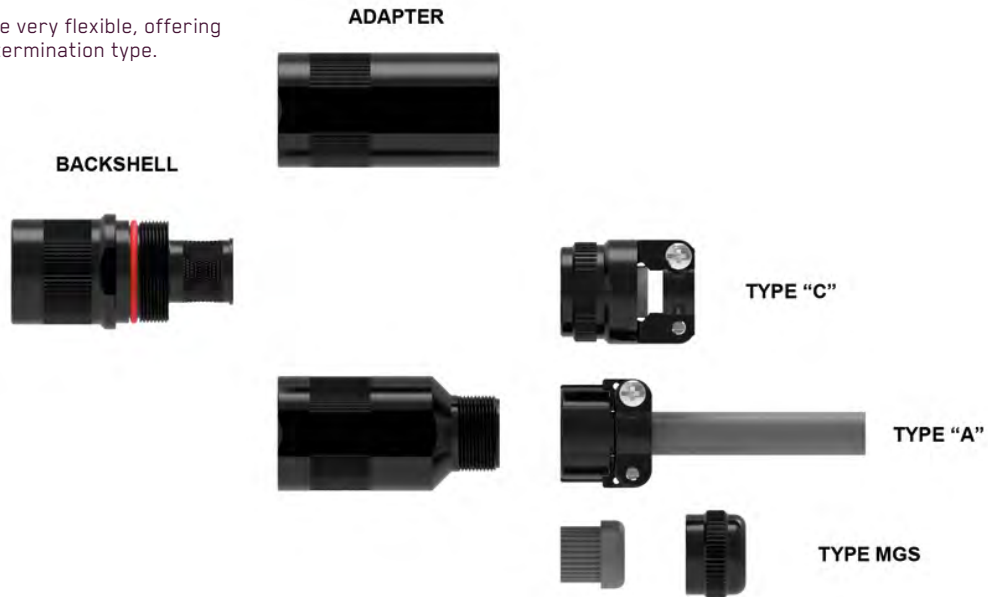

VBN CONN. SIZE	BACKSHELL		ADAPTER		CABLE CLAMP			
	Shielding System		Inner Thread		Type MGS		Type VE3057 "A" & "C"	
	SS Size	DIAM. B Max.	PG Thread	Metric Thread	Cable Clamp Size	Cable Range	Cable Clamp Size	Cable Range
16S	04	8.4	PG11 PG16	M12 M16 M20	02	5 - 8	-4	2.5 - 8
	05	13.5			03R	7 - 9	-6	6.3 - 11
	06	16.5			03	9 - 12		
18	04	8.4	PG11 PG16	M12 M16 M20	05	13 - 16	-10	9.6 - 15.8
	05	13.5			03R	7 - 9	-6	6.3 - 11
	06	16.5			04	11 - 14	-8	8 - 13.5
20	05	13.5	PG16 PG21	M16 M20 M25	05	13 - 16	-10	9.5 - 15.8
	06	16.5			04	11 - 14	-8	8 - 13.5
	05	16.5			05	13 - 16	-10	9.5 - 15.8
22	05	16.5	PG16 PG21	M16 M20 M25	06	15 - 17.5	-12	11.3 - 19
	06	19			05	13 - 16	-10	9.5 - 15.8
24	08	19	PG21 PG29	M20 M25 M32	06	15 - 17.5	-12	11.3 - 19
	10	24			07	18 - 23.5	-16	15.5 - 23.8
28	08	19	PG21 PG29 PG36	M20 M25 M32	06	15 - 17.5	-12	11.3 - 19
	10	24			07	18 - 23.5	-16	15.5 - 23.8
	12	31.2			-	-	-20	23.4 - 31.7
32	12	31.2	PG36	M32 M40	-	-	-20	23.4 - 31.7
36	13	36.5	PG42	M50	-	-	-24	23.4 - 35
	14	42	PG48	M63	-	-	-28	29.9 - 41.2
40	14	42		M63	-	-	-28	29.9 - 41.2

Dimensions shown in mm  
Specifications and dimensions subject to change



# VBN SPARE BACKSHELLS



## VBN-RV--

Short straight backshell with UNEF external thread.

Can be used on both plug and receptacle connectors, with or without grommet.

Supplied with O-Ring

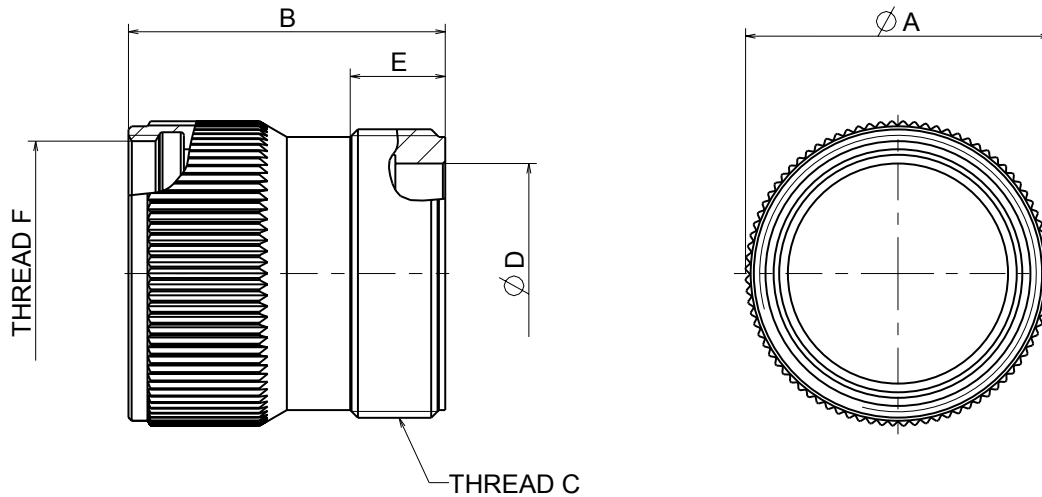

Part number	Shell size	ØA max	B ± 0.2	Thread C	Ø D ± 0.2	E Min.	Thread F
VBN-RV16STXX	16S	26	30.5	7/8"- 20 UNEF	14	9.5	7/8"- 20 UNEF
VBN-RV18TXX	18	29.5	38	1"- 20 UNEF	17	9.5	1"- 20 UNEF
VBN-RV20TXX	20	33	40	1 3/16"-18 UNEF	21	9.5	1 1/8"-18 UNEF
VBN-RV22TXX	22	36	40	1 3/16"-18 UNEF	21	9.5	1 1/4"-18 UNEF
VBN-RV24TXX	24	40	40	1 7/16"-18 UNEF	26	9.5	1 3/8"-18 UNEF
VBN-RV28TXX	28	46	45	1 7/16"-18 UNEF	26	9.5	1 5/8"-18 UNEF
VBN-RV32TXX	32	51.5	45	1 3/4"-18 UNS	32	11	1 7/8"-16 UN
VBN-RV36TXX	36	58	50	2"-18 UNS	37	11.8	2 1/16"-16 UN
VBN-RV40TXX	40	64.5	50	2 1/4"-16 UN	45	11.8	2 5/16"-16 UN

Add plating suffix to the part number

Dimensions shown in mm  
Specifications and dimensions subject to change

# VBN SPARE BACKSHELLS

## VBN-R--

Standard straight backshell with UNEF external thread.

Can be used on both plug and receptacle connectors, with or without grommet.

Supplied with O-Ring

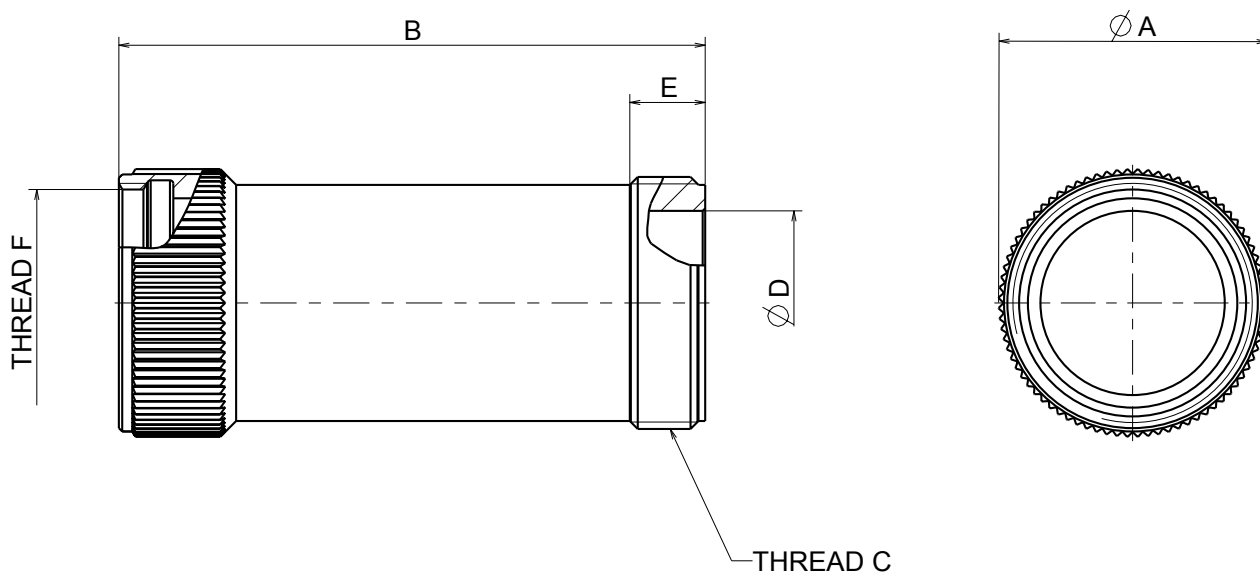

Part number	Shell size	ØA max	B ± 0.2	Thread C	Ø D ± 0.2	E Min.	Thread F
VBN-R16STXX	16S	26	55	7/8"- 20 UNEF	14	9.5	7/8"- 20 UNEF
VBN-R18TXX	18	29.5	70	1"- 20 UNEF	17	9.5	1"- 20 UNEF
VBN-R20TXX	20	33	70	1 3/16"-18 UNEF	21	9.5	1 1/8"-18 UNEF
VBN-R22TXX	22	36	70	1 3/16"-18 UNEF	21	9.5	1 1/4"-18 UNEF
VBN-R24TXX	24	40	75	1 7/16"-18 UNEF	26	9.5	1 3/8"-18 UNEF
VBN-R28TXX	28	46	75	1 7/16"-18 UNEF	26	9.5	1 5/8"-18 UNEF
VBN-R32TXX	32	51.5	85	1 3/4"-18 UNS	32	11	1 7/8"-16 UN
VBN-R36TXX	36	58	95	2"-18 UNS	37	11.8	2 1/16"-16 UN
VBN-R40TXX	40	64.5	95	2 1/4"-16 UN	45	11.8	2 5/16"-16 UN

Add plating suffix to the part number

Dimensions shown in mm  
Specifications and dimensions subject to change

# VBN SPARE BACKSHELLS



## VBN-M--

Standard straight backshell with metric internal thread.

Can be used on both plug and receptacle connectors, with or without grommet.

Supplied with O-Ring

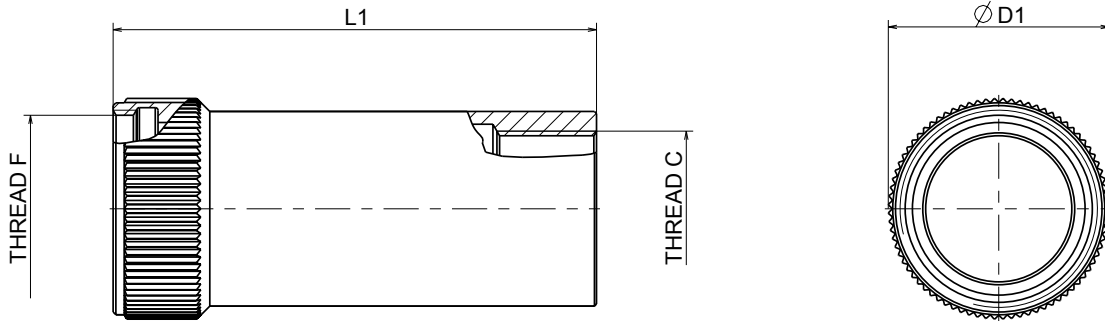

Ordering Part Number	Shell Size	D1 max	L1 ± 0,2	Thread C	Thread F
VBN-M12BL16STXX	165	28	55	M12x1.5	7/8"- 20 UNEF
VBN-M16BL16STXX	165	26	55	M16x1.5	7/8"- 20 UNEF
VBN-M20BL16STXX	165	28	55	M20x1.5	7/8"- 20 UNEF
VBN-M16BL18TXX	18	29.5	70	M16x1.5	1"- 20 UNEF
VBN-M20BL18TXX	18	29.5	70	M20x1.5	1"- 20 UNEF
VBN-M25BL18TXX	18	29.5	70	M25x1.5	1"- 20 UNEF
VBN-M32BL18TXX	18	34	70	M32x1.5	1"- 20 UNEF
VBN-M16BL20TXX	20	33	70	M16x1.5	1 1/8"-18 UNEF
VBN-M20BL20TXX	20	33	70	M20x1.5	1 1/8"-18 UNEF
VBN-M25BL20TXX	20	33	70	M25x1.5	1 1/8"-18 UNEF
VBN-M20BL22TXX	22	36	70	M20x1.5	1 1/4"-18 UNEF
VBN-M25BL22TXX	22	36	70	M25x1.5	1 1/4"-18 UNEF
VBN-M32BL22TXX	22	36	70	M32x1.5	1 1/4"-18 UNEF
VBN-M25BL24TXX	24	40	75	M25x1.5	1 3/8"-18 UNEF
VBN-M32BL24TXX	24	43	75	M32x1.5	1 3/8"-18 UNEF
VBN-M20BL28TXX	28	46	75	M20x1.5	1 5/8"-18 UNEF
VBN-M25BL28TXX	28	46	75	M25x1.5	1 5/8"-18 UNEF
VBN-M32BL28TXX	28	46	75	M32x1.5	1 5/8"-18 UNEF
VBN-M40BL28TXX	28	46	75	M40x1.5	1 5/8"-18 UNEF
VBN-M25BL32TXX	32	51.5	85	M25x1.5	1 7/8"-16 UN
VBN-M32BL32TXX	32	51.5	85	M32x1.5	1 7/8"-16 UN
VBN-M40BL32TXX	32	54	85	M40x1.5	1 7/8"-16 UN
VBN-M32BL36TXX	36	58	95	M32x1.5	2 1/16"-16 UN
VBN-M40BL36TXX	36	58	95	M40x1.5	2 1/16"-16 UN
VBN-M50BL36TXX	36	58	95	M50x1.5	2 1/16"-16 UN
VBN-M25BL40TXX	40	64.5	95	M25x1.5	2 5/16"-16 UN
VBN-M32BL40TXX	40	64.5	95	M32x1.5	2 5/16"-16 UN
VBN-M40BL40TXX	40	64.5	95	M40x1.5	2 5/16"-16 UN
VBN-M50BL40TXX	40	64.5	95	M50x1.5	2 5/16"-16 UN
VBN-M63BL40TXX	40	64.5	95	M63x1.5	2 5/16"-16 UN

For additional thread size please consult the factory. Add plating suffix to the part number

Dimensions shown in mm  
Specifications and dimensions subject to change

# VBN SPARE BACKSHELLS

## VBN-PG--

Standard straight backshell with PG internal thread.

Can be used on both plug and receptacle connectors, with or without grommet.

Supplied with O-Ring

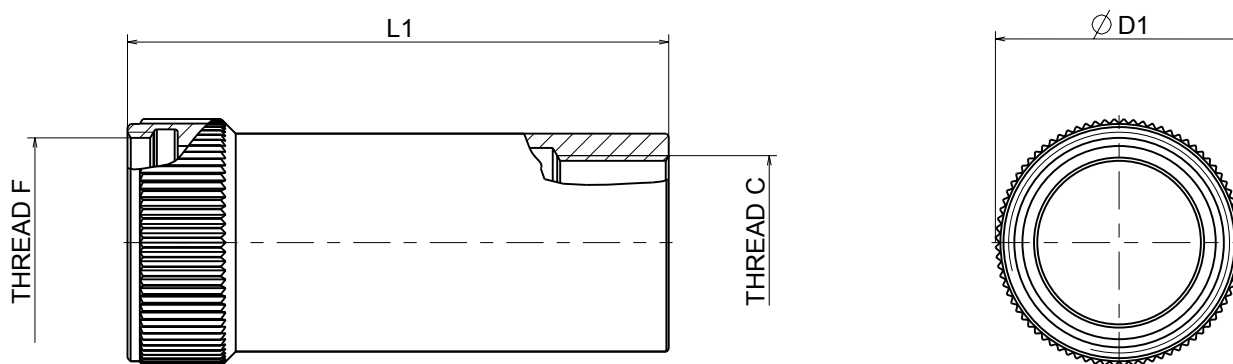

Ordering Part Number	Shell Size	D1 max	L1 ± 0,2	Thread C	Thread F
VBN-PG9BL16STXX	16S	26	55	PG9	7/8"- 20 UNEF
VBN-PG16BL18TXX	18	29.5	70	PG16	1"- 20 UNEF
VBN-PG21BL18TXX	18	34	70	PG21	1"- 20 UNEF
VBN-PG16BL20TXX	20	33	70	PG16	1 1/8"-18 UNEF
VBN-PG29BL20TXX	20	43	75	PG29	1 1/8"-18 UNEF
VBN-PG16BL22TXX	22	36	70	PG16	1 1/4"-18 UNEF
VBN-PG29BL22TXX	22	36	70	PG29	1 1/4"-18 UNEF
VBN-PG21BL24TXX	24	40	75	PG21	1 3/8"-18 UNEF
VBN-PG29BL24TXX	24	43	75	PG29	1 3/8"-18 UNEF
VBN-PG36BL24TXX	24	54	85	PG36	1 3/8"-18 UNEF
VBN-PG21BL28TXX	28	46	75	PG21	1 5/8"-18 UNEF
VBN-PG29BL28TXX	28	46	75	PG29	1 5/8"-18 UNEF
VBN-PG29BL32TXX	32	51.5	85	PG29	1 7/8"-16 UN
VBN-PG36BL32TXX	32	54	85	PG36	1 7/8"-16 UN
VBN-PG36BL36TXX	36	58	95	PG36	2 1/16"-16 UN
VBN-PG42BL36TXX	36	58	95	PG42	2 1/16"-16 UN
VBN-PG36BL40TXX	40	64.5	95	PG36	2 5/16"-16 UN
VBN-PG42BL40TXX	40	64.5	95	PG42	2 5/16"-16 UN

For additional thread size please consult the factory. Add plating suffix to the part number

Dimensions shown in mm  
Specifications and dimensions subject to change

# VBN SPARE BACKSHELLS



## VBN-90R--

Standard 90° backshell with UNEF external thread.

Can be used on both plug and receptacle connectors, with or without grommet.

Supplied with O-Ring

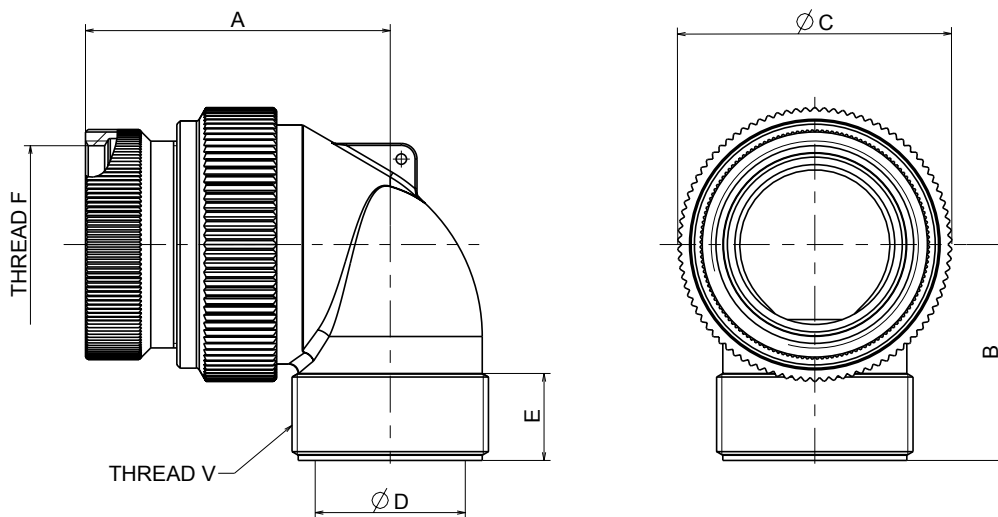

Part Number	Shell size	A	B	ØC Max.	ØD Max.	E Min.	Thread F	Thread V
VBN-90R16STXX	16S	40	30	30	14.7	10	7/8"-20 UNEF	7/8"-20 UNEF
VBN-90R18TXX	18	47	35	35	17.2	10	1"-20 UNEF	1"-20 UNEF
VBN-90R20TXX	20	53	35	37.3	20.35	10	1 1/8"-18 UNEF	1 3/16"-18 UNEF
VBN-90R22TXX	22	53	35	42	23	10	1 1/4"-18 UNEF	1 3/16"-18 UNEF
VBN-90R24TXX	24	52	40	46	25.8	10	1 3/8"-18 UNEF	1 7/16"-18 UNEF
VBN-90R28TXX	28	52	40	51	28.7	10	1 5/8"-18 UNEF	1 7/16"-18 UNEF
VBN-90R32TXX	32	56	45	58	36.5	12	1 7/8"-18 UN	1 3/4"-18 UNS
VBN-90R36TXX	36	59	50	62	42.6	12	2 1/16"-16 UN	2"-18 UNS
VBN-90R40TXX	40	65	55	69	48.6	12	2 5/16"-16 UN	2 1/4"-16 UN

The backshell is supplied with an adapter to be connected to the mating parts of the connector. Add plating suffix to the part number

Dimensions shown in mm  
Specifications and dimensions subject to change

# VBN SPARE BACKSHELLS

## VBN-MXXA--

Adapter with metric internal thread.

Can be used on the 90° backshell.

Supplied with O-Ring

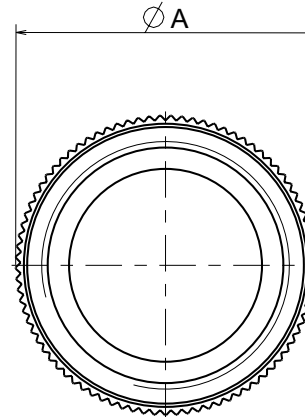
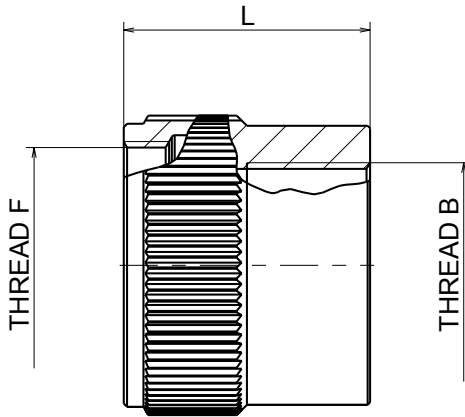

Part Number	Shell Size	ØA Max.	L	Thread B	Thread F
VBN-M12A16STXX	16S	26	27	M12x1.5	7/8"-20 UNEF
VBN-M16A16STXX				M16x1.5	
VBN-M20A16STXX				M20x1.5	
VBN-M16A18TXX	18	34	30	M16x1.5	1"-20 UNEF
VBN-M20A18TXX				M20x1.5	
VBN-M25A18TXX				M25x1.5	
VBN-M20A20TXX	20/22	36.5	27	M20x1.5	1 3/16"-18 UNEF
VBN-M25A20TXX		36.5	27	M25x1.5	
VBN-M32A20TXX		43	30	M32x1.5	
VBN-M25A24TXX	24/28	43	27	M25x1.5	1 7/16"-18 UNEF
VBN-M32A24TXX		43	27	M32x1.5	
VBN-M40A24TXX		54	38	M40x1.5	
VBN-M25A32TXX	32	50	27	M25x1.5	1 3/4"-18UNS
VBN-M32A32TXX		50	27	M32x1.5	
VBN-M40A32TXX		54	38	M40x1.5	
VBN-M32A36TXX	36	57.2	27	M32x1.5	2" -18UNS
VBN-M40A36TXX				M40x1.5	
VBN-M50A36TXX				M50x1.5	
VBN-M40A40TXX	40	65	27	M40x1.5	2 1/4"-16UN
VBN-M50A40TXX		65	27	M50x1.5	
VBN-M63A40TXX		69	31	M63x1.5	

For additional thread size please consult the factory. Add plating suffix to the part number

Dimensions shown in mm  
Specifications and dimensions subject to change

# VBN SPARE BACKSHELLS



## VBN-PGXXA--

Adapter with PG internal thread.

Can be used on the 90° backshell.

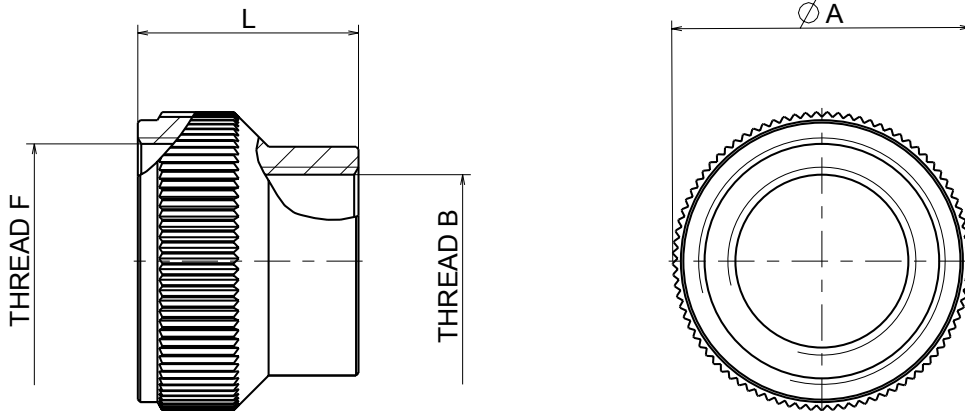

Part Number	Shell Size	ØA Max.	L	Thread B	Thread F
VBN-PG9A16STXX	16S	26	27	PG9	7/8"-20 UNEF
VBN-PG16A18TXX	18	31	28.3	PG16	1"-20 UNEF
VBN-PG21A18TXX		34	34	PG21	
VBN-PG16A20TXX	20/22	36.5	27	PG16	1 3/16"-18 UNEF
VBN-PG29A20TXX		43	27	PG29	
VBN-PG21A24TXX	24/28	43	27	PG21	1 7/16"-18 UNEF
VBN-PG29A24TXX		43	27	PG29	
VBN-PG36A24TXX		54	38	PG36	
VBN-PG29A32TXX	32	50	25.3	PG29	1 3/4"-18UNS
VBN-PG36A32TXX		54	36.3	PG36	
VBN-PG36A36TXX	36	57.2	27	PG36	2" -18UNS
VBN-PG42A36TXX				PG42	
VBN-PG42A40TXX	40	65	31	PG42	2 1/4"-16UN
VBN-PG48A40TXX		65	31	PG48	

For additional thread size please consult the factory. Add plating suffix to the part number

Dimensions shown in mm  
Specifications and dimensions subject to change

# VBN SPARE BACKSHELLS

## MGVBN-M-



Special straight backshell rubber covered and internal metric thread

It offers improved mechanical protection and electrical insulation.

Can be used on both plug and receptacle connectors, with or without grommet.

Supplied with O-Ring

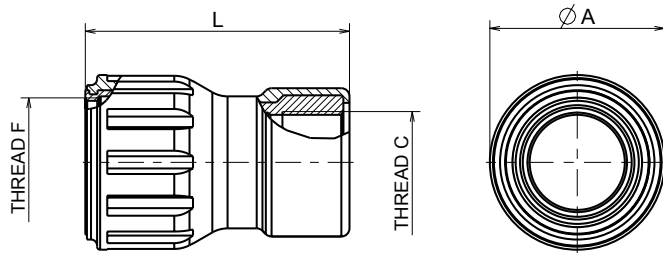

Ordering Part Number	ØA ±0.5	L ±1	Thread F	Thread C
MGVBN-M20BL18	33	65	1" – 20UNEF	M20 x 1.5
MGVBN-M25BL20	42	65	1" 1/8 – 20UNEF	M25 x 1.5
MGVBN-M25BL22	43	65	1" 1/4 - 18UNEF	M25 x 1.5
MGVBN-M32BL24	46	65	1" 3/8 – 18UNEF	M32 x 1.5
MGVBN-M32BL28	53	75	1" 5/8 – 18UNEF	M32 x 1.5
MGVBN-M32BL32	56	78	1" 7/8 – 16UN	M32 x 1.5
MGVBN-M40BL40	72	90	2" 5/16 – 16UN	M40 x 1.5

## VBN-CS1F-



These backshell offers the possibility to fix the wires bundle using tie band; it also foresees a knurled area where shielding braid or heat-shrink tube can be fixed.

Three threaded holes allows connection of ground wires.

Can be used on both plug and receptacle connectors, with or without grommet.

Supplied with O-Ring

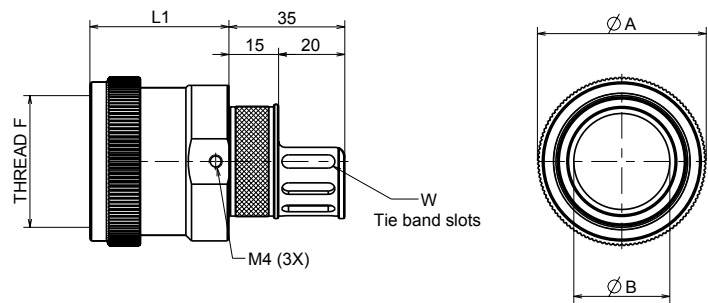

Ordering Part Number	ØA max.	ØB ±0.2	L1 ±0.3	Thread F	W slots
VBN-CS1F18TXXX	35	16.4	44.5	1" – 20UNEF	16x4 (#5)
VBN-CS1F20TXXX	37	19.3	44.5	1" 1/8 – 20UNEF	16x4 (#5)
VBN-CS1F22TXXX	42	22.0	44.5	1" 1/4 - 18UNEF	16x4 (#6)
VBN-CS1F28TXXX	51	29.0	42	1" 5/8 – 18UNEF	16x4 (#7)
VBN-CS1F32TXXX	56	34.8	43	1" 7/8 – 16UN	16x4 (#7)

Dimensions shown in mm  
Specifications and dimensions subject to change

## VBNZ--

Individual wire seal grommet.

Supplied with plastic compression ring.

The grommet foreseen stepped holes with membrane.



Shell Size	Insert layout	Male part number	Female part number	Wire O.D.
<b>16S</b>	16S-1	VBNZ16S-1P	VBNZ16S-1S	1.0/3.0
<b>18</b>	18-19	VBNZ18-19P	VBNZ18-19S	1.0/3.0
<b>20</b>	20-4	VBNZ20-4P	VBNZ20-4S	2.5/4.5
<b>20</b>	20-7	VBNZ20-7P	VBNZ20-7S	1.0/3.2
<b>20</b>	20-15	VBNZ20-15P	VBNZ20-15S	2.5/4.5
<b>22</b>	22-14	VBNZ22-14P	VBNZ22-14S	1.0/3.0
<b>22</b>	22-23	VBNZ22-23P	VBNZ22-23S	2.5/4.5
<b>24</b>	24-10	VBNZ24-10P	VBNZ24-10S	4.0/6.0
<b>28</b>	28-21	VBNZ28-21P	VBNZ28-21S	0.8/1.8
<b>28</b>	28-21	VBNZ28-21PH	VBNZ28-21SH	1.8/3
<b>32</b>	32A-13	VBNZ32A-13P	VBNZ32A-13S	2.5/4,5
<b>36</b>	36-10	VBNZ36-10P	VBNZ36-10S	0.8/1,8
<b>36</b>	36-10	VBNZ36-10PH	VBNZ36-10SH	1.8/3
<b>36</b>	36A-22	VBNZ36A-22P	VBNZ36A-22S	2.5/4.5
<b>40</b>	40A-35	VBNZ40A-35P	VBNZ40A-35S	2.5/4.5
<b>40</b>	40A-60	VBNZ40A-60P	VBNZ40A-60S	0.8/1.8
<b>40</b>	40A-60	VBNZ40A-60PH	VBNZ40A-60SH	1.8/3
<b>40</b>	40A-70	VBNZ40A-70P	VBNZ40A-70S	1.0/2.0
<b>40</b>	40A-70	VBNZ40A-70PH	VBNZ40A-70SH	2.0/3.0

### INSERT HOLE PLUG

Rubber hole plug; used to close unused cavity of the insulator and prevent dust and dirty entry.

Available for all the contact size

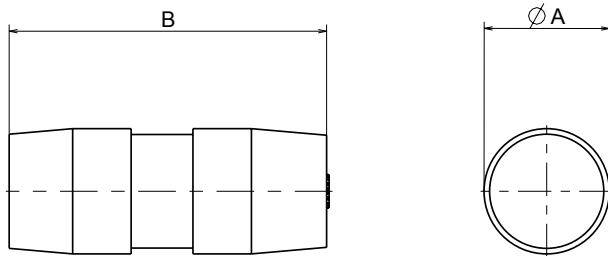

Contact size	P/N	ØA	B
16 / 16S	51605-16	3.7	13.0
12	51605-12	5.4	15.0
8	51605-8	7.5	19.0

### GROMMET HOLE PLUG

Plastic hole plug used in case the membrane of the grommet holes is pierced incorrectly or damaged.

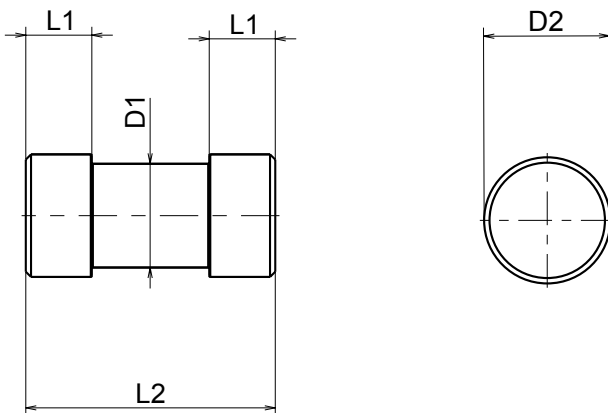
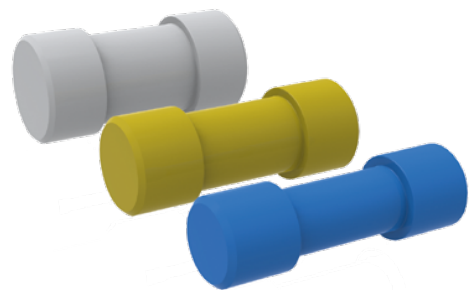

Contact size	P/N	D1	D2	L1	L2	Color
16 / 16S	VG95234 B16	2.8	3.7	3.2	11.9	Blue
12	VG95234 B12	3.7	4.6	3.2	11.9	Yellow
8	VG95234 B8	5	5.8	3.2	11.9	White

Dimensions shown in mm  
Specifications and dimensions subject to change

**VBN-PDMC- POLARIZATION PIN**

The “plastic dummy contacts” are longer than standard male contacts and can be installed in one or more contact cavities instead of standard male contacts, to completely remove the possibility of cross mating.

Cannot be used on 16S-1 arrangement.

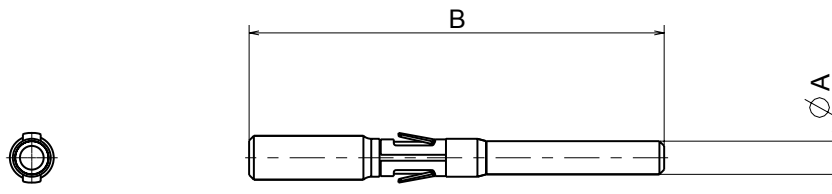

Part Number	Size	ØA	B
VBN-PDMC-16	16	2.8	35
VBN-PDMC-12	12	4.0	35

**ALIGNMENT PIN VBN-PAP-16**

For big size and high density, symmetrical contact arrangements, where very few contacts are being used, additional plastic alignment pin can guarantee a better mating of the contacts.

It is suggested to use two or more of them.

They can be installed from the front of the male insulator.

Available only for size 16 cavities.



Dimensions shown in mm  
Specifications and dimensions subject to change

**VE3057--AB**

General duty cable clamp with bushing suitable for jacketed or multi-conductor cable or wire bundles protected by shrink tubing.

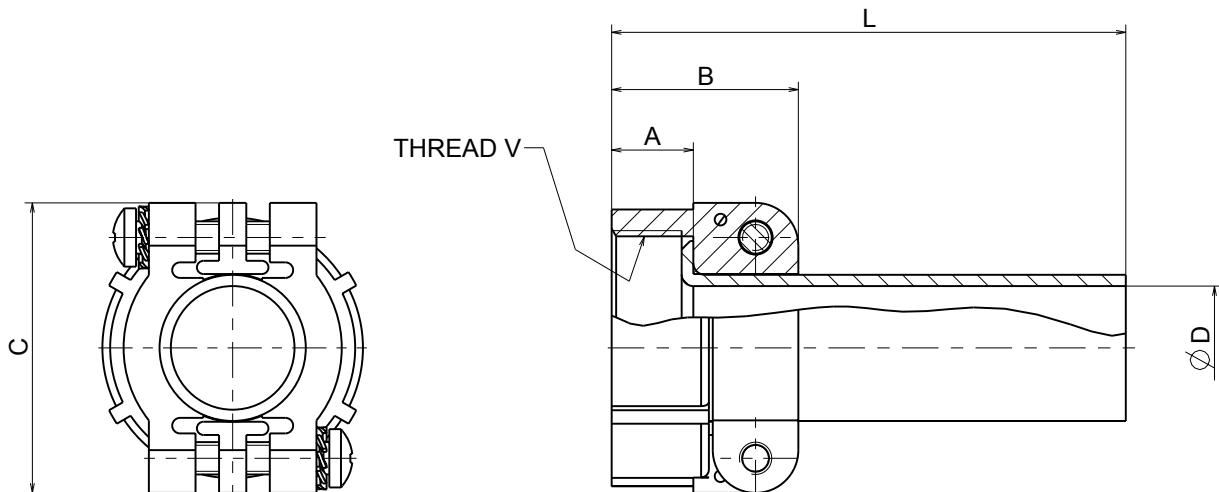

Part Number	Used with conn. size	A	B	C	ØD	L	Thread V
VE3057-8ABTXX	16-16S	10.5	24	28	11.1	72.2	7/8"-20 UNEF
VE3057-10ABTXX	18	10.5	28.5	33	14.3	69	1"-20 UNEF
VE3057-12ABTXX	20-22	10.5	24	35	15.9	66	1 3/16"-18 UNEF
VE3057-16ABTXX	24-28	10.5	26	43	19.1	63	1 7/16"-18 UNEF
VE3057-20ABTXX	32	12.5	28	51	23.8	62	1 3/4"-18 UNS
VE3057-24ABTXX	36	14	29.4	58	31.8	60	2"-18 UNS
VE3057-28ABTXX	40	14	42.8	65	35	57	2 1/4"-16 UN

Dimensions shown in mm  
Specifications and dimensions subject to change

**FRVE3057--C**

Waterproof cable clamp providing concentric clamping over the cable jacket.

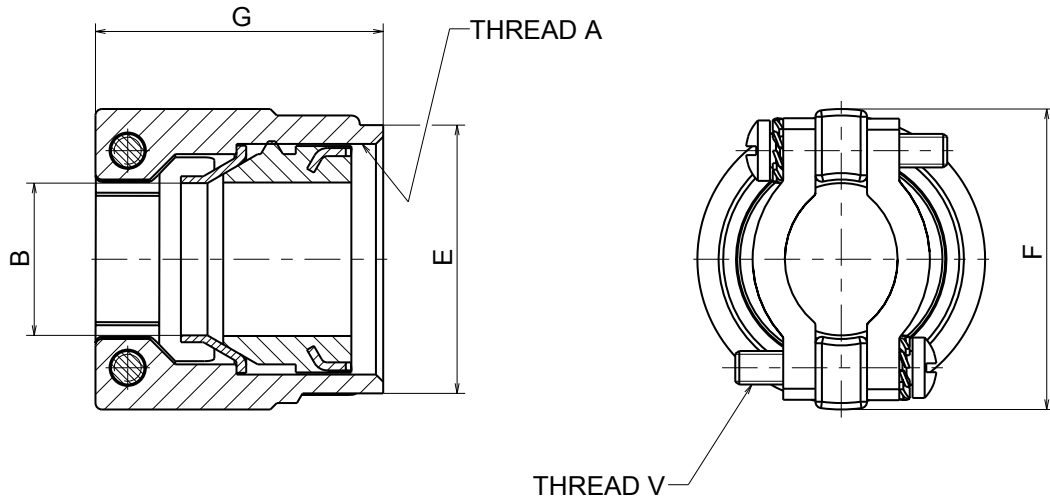

Part Number	Used With size	Thread A	B		E ±0.4	F ±0.2	G +0.5-0	Thread V
			Open	Closed				
FRVE3057-8CTXX	16-16S	7/8"-20 UNEF	13.48	8	25.4	28.1	32.3	6-32 UNC
FRVE3057-10CTXX	18	1"-20 UNEF	15.87	9.6	28.5	31	35.3	6-32 UNC
FRVE3057-12CTXX	20-22	1 3/16"-18 UNEF	19	11.3	33.3	37.3	35.7	8-32 UNC
FRVE3057-18CTXX	24-28	1 7/16"-18 UNEF	23.8	15.5	39.6	42	38.5	8-32 UNC
FRVE3057-20CTXX	32	1 3/4"-18 UNS	31.75	23.4	47.6	54	44.8	.250-20 UNC
FRVE3057-24CTXX	36	2"-18 UNS	35	23.4	53.9	57.1	51.6	.250-20 UNC
FRVE3057-28CTXX	40	2 1/4"-16 UN	41.25	29.9	60.3	63.5	51.6	.250-20 UNC

Dimensions shown in mm  
Specifications and dimensions subject to change

### SQUARE PANEL GASKET FOR FRONT MOUNTING RECEPTACLE

Used on front panel mounting receptacle (type VBN2)

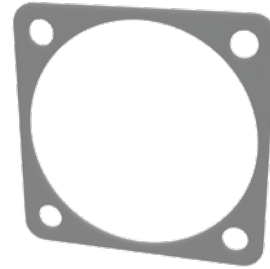
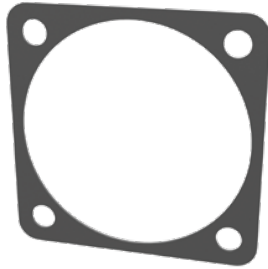

Not conductive square gasket ("N" type).  
Chloroprene rubber.  
Protection degree: IP67

Conductive square gasket ("NS" type).  
Silicone rubber with conductive filler  
Protection degree: IP65

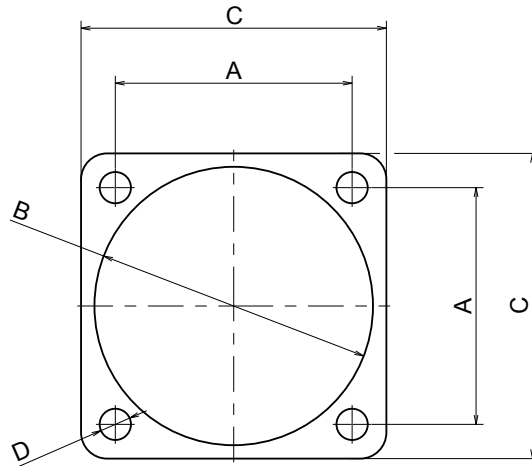

Size	A ±0.2	B +1 -0	C ±0.5	D +0.5 -0	"N" type (non-conductive) according to VG spec	"NS" type (conductive) according to VG spec
16-16S	24	25.3	32.5	4.2	VG95234 DA-16-1	VG95234 DA-16-2
18	27	28.4	35	4.2	VG95234 DA-18-1	VG95234 DA-18-2
20	29.4	31.6	38	4.2	VG95234 DA-20-1	VG95234 DA-20-2
22	31.8	34.8	41	4.2	VG95234 DA-22-1	VG95234 DA-22-2
24	34.9	38	44.5	4.2	VG95234 DA-24-1	VG95234 DA-24-2
28	39.7	44.3	50.8	5.1	VG95234 DA-28-1	VG95234 DA-28-2
32	44.5	50.7	57	5.1	VG95234 DA-32-1	VG95234 DA-32-2
36	49.2	57	63.5	5.1	VG95234 DA-36-1	VG95234 DA-36-2
40	55.5	61.9	70	5.6	16968	16968/1

Dimensions shown in mm  
Specifications and dimensions subject to change

### SQUARE PANEL GASKET FOR REAR MOUNTING RECEPTACLE

Used on rear panel mounting receptacle (type VBN3)

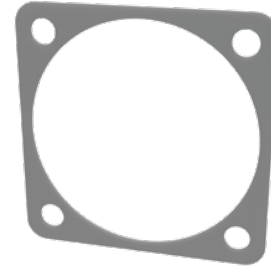
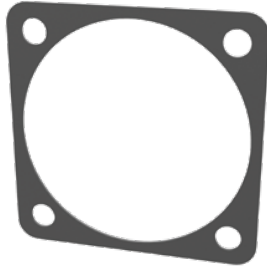

Not conductive square gasket ("N" type).  
Chloroprene rubber.  
Protection degree: IP67

Conductive square gasket ("NS" type).  
Silicone rubber with conductive filler  
Protection degree: IP65

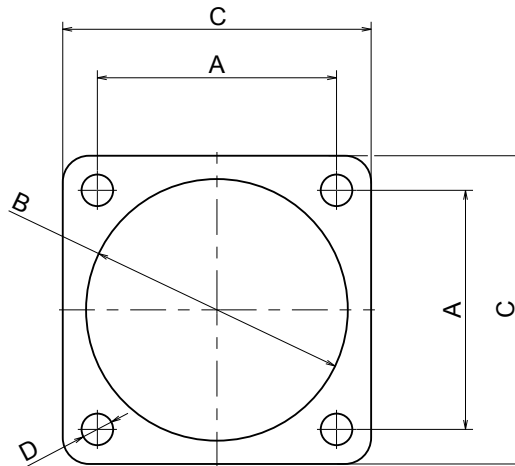

Size	A ±0.2	B +3 -0	C ±0.5	D +0.5 -0	"N" type (non-conductive) according to VG spec	"NS" type (conductive) according to VG spec
16-16S	24.6	27.4	32.5	4.2	VG95234 DH-16-1	VG95234 DH-16-2
18	27	30.8	35	4.2	VG95234 DH-18-1	VG95234 DH-18-2
20	29.4	34.2	38	4.2	VG95234 DH-20-1	VG95234 DH-20-2
22	31.8	37.4	41	4.2	VG95234 DH-22-1	VG95234 DH-22-2
24	34.9	40.9	44.5	4.2	VG95234 DH-24-1	VG95234 DH-24-2
28	39.7	46.7	50.8	5.1	VG95234 DH-28-1	VG95234 DH-28-2
32	44.5	53.4	57	5.1	VG95234 DH-32-1	VG95234 DH-32-2
36	49.2	59.6	63.5	5.1	VG95234 DH-36-1	VG95234 DH-36-2
40	55.5	65.5	69.9	5.1	46739-40	46739-40-1

Dimensions shown in mm  
Specifications and dimensions subject to change

**FRCIR--TF**

Metal dust cap with stainless steel chain and Flame Retardant gasket  
Used on receptacle.

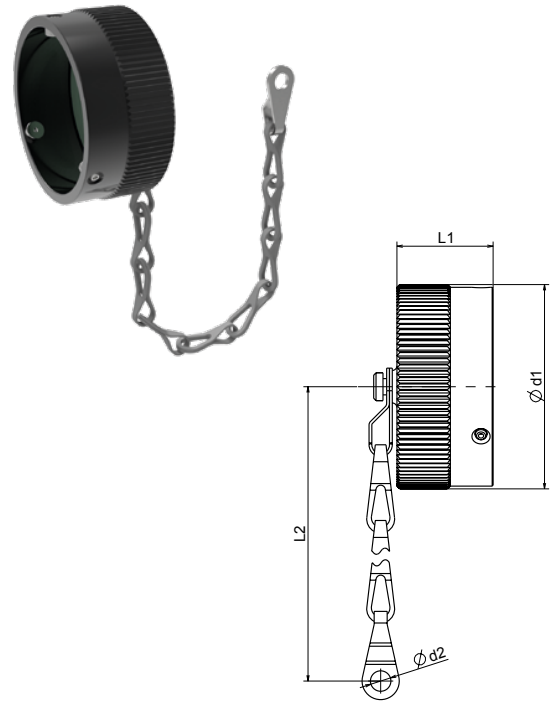

Part Number	Used on conn. size	D1 Max.	D2 +0.5-0	L1 ±0.2	L2 Approx.
FRCIR16STFTxx	16S	33	4.4	16	127
FRCIR18TFTxx	18	37.5	4.4	20.7	127
FRCIR20TFTxx	20	41	4.4	20.7	127
FRCIR22TFTxx	22	44	4.4	20.7	127
FRCIR24TFTxx	24	47.5	4.4	20.7	127
FRCIR28TFTxx	28	54.5	5.6	20.7	190
FRCIR32TFTxx	32	61	5.6	20.7	190
FRCIR36TFTxx	36	67.5	5.6	20.7	175
FRCIR40TFTxx	40	73	5.6	20.7	190

**CIR-TV**

Metal dust cap with stainless steel chain.  
Used on plug.

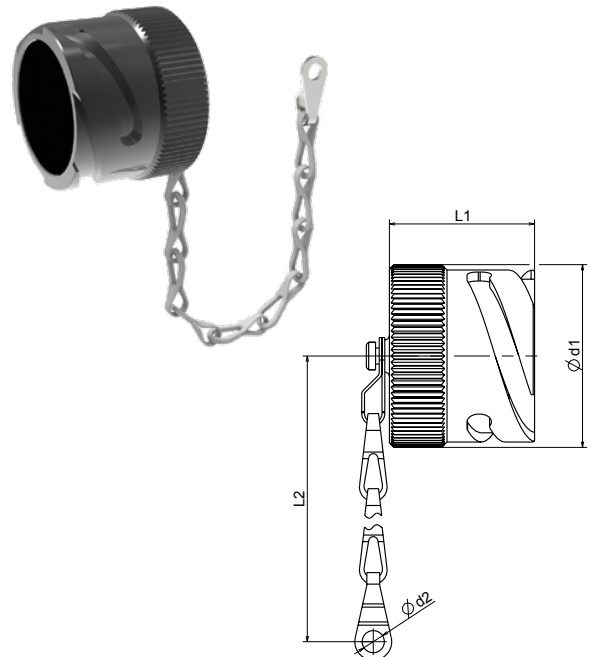

Part Number	Used on conn. size	D1 Max.	D2 +0.5-0	L1 ±0.2	L2 Approx.
CIR16STVTxx	16S	30	4.4	23.5	127
CIR18TVTxx	18	33.5	4.4	31.5	127
CIR20TVTxx	20	37	4.8	31.5	140
CIR22TVTxx	22	40	4.8	31.5	140
CIR24TVTxx	24	43.5	4.8	31.5	140
CIR28TVTxx	28	49.5	4.8	31.5	190
CIR32TVTxx	32	56	5.6	31.5	190
CIR36TVTxx	36	62.5	5.6	31.5	190
CIR40TVTxx	40	67.7	5.6	31.5	190

Dimensions shown in mm  
Specifications and dimensions subject to change

## PANEL CUT-OUT

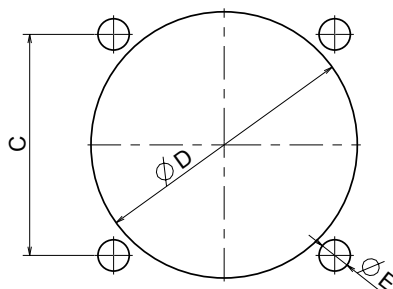

VBN3 Rear mounting panel cut-out dimensions

Shell Size	C ±0.1	D	ØE +0.1 -0
16S	24.6	28.3	4.5
18	27	31.7	4.5
20	29.4	35	4.5
22	31.8	38.3	4.5
24	34.9	41.8	4.5
28	39.7	47.6	5.5
32	44.5	54.3	5.5
36	49.2	60.5	5.5
40	55.5	66.4	5.5

VBN2 Front mounting panel cut-out dimensions

Shell Size	C ±0.1	D	ØE +0.1 -0
16S	24.6	23	3.4
18	27	26.5	3.4
20	29.4	30	3.4
22	31.8	33	3.4
24	34.9	36	3.9
28	39.7	42	3.9
32	44.5	48.5	4.5
36	49.2	55	4.5
40	55.5	61	4.5

## PANEL THICKNESS FOR REAR MOUNTING RECEPTACLE

Connector size	S Max.	
	VBN6	MGPVBN6
16S	7.2	
18	7.5	6.3
20	7.5	6.3
22	7.5	6.3
24	7.5	6.3
28	8.2	7
32	7.5	6.3
36	7.5	6.3
40	7.5	6.3

The panel dimension doesn't include the bolt head.

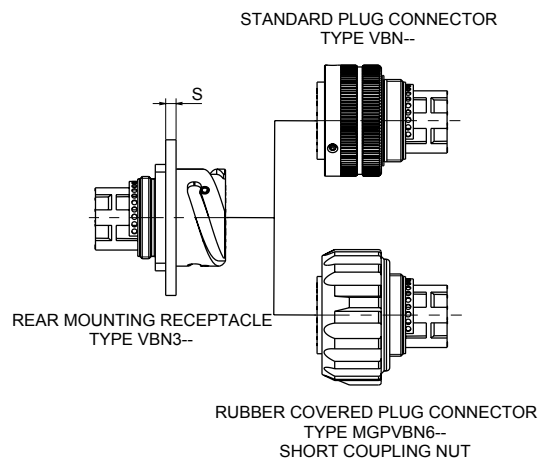

Dimensions shown in mm  
Specifications and dimensions subject to change

**BACKSHELL TORQUE VALUES**

Shell Size	Max. Backshell to Connector Tightening Torque (Nm)
16S	7.4
18	7.8
20	9.8
22	11.8
24	14.7
28	18.6
32	20.6
36	26.5
40	39.2

The above values are based upon the most densely populated contact arrangements with cables at the maximum limit for the grommet. The values are for guidance only.

**FIXING SCREW TORQUE VALUES**

Thread	Max. torque for screw at the flanges (Nm)
M3	1.2 ±0.2
M4	1.4 ±0.2
M5	2.0 ±0.2

The above values are based upon the most densely populated contact arrangements with cables at the maximum limit for the grommet. The values are for guidance only.

## Setting for authorized crimp tools PIN CONTACTS

Male Part number	Contact size	Cable		Crimping tool (see note)	Crimping die	Selector number	Tool position	Removal tool		
		DIN mm2	AWG							
51513-16S-12	16S	0.5	20	VM8 or CT8N(M)	VH435	3	Green	ET16VBN		
		0.75				4				
						3				
51513-16S-20	16S	1	14	VM8 or CT8N(M)	VH435	5	Green	ET16VBN		
		1.5				6				
51513-16S-26	16S	2.5/3	12	VM8 or CT8N(M)	VH435	7	Green	ET16VBN		
						8				
51513-16-12	16	0.5	20	VM8 or CT8N(M)	VH435	3	Blue	ET16VBN		
		0.75				4				
						3				
51513-16-20	16	1	14	VM8 or CT8N(M)	VH435	5	Blue	ET16VBN		
		1.5				6				
51513-16-26	16	2.5/3	12	VM8 or CT8N(M)	VH435	7	Blue	ET16VBN		
						8				
51513-12	12	2.5/3	12	CT8N (M)	VH435	7	Red	ET12VBN		
51513-12-12	12	0.5	20	CT8N (M)	VH435	3	Red	ET12VBN		
		0.75				4				
						3				
51513-12-20	12	1	14	CT8N (M)	VH435	7	Red	ET12VBN		
		1.5				18			8	
		2								
										7
51513-12-30	12	4		CT8N (M)	VH435	8	Red	ET12VBN		
51513-12-38	12	6		CT8N (M)	VH435	8	Red	ET12VBN		
51513-8	8		8	MP-F80-VGE (H)	44519-8T70			ET8VBN		
				HT45 (M)	51589-52T70					
				B50 (E)						
51513-8-20	8	1.0/2.0		MP-F80-VGE (H)	44519-8-1T70			ET8VBN		
51513-8-26	8	3	12	MP-F80-VGE (H)	44519-425T70			ET8VBN		
		3		HT45 (M)	51589-32T70					
		3	B50 (E)							
			12							
51513-8-30	8	4		MP-F80-VGE (H)	44519-44T70			ET8VBN		
			HT45 (M)	51589-37T70						
			B50 (E)							
51513-8-38	8	6		MP-F80-VGE (H)	44519-126T70			ET8VBN		
			HT45 (M)	51589-37T70						
			B50 (E)							
51513-8-50	8	10		MP-F80-VGE (H)	44519-8T70			ET8VBN		
			HT45 (M)	51589-52T70						
			B50 (E)							

Note: Manual= (M) Hydraulic= (H) Electrical= (E)

Dimensions shown in mm  
Specifications and dimensions subject to change

## Setting for authorized crimp tools SOCKET CONTACTS

Female Part number	Contact size	Cable		Crimping tool (see note)	Crimping die	Selector number	Tool position	Removal tool
		DIN mm2	AWG					
51511-16S-12	16S	0.5		VM8 or CT8N(M)	VH435	3	Green	ET16VBN
		0.75				4		
			20			3		
51511-16S-20	16S	1		VM8 or CT8N(M)	VH435	5	Green	ET16VBN
		1.5				6		
			14					
51511-16S-26	16S	2.5/3		VM8 or CT8N(M)	VH435	7	Green	ET16VBN
			12			8		
51511-16-12	16	0.5		VM8 or CT8N(M)	VH435	3	Red	ET16VBN
		0.75				4		
			20			3		
51511-16-20	16	1		VM8 or CT8N(M)	VH435	5	Red	ET16VBN
		1.5				6		
			14					
51511-16-26	16	2.5/3		VM8 or CT8N(M)	VH435	7	Red	ET16VBN
			12			8		
51511-12	12	2.5/3		CT8N (M)	VH435	7	Red	ET12VBN
			12					
51511-12-12	12	0.5		CT8N (M)	VH435	3	Red	ET12VBN
		0.75				4		
			20			3		
51511-12-20	12	1		CT8N (M)	VH435	7	Red	ET12VBN
		1.5				8		
		2						
			14					
			16					
		18		7				
51511-12-30	12	4		CT8N (M)	VH435	8	Red	ET12VBN
51511-12-38	12	6		CT8N (M)	VH435	8	Red	ET12VBN
51511-8	8		8	MP-F80-VGE (H)	44519-8T70			ET8VBN
				HT45 (M)	51589-52T70			
				B50 (E)				
51511-8-20	8	1.0/2.0		MP-F80-VGE (H)	44519-8-1T70			ET8VBN
51511-8-26	8	3	12	MP-F80-VGE (H)	44519-425T70			ET8VBN
		3	12	HT45 (M)	51589-32T70			
		3	12	B50 (E)				
			12					
51511-8-30	8			MP-F80-VGE (H)	44519-44T70			ET8VBN
		4		HT45 (M)	51589-37T70			
				B50 (E)				
51511-8-38	8			MP-F80-VGE (H)	44519-126T70			ET8VBN
		6		HT45 (M)	51589-37T70			
				B50 (E)				
51511 -8-50	8		10	MP-F80-VGE (H)	44519-8T70			ET8VBN
				HT45 (M)	51589-52T70			
				B50 (E)				

Note: Manual= (M) Hydraulic= (H) Electrical= (E)

Dimensions shown in mm  
Specifications and dimensions subject to change

## Setting for approved crimp tools

### PIN CONTACTS

Male Part number	Contact size	Cable		Crimping tool	Crimping die	Selector number	Tool position	Removal tool	
		DIN mm2	NF F mm2						
51513-16S-12	16S	0.5	0.60	FT8	TH685	6	Blue	ET16VBN	
		0.75				7			
		1	0.93			6			
51513-16S-20	16S	1.34	1.82	FT8	TH685	7	Blue	ET16VBN	
		1.5				8			
		2.5				2.61			8
51513-16S-26	16S	2.5	2.61	FT8	TH685	8	Blue	ET16VBN	
51513-16-12	16	0.5	0.60	FT8	TP1517	6		ET16VBN	
		0.75				7			
51513-16-20	16	0.93	1.34	FT8	TP1517	6		ET16VBN	
		1				7			
		1.5				8			
		1.82							
51513-16-26	16	2.5	2.61	FT8	TP1517	8		ET16VBN	
51513-12	12	2.5	2.61	FT8	TP1519	8		ET12VBN	
		0.5				7			
51513-12-12	12	0.60	0.93	FT8	TP1519	7		ET12VBN	
		0.75				8			
51513-12-20	12	1	1.34	FT8	TP1519	8		ET12VBN	
		1.5							
		1.82							
51513-12-30	12	4		FT8	TP1519	8		ET12VBN	
51513-12-38	12	6		FT8	TP1519	8		ET12VBN	
51513-8-20	8	0.93	1.34	M317	TP1520	4		ET8VBN	
		1.0							
		1.5							
51513-8-26	8	1.82	2.61	M317	TP1520	4		ET8VBN	
		2.5							
51513-8-30	8	4.0		M317	TP1520	5		ET8VBN	
51513-8-38	8	6.0		M317	TP1520	5		ET8VBN	

## Setting for approved crimp tools

### PIN CONTACTS

Female Part number	Contact size	Cable		Crimping tool	Crimping die	Selector number	Tool position	Removal tool	
		DIN mm2	NF F mm2						
51511-16S-12	16S	0.5	0.60	FT8	TH685	6	Red	ET16VBN	
		0.75				7			
		1	0.93			6			
51511-16S-20	16S	1.34	1.82	FT8	TH685	7	Red	ET16VBN	
		1.5				8			
		2.5				2.61			8
51511-16S-26	16S	2.5	2.61	FT8	TH685	8	Red	ET16VBN	
51511-16-12	16	0.5	0.60	FT8	TP1517	6		ET16VBN	
		0.75				7			
51511-16-20	16	0.93	1.34	FT8	TP1517	6		ET16VBN	
		1.5				7			
		1.82				8			
51511-16-26	16	2.5	2.61	FT8	TP1517	8		ET16VBN	
51511-12	12	2.5	2.61	FT8	TP1519	8		ET12VBN	
		0.5				7			
51511-12-12	12	0.60	0.93	FT8	TP1519	7		ET12VBN	
		0.75				8			
51511-12-20	12	1.34	1.82	FT8	TP1519	8		ET12VBN	
		1.5							
		1.82							
51511-12-30	12	4		FT8	TP1519	8		ET12VBN	
51511-12-38	12	6		FT8	TP1519	8		ET12VBN	
51511-8-20	8	0.93	1.34	M317	TP1520	4		ET8VBN	
		1.0							
		1.5							
51511-8-26	8	1.82	2.61	M317	TP1520	4		ET8VBN	
		2.5							
51511-8-30	8	4.0		M317	TP1520	5		ET8VBN	
51511-8-38	8	6.0		M317	TP1520	5		ET8VBN	

# ADDITIONAL VEAM SOLUTIONS FOR RAIL INFRASTRUCTURE AND ROLLING STOCK APPLICATIONS



## CIR/FRCIR Series



- Available with 1-159 poles, 256 layouts, 2,000 matching cycles
- Flame retardant (EN45545 HL3 - NFPA 130)
- Aluminium shells up to 500h salt spray resistance
- Stainless steel & marine bronze available



## DSR Series

- Double start ratchet threaded coupling mechanism with 5 Keyways
- Flame retardant (EN45545 HL3 - NFPA130)
- High shock resistance

## CIR M12 Series



- 1 way and 4 way versions, 3 types of contacts: 2, 4 & 8-pole
- Performance up to Category 7, supports communication speed up to 10Gbps
- Flame retardant (EN45545 HL3 - NFPA 130)



## Power Plate Series

- 2-3-4 pole versions, highly customizable according cable, current and voltage requirements
- Operating voltage according to EN50124-1
- Fast and easy coupling system with two screws or with latch mechanism

## CIR290 Series



- Available with 3 to 101 poles, from 7.5 to 350 A, 2,000 mating cycles
- Flame retardant (EN45545 HL3 - NFPA 130)
- Aluminium shells up to 500h salt spray resistance



## VRPC Series

- Available with 3,6,12 way layouts, machined or stamped contacts
- Smoke & fire resistance per NFF16-101 & NFF16-102
- IP20 or IP67
- Rear removable cable support or Rear backshells

## HTB Series



- High Temperature Bayonet connector, tested at 800°C for 30 minutes
- Exceeds the standard ISO 834-1
- Creates a REI 0 fire barrier according EN13501-2 / EN 1363-1



## CIR Fiber Optic Series

- Available with 4 to 22 multimode or singlemode fibers
- Supports communication speed up to beyond 10 Gbps
- Customized harnessing service on request

THIS NOTE MUST BE READ IN CONJUNCTION WITH THE PRODUCT DATA SHEET/CATALOG. FAILURE TO OBSERVE THE ADVICE IN THIS INFORMATION SHEET AND THE OPERATING CONDITIONS SPECIFIED IN THE PRODUCT DATA SHEET/ CATALOG COULD RESULT IN HAZARDOUS SITUATIONS.

## ▶ 1. MATERIAL CONTENT AND PHYSICAL FORM

Electrical connectors do not usually contain hazardous materials. They contain conducting and non-conducting materials and can be divided into two groups.

- a) Printed circuit types and low cost audio types which employ all plastic insulators and casings.
- b) Rugged, Fire Barrier and High Reliability types with metal casings and either natural rubber, synthetic rubber, plastic or glass insulating materials. Contact materials vary with type of connector and also application and are usually manufactured from either: Copper, copper alloys, nickel, alumel, chromel or steel. In special applications, other alloys may be specified.

## ▶ 2. FIRE CHARACTERISTICS AND ELECTRIC SHOCK HAZARD

There is no fire hazard when the connector is correctly wired and used within the specified parameters. Incorrect wiring or assembly of the connector or careless use of metal tools or conductive fluids, or transit damage to any of the component parts may cause electric shock or burns. Live circuits must not be broken by separating mated connectors as this may cause arcing, ionization and burning. Heat dissipation is greater at maximum resistance in a circuit. Hot spots may occur when resistance is raised locally by damage, e.g. cracked or deformed contacts, broken strands of wire. Local overheating may also result from the use of the incorrect application tools or from poor quality soldering or slack screw terminals. Overheating may occur if the ratings in the product Data Sheet/ Catalog are exceeded and can cause breakdown of insulation and hence electric shock. If heating is allowed to continue it intensifies by further increasing the local resistance through loss of temper of spring contacts, formation of oxide film on contacts and wires and leakage currents through carbonization of insulation and tracking paths. Fire can then result in the presence of combustible materials and this may release noxious fumes. Overheating may not be visually apparent. Burns may result from touching overheated components.

## ▶ 3. HANDLING

Care must be taken to avoid damage to any component parts of electrical connectors during installation and use. Although there are normally no sharp edges, care must be taken when handling certain components to avoid injury to fingers. Electrical connectors may be damaged in transit to the customers, and damage may result in creation of hazards. Products should therefore be examined prior to installation/ use and rejected if found to be damaged.

## ▶ 4. DISPOSAL

Incineration of certain materials may release noxious or even toxic fumes.

## ▶ 5. APPLICATION

Connectors with exposed contacts should not be selected for use on the current supply side of an electrical circuit, because an electric shock could result from touching exposed contacts on an unmated connector. Voltages in excess of 30 V ac or 42.5 V dc are potentially hazardous and care should be taken to ensure that such voltages cannot be transmitted in any way to exposed metal parts of the connector body. The connector and wiring should be checked, before making live, to have no damage to metal parts or insulators, no solder blobs, loose strands, conducting lubricants, swarf,

or any other undesired conducting particles. Circuit resistance and continuity check should be made to make certain that there are no high resistance joints or spurious conducting paths.

Always use the correct application tools as specified in the Data Sheet/ Catalog. Do not permit untrained personnel to wire, assemble or tamper with connectors. For operation voltage please see appropriate national regulations.

## IMPORTANT GENERAL INFORMATION

### (i) Air and creepage paths/Operating voltage.

The admissible operating voltages depend on the individual applications and the valid national and other applicable safety regulations. For this reason the air and creepage path data are only reference values. Observe reduction of air and creepage paths due to PC board and/or harnessing.

### (ii) Temperature

All information given are temperature limits. The operation temperature depends on the individual application.

### (iii) Other important information

Cannon continuously endeavors to improve their products. Therefore, Cannon products may deviate from the description, technical data and shape as shown in this catalog and data sheets.

# NOTES



A large area of the page is filled with horizontal dashed lines, providing a space for handwritten notes.

Dimensions shown in mm  
Specifications and dimensions subject to change

Connect with your ITT Veam representative today  
or visit us at [www.ittcannon.com](http://www.ittcannon.com)

## Connect with the experts

ITT Veam's brand is a world leader in the design and manufacture of highly engineered connector solutions for multiple end markets.



ENGINEERED FOR LIFE

### North America

56 Technology Drive  
Irvine, CA 92618  
Phone 1.800.854.3028

100 New Wood Road  
Watertown, CT 06795  
Phone: +1.860.274.9681

### Europe

Italy  
Corso Europa 41/43  
I - 20020 Lainate (MI) Italy  
Phone: +39.02938721

Germany  
Cannonstrasse 1  
D - 71384 Weinstadt, Germany  
Phone: +49.7151.699.0

### Asia

Tuopandun Industrial Area, Jinda Cheng,  
Xiner Village, Shajing Town, Boan District,  
Shenzhen City, Guangdong Province, China 518215  
Phone: +86.755.2726.7888