













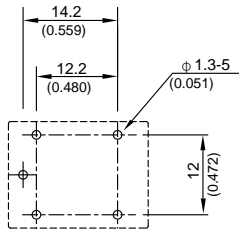
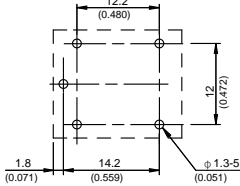
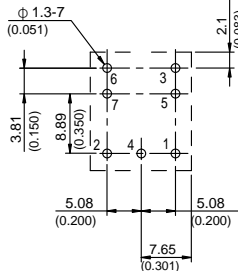
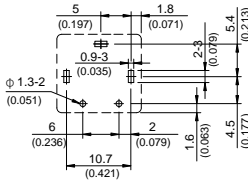



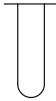

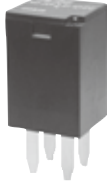
# Relays Selection Chart





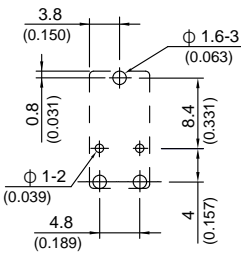
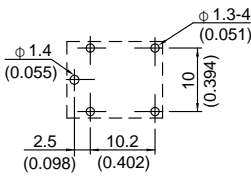
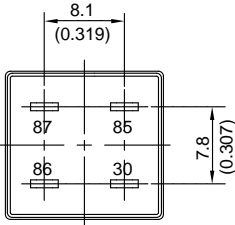
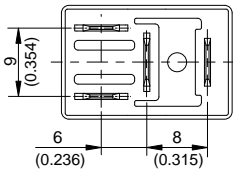
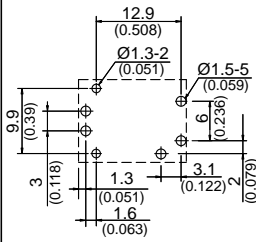
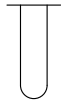
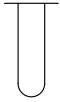
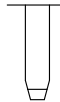
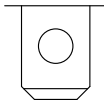
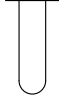

Type		812HM	833HM	861	102
Photo					
	Description				
Outline (L×W×H) mm No including terminals		21 × 16 × 16.3	19 × 15.5 × 15	17.5 × 15 × 19.5	14.2 × 13.2 × 9.7
Contact configuration		1A · 1C	1A · 1B · 1C	SP DM-DB	1A · 1C
Max. Allowable Contact current (A)	45	15A	15A	15A	20A
	40				
	35				
	30				
	25				
	20				
	15				
	10				
5					
3					
Contact rating Resistive load		15A 14VDC	15A 14VDC	15A 14VDC SPDM : 10A×2 14VDC	NO : 20A 14VDC NC : 10A 14VDC
Coil voltage	DC	9 · 12 · 24V	9 · 12 · 24V	6 · 9 · 12 · 24V	6 · 9 · 12 · 24V
	AC	-----	-----	-----	-----
Power consumption	DC	0.64W	0.45W	1.1W	0.64W
	AC	-----	-----	-----	-----
Life expectancy					
Mechanical (Min.)		1×10 <sup>7</sup>	1×10 <sup>7</sup>	1×10 <sup>7</sup>	1×10 <sup>7</sup>
Electrical (Min.)		1×10 <sup>5</sup>	3×10 <sup>4</sup>	1×10 <sup>5</sup>	1×10 <sup>5</sup>
Dielectric strength					
Open contact		500VAC	500VAC	500VAC	500VAC
Contact and coil		500VAC	500VAC	500VAC	500VAC
Contact circuits		-----	-----	-----	-----
Terminal layout					
mm (inch) Bottom view (PCB layout)					
Terminal type					
Page no.		209~211	212~214	215~218	219~221

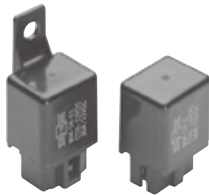

# Relays Selection Chart

103	895	303	108	905
				
14.4 × 7.6 × 13.7	15.5 × 12 × 13.8	16 × 15 × 23.7	22.5 × 15 × 16	16.6 × 12.6 × 17
1A · 1C	1A · 1C · 2A	1A	1A	1A · 1C
				
NO : 20A 14VDC NC : 10A 14VDC	NO : 20A 14VDC NC : 10A 14VDC	20A 14VDC 10A 28VDC	25A 14VDC	NO : 30A 14VDC NC : 20A 14VDC
6 · 9 · 12 · 24V	5 · 9 · 12 · 24V	12 · 24V	12V	12V
-----	-----	-----	-----	-----
0.64W	0.64W · 1.0W · 0.8W	0.96W	0.8W	0.72W
-----	-----	-----	-----	-----
1 × 10 <sup>7</sup>	1 × 10 <sup>7</sup>	1 × 10 <sup>7</sup>	1 × 10 <sup>6</sup>	1 × 10 <sup>7</sup>
1 × 10 <sup>5</sup>	1 × 10 <sup>5</sup>	1 × 10 <sup>5</sup>	1 × 10 <sup>5</sup>	1 × 10 <sup>5</sup>
500VAC	500VAC	500VAC	500VAC	500VAC
500VAC	500VAC	500VAC	500VAC	500VAC
-----	-----	-----	-----	-----
				
		280 		
222~224	225~228	229~231	232~233	234~235

# Relays Selection Chart

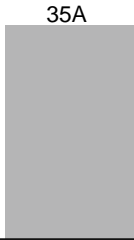
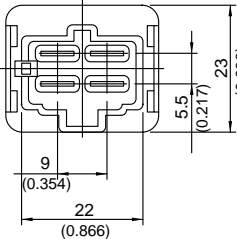
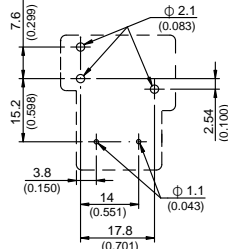
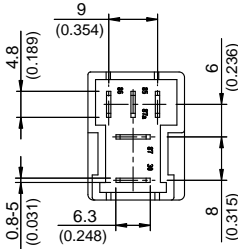
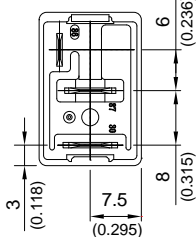
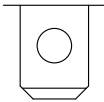
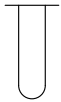
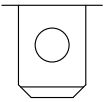
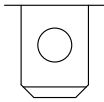



Type		804	832AM	871	871A
Photo	Photo				
	Description				
Outline (L×W×H) mm No including terminals		27.7 × 23 × 29.3	32.2 × 27.5 × 20.4	23 × 15.5 × 25.4	22.5 × 15 × 25.4
Contact configuration		1A	1A、1C	1A、1C	1A
Max. Allowable Contact current (A)	45				
	40				
	35				
	30				
	25				
	20				
	15				
	10				
5					
3					
Contact rating Resistive load		30A 12VDC 15A 24VDC	1A : 30A 14VDC 1C : NO 20A/NC 10A 14VDC	NO : 35A 14VDC 15A 28VDC NC : 20A 14VDC 10A 28VDC	35A 14VDC
Coil voltage	DC	12、24V	9、12、24V	6、12、24V	12V
	AC	-----	-----	-----	-----
Power consumption	DC	1.4W	0.93W	1.2W	1.2W
	AC	-----	-----	-----	-----
Life expectancy					
Mechanical (Min.)		5×10 <sup>6</sup>	1×10 <sup>7</sup>	1×10 <sup>7</sup>	1×10 <sup>6</sup>
Electrical (Min.)		1×10 <sup>5</sup>	1×10 <sup>5</sup>	1×10 <sup>5</sup>	1×10 <sup>5</sup>
Dielectric strength					
Open contact		500VAC	500VAC	500VAC	500VAC
Contact and coil		500VAC	500VAC	500VAC	500VAC
Contact circuits		-----	-----	-----	-----
Terminal layout					
mm (inch) Bottom view (PCB layout)					
Terminal type					
Page no.		236~238	239~241	242~245	246~247



# Relays Selection Chart

301	611	822E OPEN	822E Cover	896
22.5 × 15 × 25	22.5 × 15 × 25.4	25 × 21 × 20	26.6 × 21.4 × 21.8	25.8 × 25.8 × 25
1A · 1C	1A	1A · 1B · 1C	1A · 1B · 1C	1A · 1B · 1C · 2A
NO : 35A 14VDC 15A 28VDC NC : 20A 14VDC 10A 28VDC	35A 14VDC	1A : 40A 14VDC 1B : 30A 14VDC 1C : NO 40A/NC 20A 14VDC	1A : 40A 14VDC 1B : 30A 14VDC 1C : NO 40A/NC 20A 14VDC	896H : 50A 14VDC 20A 28VDC 896 : 40A 14VDC
6 · 12 · 24V	12V	6 · 9 · 12 · 24V	6 · 9 · 12 · 24V	12 · 24V
-----	-----	-----	-----	-----
1.2W	1.2W	1.6W · 1.2W	1.6W · 1.2W	1.6W
-----	-----	-----	-----	-----
1 × 10 <sup>7</sup>	1 × 10 <sup>6</sup>	1 × 10 <sup>7</sup>	1 × 10 <sup>7</sup>	1 × 10 <sup>7</sup>
1 × 10 <sup>5</sup>	1 × 10 <sup>5</sup>	1 × 10 <sup>5</sup>	1 × 10 <sup>5</sup>	1 × 10 <sup>5</sup>
500VAC	500VAC	500VAC	500VAC	500VAC
500VAC	500VAC	500VAC	500VAC	500VAC
-----	-----	-----	-----	-----
248 ~ 250	251 ~ 252	253 ~ 257	253 ~ 257	258 ~ 263

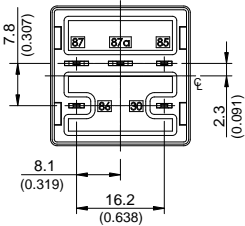
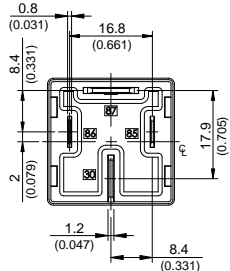
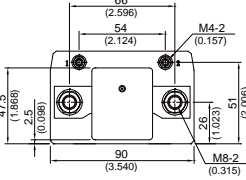
# Relays Selection Chart

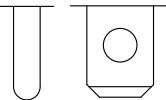
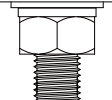
Type	898	897	409	
Photo				
Description				
Outline (L×W×H) mm No including terminals	25.8 × 25.8 × 25	25.8 × 25.8 × 25	90 × 58 × 49.5	
Contact configuration	1A · 1B · 1C	1A	1A	
Max. Allowable Contact current (A)	45	50A	70A	200A
	40			
	35			
	30			
	25			
	20			
	15			
	10			
5				
3				
Contact rating Resistive load	898H: 50A 14VDC 20A 28VDC 898: 40A 14VDC	70A 14VDC 25A 28VDC	200A 24VDC	
Coil voltage	DC	12 · 24V	12 · 24V	24V
	AC	-----	-----	-----
Power consumption	DC	1.6W	1.6W	4.8W
	AC	-----	-----	-----
Life expectancy Mechanical (Min.)		1×10 <sup>7</sup>	1×10 <sup>7</sup>	1×10 <sup>6</sup>
	Electrical (Min.)	1×10 <sup>5</sup>	1×10 <sup>5</sup>	5×10 <sup>4</sup>
Dielectric strength	Open contact	500VAC	500VAC	1000VAC
	Contact and coil	500VAC	500VAC	1000VAC
	Contact circuits	-----	-----	-----
Terminal layout				
mm (inch) Bottom view (PCB layout)				
Terminal type	280 			
Page no.	264~268	269~274	275~276	



# Cross Reference Sheet

Song Chuan	NAIS	TE	OMRON	F & T	HONGFA
102	CP1	( $\mu$ K/V23086)	-----	-----	HFKC
103	CT	V23138	G8N-1, G8NW-2 G8ND-2	FTR-P3	HFKA/HFKA-T
108	CV	-----	G8HL	-----	-----
301	-----	VJ28	G8V	-----	HFV9
303	-----	VH28	G8VL	-----	HFV11
804	CA	-----	-----	-----	-----
812HM	JSM	-----	G8SN	FBR161	HFKE
822	-----	V23076/V23133 Power relay K (VKP)	G8PE	FRL274	HFKP
861	-----	V23072	-----	-----	HFKM
871	CM	VFM/V23074	G8H	-----	HFV6
895	JJM	-----	G8QN	FBR51/52	HFKW
896	CB	F4 VF4	G8JN	-----	HFV4
897	CB	VF7, F7	G8JR	-----	HFV7
898	----	VF28	G8W	-----	HFV28
905	TG	-----	-----	FBR-53	-----

\* Relay part numbers change frequently. All crosses should be verified against technical specifications for accuracy.



# Standard packaging

Relay series	Dimensions[(LxWxH) cm]	PCS / Tube, Tray	PCS / Box	G.W. kg / Box
102	42.0×19.7×14.4	25 / Tube	1000	6
103	46.8×16.8×16.5	50 / Tube	1000	5.4
103T	46.8×16.8×16.5	25 / Tube	500	5.4
108	55.1×20.3×14.1	20 / Tube	500	9.5
301	42.4×30.6×28.2	25 / Tray	500	12
303	35.0×29.6×30.2	25 / Tray	500	9
409	54.5×40.5×26.5	8 / Tray	48	19.6
804 (C,C1)	41.6×35.7×35.1	25 / Tray	500	21
804 (C2)	62.6×49.0×20.9	50 / Tray	500	19.1
804 (C3)	44.0×39.0×34.4	25 / Tray	500	22.5
812HM	47.3×23.3×18.8	25 / Tube	1000	11
822 (open)	41.0×34.5×27.0	50 / Tray	1000	19.2
822 (C)	49.6×42.5×19.0	50 / Tray	500	13
832AM	44.6×39.8×24.8	50 / Tray	500	16
833HM	37.8×25.6×14.6	20 / Tube	1000	11
861	36.7×23.6×16.8	20 / Tube	1000	12
861T	36.7×23.6×16.8	10 / Tube	500	12
861 (open)	44.0×30.0×16.6	100 / Tray	1000	10
871 (DF)	51.2×36.4×20.9	50 / Tray	500	13.4
871 (C), 871A, 611	44.4×33.1×20.3	50 / Tray	500	11.8
895	36.7×18.4×17.3	25 / Tube	1000	7.2
896, 897	42.4×32.9×32.6	25 / Tray	400	16
896P, 897P	58.6×21.0×18.0	20 / Tube	400	16
898	42.4×32.9×32.6	25 / Tray	400	16
905	39.4×19.6×19.1	25 / Tube	1000	11.5

# Technical Information

## ■ INTRODUCTION

The technical information is divided into four basic parts:

- (1) General application guidelines.
- (2) Guidelines for relay handling.
- (3) Guidelines for selecting contact protection circuits.
- (4) Guidelines for selecting a temperature tolerant relay for your application.

In addition to the technical information, all data sheets in this catalog also include notes relevant to each specific relay. Please refer to these relay-specific notes, as they contain information vital to optimum relay performance.

## ■ GENERAL APPLICATION

### 1. Avoid Abuse

As with any electro-mechanical device, relays are sensitive to abuse. To assure optimum performance, avoid dropping, hitting, or other unnecessary shocks to the relay.

### 2. Never Remove the Case

The case of a relay is an integral part of that relay. SONG CHUAN relays are not designed to have the case detached. Never remove the case, as specifications or performance cannot be guaranteed.

### 3. Atmosphere Considerations

SONG CHUAN recommends that you use unsealed relays in an atmosphere with only a minimum of dust and other contaminants. If a relay must withstand a harsh atmosphere, SONG CHUAN recommends that you utilize a sealed relay.

### 4. Warning--Silicon Based Resins

Some silicon based resins can cause contact failure in a relay. The silicon based resin does not need to come in direct contact to cause damage—it just needs to be in close proximity. In cases where silicon based resins are used, it is recommended that a sealed relay be used.

### 5. Voltage

To assure meeting to electrical and performance characteristics, only the correct rated voltage should be applied to the coil, i.e., voltage sine waves only for AC coils, rectangular for DC coils.

### 6. Over Voltage

Although typically a spike will not effect a relay's performance, the voltage on the coil should not continuously exceed the maximum allowable voltage.

### 7. Contact Current

Currents that exceed the designated values should be avoided.

### 8. Check Your Load and Conditions

The specifications provided in this catalog are "typical" specifications and are given only as guidelines. The performance of contacts vary depending on both the type of load and operating conditions encountered. Please consider your specific load and operating conditions in selecting the optimum relay for your application.

### 9. Warning--Ambient Temperature

The ambient temperature ranges, listed in the general specifications for each relay, must be adhered to, to assure proper operation. Note: Both the storage and operating range differs for the sensitive and standard version of the same model. Refer to the data sheet of the relay for specific information.

### 10. Ultrasonic Cleaning

Never use any type of ultrasonic cleaning. Ultrasonic cleaning is always traumatic and is not recommended.

### 11. Pickup & Dropout Voltages

Both pickup and dropout voltages should be considered when selecting a relay coil voltage. For specific information, contact us.

### 12. Relay Coil Transient Suppression

The use of a single diode in parallel with the coil for transient suppression causes longer contact release time. On power relays, longer release time may reduce relay life. For longer contact life, use a zener and diode, a capacitor and resistor, or only a resistor.

### 13. Storage

Avoid storing relays in excessively humid conditions where possible, as moisture can affect performance in some cases.

## ■ RELAY HANDLING

SONG CHUAN utilizes extensive quality control measures, and takes extreme care in packaging to assure that the relays you receive are in the best possible operating condition. Once they enter your facility, some common sense care can prevent damage during handling. Some areas to closely monitor and supervise include:

### 1. Handling

#### ◆ Avoid handling relay terminals.

Oils and contaminants common to the human hand can cause contamination of the surface finish--which in turn can lead to solder ability problems.

#### ◆ Always store relays at recommended temperatures.

Observe maximum storage temperatures listed in the general specifications section of the data sheet for your specific relay.

#### ◆ Avoid misalignment of the terminal layout and PC board hole pattern.

Even if there is just a slight misalignment, forcing a relay into the board can cause relay damage compromising such important factors as seal integrity, relay performance, and relay reliability.

#### ◆ Store handle relays in a clean environment.

Your relays are state-of-the-art, electromechanical components, and should be stored and handled as such. Even environmentally sealed relays have exposed contacts that are subject to contamination, and therefore are minimally sensitive to their storage and production environment.

### 2. Mounting

#### ◆ Suggested PC board layout.

Refer to the PC board layout located on the data sheet for your specific relay.

#### ◆ For automatic insertion.

SONG CHUAN relays are available packaged for a variety of automatic insertion machines. Please consult with our Technical Services Department.

#### ◆ Never bend terminals.

Once relay terminals are bent, performance can no longer be guaranteed. Never bend terminals to make them self-clinching, and avoid bending them to fit misaligned holes.

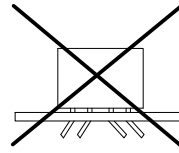

**Incorrect**  
Bending the relay leads, for any reason, can cause failure.

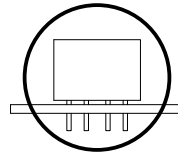

**Correct**  
Relay terminals remain straight and penetrate completely through the PC board.

#### ◆ Connection and mounting.

To connect a lead wire to the terminal or to mount the relay on a PC board, securely wind the lead wire around the terminal as shown.

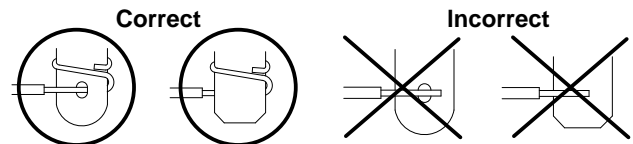

### 3. Soldering and washing guidelines

#### ◆ Flux coating

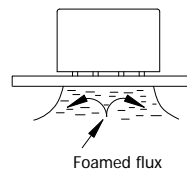

- Adjust the position of the PC board so that flux does not overflow onto the top of it.
- Use rosin-based flux, which is non-corrosive and requires no washing.
- Do not use Automatic Flux Coating Method to dust-cover type relays.
- Do not overflow onto the top of PC board, in such a case, the flux may even penetrate a flux-resistant type relay.

#### ◆ Preheating

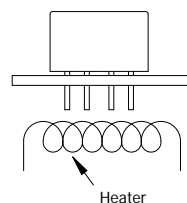

- Be sure to preheat before soldering.
- Preheating acts to improve solder ability.
- Preheat according to the following conditions:  
Temperature--100°C/212°F or less  
Time within--approx. 1 minute

# Technical Information

## ◆ Soldering

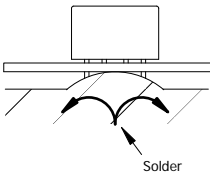

### Automatic Soldering

- Flow solder is the optimum method for soldering.
- Adjust the level of solder so that it does not overflow onto the top of the PC board.
- Unless otherwise specified, solder under the following conditions depending on the type of relay.
- Solder Temperature---approx. 250°C/482°F for SnPb soldering, 260°C/500°F for Lead-free soldering.
- Soldering Time---within approx. 5 seconds
- Solder Ratio--- Sn/Pb = 60/40 or 63/37

### Hand Soldering

- Keep the tip of the soldering iron clean.
- Solder Iron---30W to 60W.
- Iron Tip Temperature--approx. 300°C/572°F
- Solder Time---within approx. 3 seconds

## ◆ Cooling

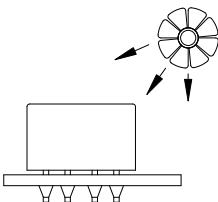

- Immediate air cooling is recommended to prevent deterioration of the relay and surrounding parts due to soldering heat.
- Although the sealed type relay can be cleaned, avoid immersing the relay into cold liquid (such as washing solvent) immediately after soldering. Doing so may deteriorate the sealing performance.

## ◆ Washing

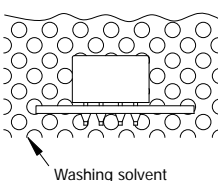

- Do not wash flux-resistant type relays and dust cover type relays by immersion.
- Careless washing may cause washing solvent to penetrate the relay.
- Plastic sealed type relays can be washed by immersion. Use washing solvents shown in Table 1.

- Use of other washing solvents may damage the relay case and cover, and also cause washing solvent to penetrate the relay.
- Washing with the boiling methods is recommended. Avoid ultrasonic washing on relays. Use of ultrasonic cleaning may cause breaks in the coil or slight sticking of contacts due to the ultrasonic energy.

Table 1. Washing solvent compatibility chart for sealed type relays.

	Flourinated	Aqueous	Chlorinated	Alcoholic
Solvent trade name	Freon TF	Aqua flux	Perclean B-5	IPA
	Freon TE	#WL 1000	Perclean D	Ethanol
	Freon TES	Indusco 624	Cholorothene VG	
	Freon TMC	Indusco1000	Cholorothene N	
	Alpha 1001	Lonco terge 530	Cholorosolve	
	Alpha 1003	Hollis 310	Alpha 564	
		Lonco Terg	Trichloroethan	

## ◆ Coating

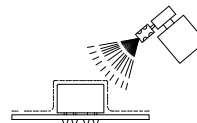

- If the PC board is to be coated to prevent the insulation of the PC board from deteriorating due to corrosive gases and high temperature, note the following.
- Do not coat dust-cover type relays and flux-resistant type relays.
- Depending on the type, some coating materials may have an adverse affect on relays, select coating materials carefully.
- Not to use silicon based resins.

## 4.Surface Mounting

### ◆ Cream solder printing

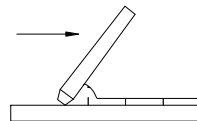

- Please use the cream solder that contains a flux without a large of chlorine, to avoid the terminal being corroded.

### ◆ Mounting

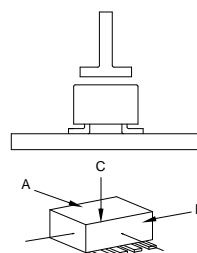

- The holding pressure on relay must be equal or less than the following reference. Or we can't guarantee the relay performance.  
 Direction A: 1.96N max.  
 Direction B: 4.9N max.  
 Direction C: 1.96N max.

## ◆ Reflow soldering

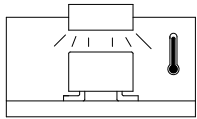

- Recommended conditions of soldering for example, as following. (The temperature profile shows the temperature on the PC board side.)
- Don't make the relay in a cold washing solvent instantly after soldering, to avoid the seal ability of relay being damaged.

### (1) IRS method (for SnPb solder)

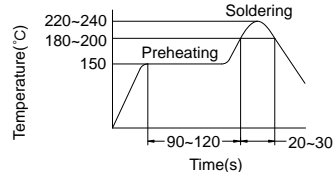

### (2) IRS method (for Pb-Free solder)

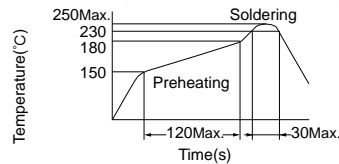

### (3) VPS method

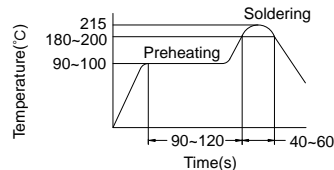

## ◆ Washing

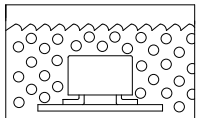

- Washing by boiling method and immersion is recommended.
- Use of ultra-sonic cleaning may cause break in the coil or slight sticking of contacts.
- Recommended washing solvent are aqueous solvent & alcoholic solvent. Furthermore, the solvent temperature must be within 40°C.

### Washing solvent

	Chlorinated	Aqueous	Alcoholic
Solvent	Perochlene	Indusco	IPA
	Chlorosolder	Holys	Ethanol

## ■ CONTACT PROTECTION CIRCUIT

A contact protection circuit, designed to prolong the life expectancy of the relay is recommended. This protection will have the additional advantage of suppressing noise, as well as preventing the generation of carbon at the contact surface when the relay contact is opened. However, unless designed correctly, the protection circuit may produce adverse effects, such as prolonging the release time of the load. The following table lists examples of contact protection circuits:

## DIODE AND ZENER DIODE CIRCUIT

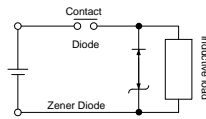

- DC applications only.
- Utilize when diode circuit causes longer turn off time on the load.
- Use zener diode with zener voltage about equal to power supply voltage.

## DIODE CIRCUIT

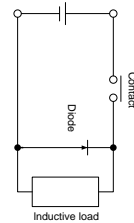

- DC applications only.
- Compared to RC type, circuit delays longer turn off time on the load.
- For larger voltages, use diode with reverse breakdown 10 times circuit voltage and forward load circuit.
- For smaller voltages, use reverse breakdown v or 2 to 3 X power supply voltage.

## RC CIRCUITS

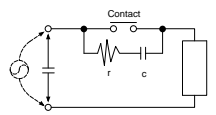

- This circuit is suitable for AC or DC Contact applications, but if used with AC voltage, impedance of the load should be smaller than the RC circuit's. Do not utilize for timer loads, as leakage current can cause faulty operation.

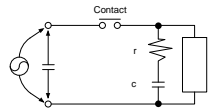

- This circuit is suitable for AC or DC. If Circuit the load is a relay or solenoid, release times lengthen. Effective when connected to both contacts, power supply voltage across the load is 100 to 200V.
- As a guide in selecting c and r, c: 0.5 to 1μF per 1A contact current, r: 0.5 to 1Ω per 1V contact voltage.

## VARISTOR CIRCUIT

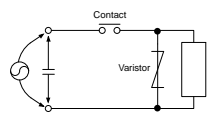

- Effective for AC & DC applications.
- Circuit slightly delays release time. Effective when connected to both contacts, power supply voltage across the load is 100 to 200V.

## Inrush Current

The type of load combined with it's inrush current characteristics, together with switching frequency can cause contact welding. For loads with inrush current, measure the steady state current and inrush current to determine the proper relay. Typical types of loads and the inrush current they create are shown in Table 2. Note that the effect of wiring resistance can reduce the inrush currents to less than the levels shown.

Table 2

Type of load	Inrush current
Resistive	Steady state current.
Solenoid	10~20 times the steady state current.
Motor	5~10 times the steady state current.
Incandescent lamp	10~15 times the steady state current.
Mercury lamp	3 times the steady state current.
Sodium vapor lamp	1~3 times the steady state current.
Capacitive	20~40 times the steady state current.
Transformer	5~10 times the steady state current.

# Technical Information

## ■ TEMPERATURE TOLERANT RELAY

More and more applications require relays that operate at higher temperatures. Relays run "hot" due to high ambient temperatures and/or high contact switching. These "hotter" environments can destroy a relay's insulation system and lead to product failure in the field.

To help prevent this type of failure, SONG CHUAN has, for several years, offered UL Class A, Class B, Class F insulating systems on its miniature power relays. Class F relays have significant "heat" advantage over Class A or Class B relays that, by contrast, only offer a rating of 105°C (Class A) or 130 °C (Class B) . This Class F insulating system is designated by UL and it is rated at a full 155°C. This section is a discussion of why and when an engineer needs to select a high temperature rated for the application.

First, let's define an insulation system, as it pertains to this application note. An insulation system may be defined as simply any combination of insulating materials used in electrical equipment. In a relay it is the combination of a coil form, the magnet wire coating, and the outer wrapping of the relay coil.

A proper insulating system is essential because it separates the control side of a relay (the coil) from the switch side of the relay (the contacts). The switch side of the relay may be used to switch high voltages that are potentially lethal to humans as well as to the circuitry that is connected to the coil side of the relay.

Consequently, when a relay is evaluated for a particular project, it should be evaluated at the maximum ambient temperature it will see in that product. If the insulating system breaks down, it allows electrical current to flow from the switch side of the relay to the control side of the relay. This in turn causes failure--and in some cases can present a safety hazard.

UL understands that time and temperature are the enemies of an insulating system. Just as paint on a house begins to peel with age and exposure to heat, an insulation system begins to break down with age and exposure to heat. Consequently, UL designed and administers a series of tests that assure that this breakdown does not occur even after aging and heating.

UL Document 1446 is concerned with systems of insulating materials. Insulating systems are classified by their ability to withstand elevated temperatures. It is from this document that we derive Class A, Class B, and Class F.

Table 3  
Max. Hot-Spot Temperature of Insulating Systems

System Class	°C	°F
B	130	266
F	155	311
H	180	356
N	200	392
R	220	428
S	240	464

Table 3 is printed directly from the UL document. As it indicates, a Class B relay is rated for a maximum hot spot temperature of 130°C, and Class F relay is rated for a maximum hot spot temperature of 155°C. For a relay, the hot spot temperature is basically the coil temperature. The coil temperature is a result of the self-heating of the coil due to the power dissipation of the coil (coil voltage and current), heating due to the load being carried by the contacts (they get hot too and that leaks over to the coil), and by the ambient temperature of the environment.

At room temperature, most relay coils will not exceed a temperature of 130°C even with full contact load and continuous operation. However, if a particular circuit design calls for the relay to work in a high ambient temperature, or at a coil voltage higher than nominal (or both)--it is possible that the coil temperature might exceed 130°C. Sometimes the designer does not realize this until the product gets to UL--and at that point it is determined that a higher class of insulating system is required. If the Class B (rated up to 130°C) is not sufficient, Class F (rated up to 155°C) would be the next logical choice. Class F relays are proving to be ideal for applications such as:

- Appliance Controls
- Automotive Controls
- Spas and Pool Controls
- Industrial Controls

Plus, as power relays are used more and more in control application, and boards get smaller and smaller allowing less room for heat dissipation--Class B and Class F relays become increasingly attractive.



## ■ WARRANTY

Song Chuan's exclusive warranty is that the Products will be free from defects in materials and workmanship for a period of twelve months from the date of sale by Song Chuan. Song Chuan disclaims all other warranties, express or implied. SONG CHUAN MAKES NO WARRANTY OR REPRESENTATION, EXPRESSED OR IMPLIED, ABOUT NON-INFRINGEMENT, MERCHANTABILITY OR FITNESS FOR A PARTICULAR PURPOSE OF THE PRODUCTS. BY PLACING A PURCHASE ORDER WITH SONG CHUAN OR ITS DISTRIBUTORS, THE CUSTOMER ACKNOWLEDGES THAT THEY ALONE HAVE DETERMINED THAT THE PRODUCTS WILL SUITABLY MEET THE REQUIREMENTS OF THEIR INTENDED USE.

Song Chuan further disclaims all warranties and responsibility of any type of claims or expenses based on infringement by the Products or otherwise of any intellectual property right. Song Chuan's sole obligation hereunder shall be, at Song Chuan's election, to (i) replace (in the form of originally shipped product with the customer responsible for labor charges for removal and or replacement thereof) the non-complying product (ii) repair the non-complying product, or (iii) repay or credit the customer an amount equal to the purchase price on the non-complying product; provided that in no event shall Song Chuan be responsible for warranty, repair, indemnity or any other claims or expenses regarding the products unless Song Chuan's analysis confirms that the product were properly handled, stored, installed, and maintained and not subject to contamination, abuse, misuse, or inappropriate modification. Song Chuan must approve return of any products by the customer in writing before shipment. Song Chuan Group Companies shall not be liable for the suitability or unsuitability or the results from the use of products in combination with any electrical or electronic components, circuits, system assemblies or any other materials or substances or environments. Any advice, recommendations or information given orally or in writing are not to be construed as an amendment or addition to the above warranty.

## ■ LIMITATION ON LIABILITY

SONG CHUAN GROUP COMPANIES SHALL NOT BE LIABLE FOR SPECIAL, INDIRECT, INCIDENTAL OR

CONSEQUENTIAL DAMAGES, LOSS OF PROFITS OR PRODUCTION IN ANY WAY CONNECTED WITH THE PRODUCTS, WHETHER SUCH CLAIM IS BASED IN CONTRACT, WARRANTY, NEGLIGENCE OR STRICT LIABILITY. Further, in no event shall liability of Song Chuan Group Companies exceed the individual price of the product on which liability is asserted.



### »» Features

- Compact size miniature PCB relays.
- Special design of high performance for motor control of wiper and sunroof, and window lift control.
- High rating 20A with maximum switching current up to 30A.
- High temperature endurance up to 125°C.
- IR-Reflow process compatible (special version).
- Complies with RoHS-Directive 2011/65/EU, and ELV-Directive 2000/53/EC.

### »» Type List

Terminal style	Contact form	Designation (provided with)		
		Flux tight	Sealed type	Sealed type washable
PCB terminal	1A (SPNO)	102-1AH-C	102-1AH-V	102-1AH-S
	1C (SPDT)	102-1CH-C	102-1CH-V	102-1CH-S

### »» Ordering Information

102 - 1A H - C   
 1 2 3 4 5

- |                                    |   |
|------------------------------------|---|
| 1. 102 -- Basic series designation | 4. C -- Flux tight  |
| 2. 1A -- Single pole normally open | V -- Sealed type  |
| 1C -- Single pole double throw     | S -- Sealed type washable   |
| 3. H -- Contact material AgSnO     | 5. <input type="checkbox"/> -- Coil voltage (please refer to the coil rating data for the availability) |

### »» Contact Rating

Resistive load	NO/NC : 20A/10A 14VDC
Motor load	Inrush 30A, steady state 10A 14VDC ; 750K ops.
	Motor Lock : 20A 14VDC ; 200K ops.

### »» Coil Rating (DC)

Rated voltage (V)	Rated current ±10 % at 23°C (mA)	Coil resistance ±10 % at 23°C (Ω)	Max. continuous voltage at 85°C <sup>(1)</sup>	Pick up voltage(Max.) at 23°C	Drop out voltage(Min.) at 23°C	Power consumption at rated voltage
6	107	56	125 % of rated voltage	60 % of rated voltage	5 % of rated voltage	approx. 0.64W
9	70.8	127				
12	53.3	225				
24	26.7	900				

Note:(1)Continuous contact current at 10A.

## »» Specification

Contact material	AgSnO alloy	
Contact voltage drop <sup>(1)</sup>	Typ. 50mV at 10A	
Operate time <sup>(1)</sup>	10 ms Max.	
Release time <sup>(1)</sup>	5 ms Max.	
Insulation resistance <sup>(1)</sup>	100MΩ Min. (DC 500V)	
Dielectric strength <sup>(1)</sup>	Between open contact	: AC 500V , 50/60Hz 1 min.
	Between contact and coil	: AC 500V , 50/60Hz 1 min.
Vibration resistance	Operating extremes	10~500Hz , 4.4G
	Damage limits	10~500Hz , 4.4G
Shock resistance	Operating extremes	10G
	Damage limits	100G
Life expectancy	Mechanical	10,000,000 operations (frequency 18,000 operations/hr)
	Electrical	100,000 operations (frequency 360 operations/hr)
Operating ambient temperature	-40~+125°C (no freezing)	
Weight	Approx. 4 g	

Note : (1) Initial value. Operate and release time excluding contact bounce.

## »» Outline Dimensions

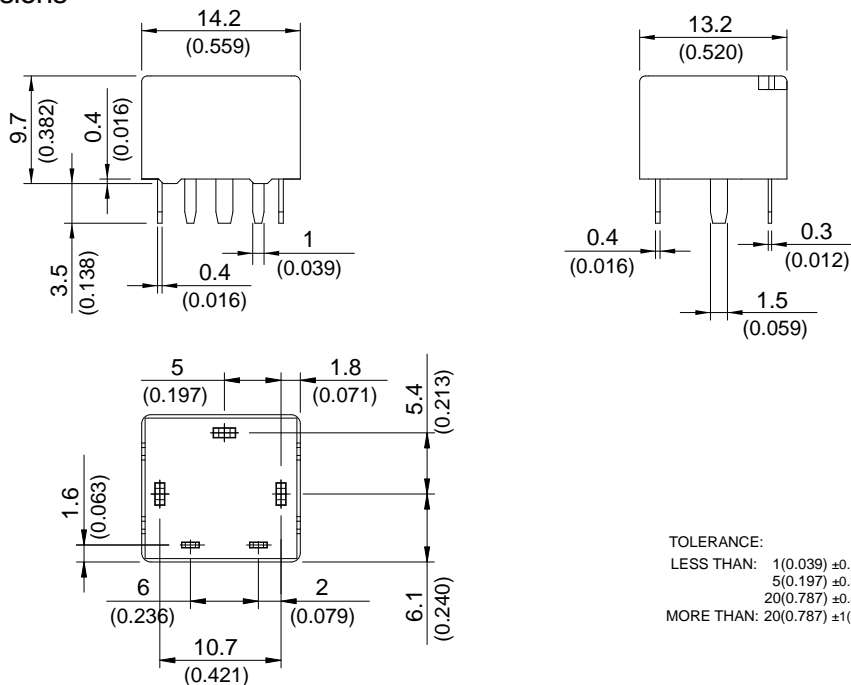

## »» Wiring Diagram

BOTTOM VIEW

1C

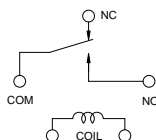

1A

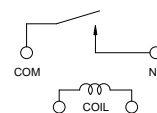

»» PC Board Layout  
BOTTOM VIEW

1C

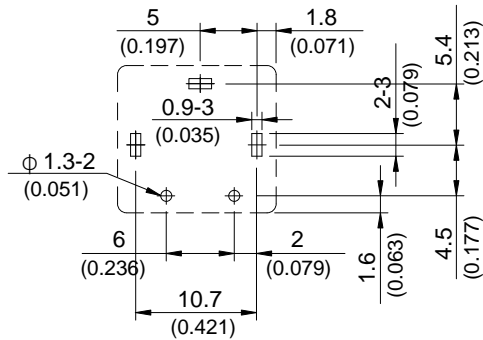

1A

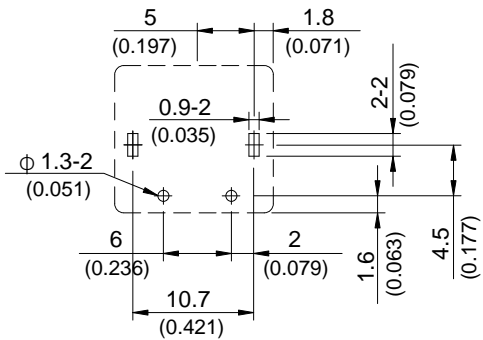

»» Engineering Data

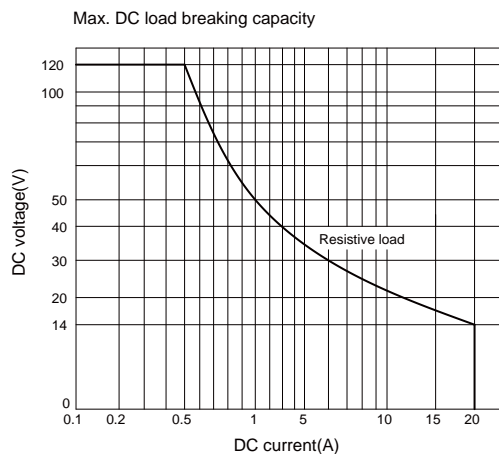
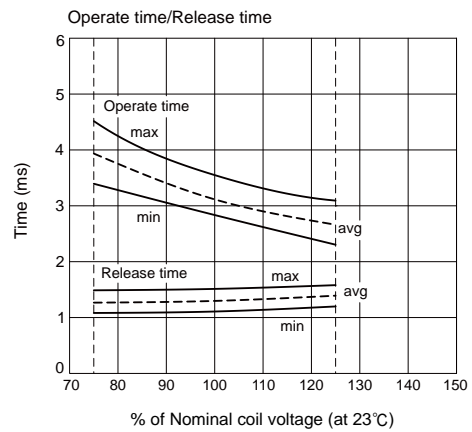
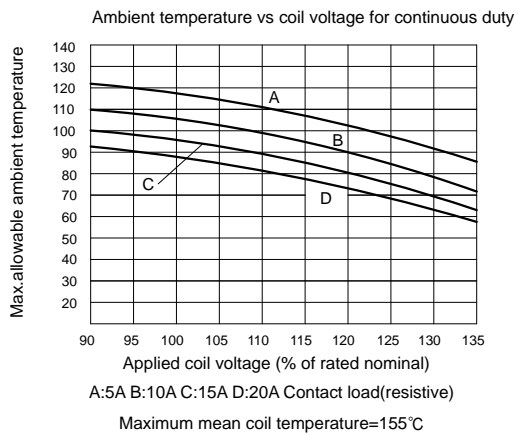
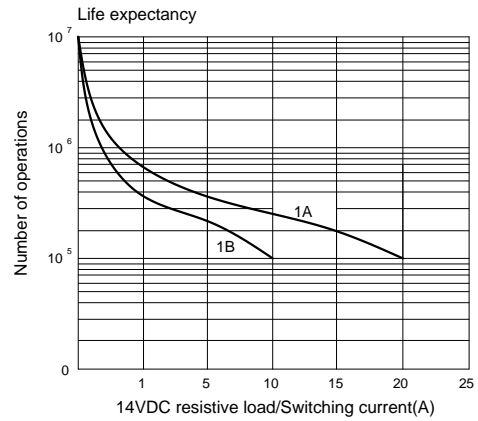
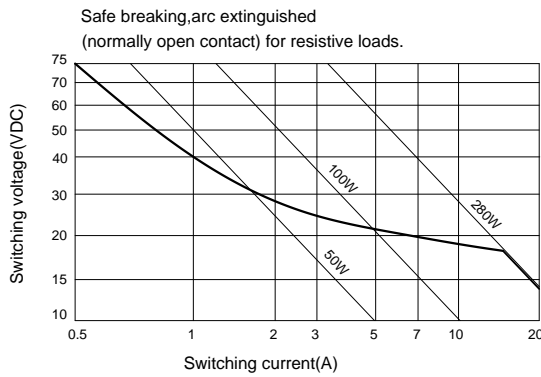



### »» Features

- Smallest and slim type PCB Automotive relay.
- High rating 20A with maximum switching current up to 30A.
- High Temperature withstand up to 125°C.
- Single or twin relays are both available.
- Complies with RoHS-Directive 2011/65/EU, and ELV-Directive 2000/53/EC.

### »» Type List

Terminal style	Contact form	Designation (provided with)		
		Flux tight	Sealed type	Sealed type washable
PCB terminal	1A (SPNO)	103-1AH-C	103-1AH-V	103-1AH-S
	1A (SPNO) x2	103T-1AH-C	103T-1AH-V	103T-1AH-S
	1C (SPDT)	103-1CH-C	103-1CH-V	103-1CH-S
	1C (SPDT) x2	103T-1CH-C	103T-1CH-V	103T-1CH-S

### »» Ordering Information

103        -    1A    H    -    C      
 1        2        3        4        5        6

- |  |   |
|--|---|
| <p>1. 103 -- Basic series designation</p> <p>2. Blank -- Single relay<br/>T -- Twin relay</p> <p>3. 1A -- Single pole normally open<br/>1C -- Single pole double throw</p> | <p>4. H -- Contact material AgSnO</p> <p>5. C -- Flux tight<br/>V -- Sealed type<br/>S -- Sealed type washable</p> <p>6. <input type="checkbox"/> -- Coil voltage (please refer to the coil rating data for the availability)</p> |
|--|---|

### »» Contact Rating

Resistive load	NO/NC : 20A/10A 14VDC
Motor load	Inrush 30A, steady state 10A 14VDC ; 750K ops.
	Motor Lock : 20A 14VDC ; 200K ops.

### »» Coil Rating (DC)

Rated voltage (V)	Rated current ±10 % at 23°C (mA)	Coil resistance ±10 % at 23°C (Ω)	Max. continuous voltage at 85°C	Pick up voltage(Max.) at 23°C	Drop out voltage(Min.) at 23°C	Power consumption at rated voltage
6	107	56	125 % of rated voltage	60 % of rated voltage	5 % of rated voltage	approx. 0.64W
9	70.8	127				
12	53.3	225				
24	26.7	900				

## &gt;&gt;&gt; Specification

Contact material	AgSnO alloy	
Contact voltage drop <sup>(1)</sup>	Typ. 50mV at 10A	
Operate time <sup>(1)</sup>	10 ms Max.	
Release time <sup>(1)</sup>	5 ms Max.	
Insulation resistance <sup>(1)</sup>	100 MΩ Min. (DC 500V)	
Dielectric strength <sup>(1)</sup>	Between open contact	: AC 500V , 50/60Hz 1 min.
	Between contact and coil	: AC 500V , 50/60Hz 1 min.
Vibration resistance	Operating extremes	10~500Hz , 4.4G
	Damage limits	10~500Hz , 4.4G
Shock resistance	Operating extremes	10G
	Damage limits	100G
Life expectancy	Mechanical	10,000,000 operations (frequency 18,000 operations/hr)
	Electrical	100,000 operations (frequency 360 operations/hr)
Operating ambient temperature	-40~+125°C (no freezing)	
Weight	Approx. 4 g	

Note : (1) Initial value. Operate and release time excluding contact bounce.

## &gt;&gt;&gt; Outline Dimensions

## ◆103

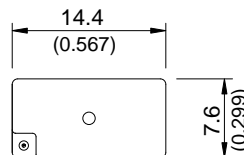

## ◆103T

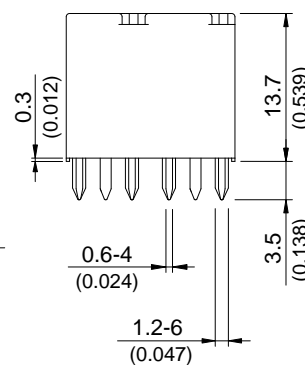
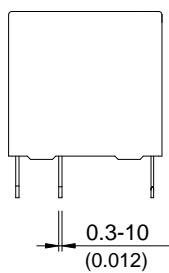
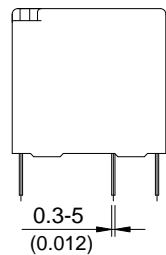
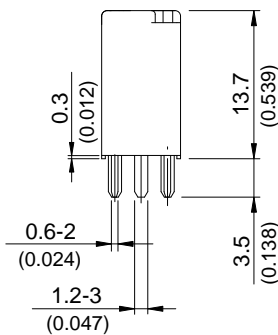
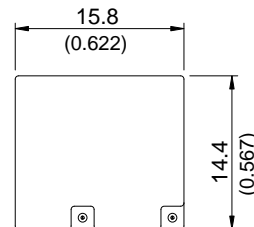
 TOLERANCE:  
 LESS THAN: 1(0.039) ±0.1(0.004)  
 5(0.197) ±0.3(0.012)  
 20(0.787) ±0.5(0.020)  
 MORE THAN: 20(0.787) ±1(0.039)

## &gt;&gt;&gt; Wiring Diagram

BOTTOM VIEW

## ◆103

1A



1C

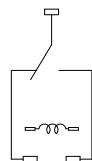

## ◆103T

1A



1C

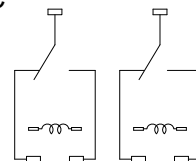

## PC Board Layout

BOTTOM VIEW

### ◆ 103

1A

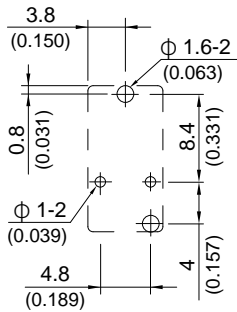

1C

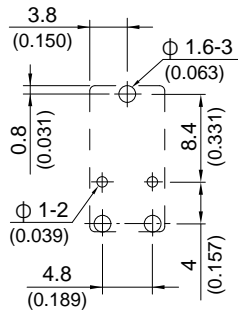

### ◆ 103T

1A

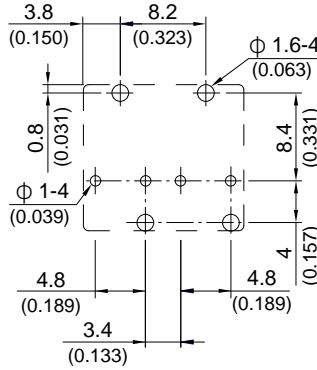

1C

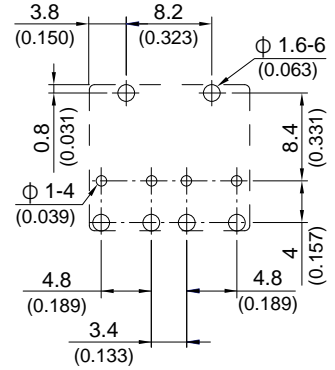

## Engineering Data

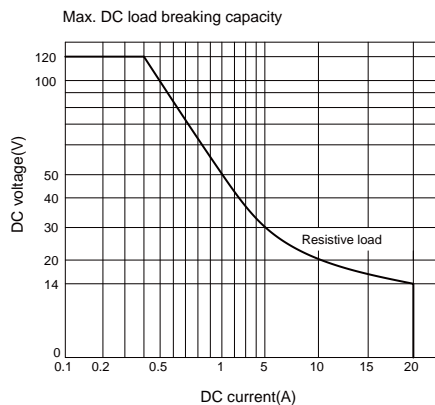
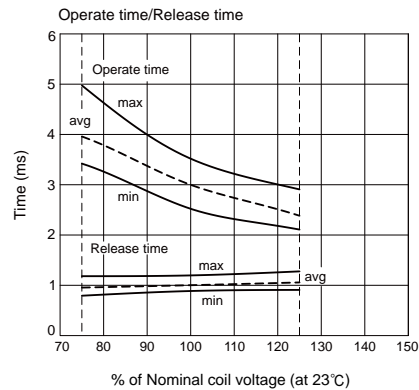
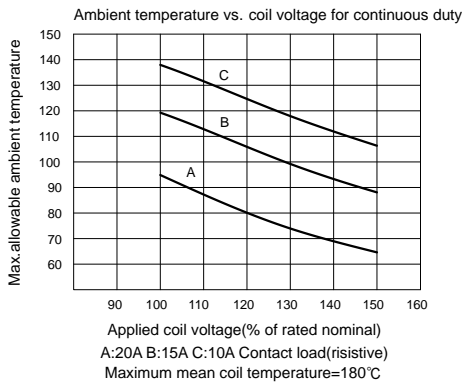
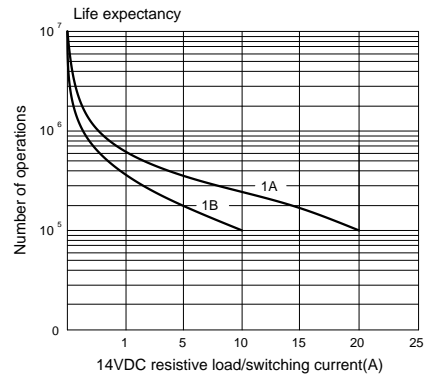
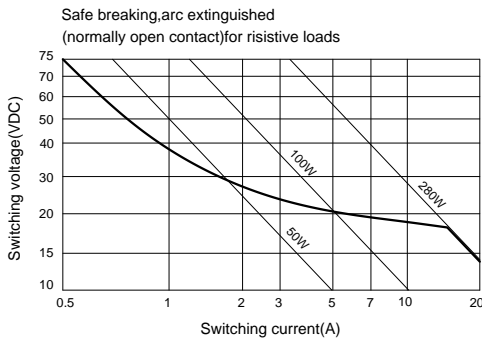



### »» Features

- Low Profile Micro ISO automotive relay.
- SPNO contact configuration.
- Switches up to 25A resistive load, 100,000 ops., 23°C.
- Operating ambient temperature -40°C to 105°C.
- Optional resistor or diode for coil transient suppression.
- Complies with RoHS-Directive 2011/65/EU and ELV-Directive 2000/53/EC.

### »» Type List

Terminal style	Contact form	Designation (provided with)	Enclosure style		
			Dust cover	Flux tight	Sealed type
Micro ISO Footprint	1A (SPNO)	-----	108-1AH-D	108-1AH-C	108-1AH-V
		Resistor	108-1AH-D-R1	108-1AH-C-R1	108-1AH-V-R1
		Diode	108-1AH-D-D1	108-1AH-C-D1	108-1AH-V-D1

### »» Ordering Information

108 - 1A H - D -    
 1 2 3 4 5 6

- |                                    |   |
|------------------------------------|---|
| 1. 108 -- Basic series designation | 5. Blank -- Standard type   |
| 2. 1A -- Single pole normally open | R1 -- Coil parallel with 1/2W resistor for 12V 1.1K Ω   |
| 3. H -- Contact material AgSnO     | D1 -- Coil parallel with diode 1N4007 the diode anode on #2 terminal                                    |
| 4. D -- Dust cover                 |   |
| C -- Flux tight                    | 6. <input type="checkbox"/> -- Coil voltage (please refer to the coil rating data for the availability) |
| V -- Sealed type                   |   |

### »» Contact Rating

Resistive load	NO : 25A 14VDC ; ON 2s / OFF 2s ; 100K ops.
----------------	---

### »» Coil Rating (DC)

Rated voltage (V)	Rated current ±10 % at 23°C (mA)	Coil resistance ±10 % at 23°C (Ω)	Max. continuous voltage at 80°C <sup>(1)</sup>	Pick up voltage(Max.) at 23°C	Drop out voltage(Min.) at 23°C	Power consumption at rated voltage
12	66	180	16V	8.0V	0.6V	approx. 0.8W

Note : (1) With 20A contact current

### »» Specification

Contact material	AgSnO alloy
Contact voltage drop <sup>(1)</sup>	Typ. 50mV at 10A
Operate time <sup>(1)</sup>	10 ms Max.
Release time <sup>(1)</sup>	10 ms Max.
Insulation resistance <sup>(1)</sup>	20 MΩ Min. (DC 500V)

Dielectric strength <sup>(1)</sup>	Between open contact	: AC 500V, 50/60Hz 1 min.
	Between contact and coil	: AC 500V, 50/60Hz 1 min.
Vibration resistance	Operating extremes	10~500Hz , 5.0G
	Damage limits	10~500Hz , 5.0G
Shock resistance	Operating extremes	10G
	Damage limits	100G
Life expectancy	Mechanical	1,000,000 operations (frequency 18,000 operations/hr)
Operating ambient temperature	-40 ~ +105°C (no freezing)	
Weight	Approx. 15 g	

Note : (1) Initial value. Operate and release time excluding contact bounce.

### »» Outline Dimensions

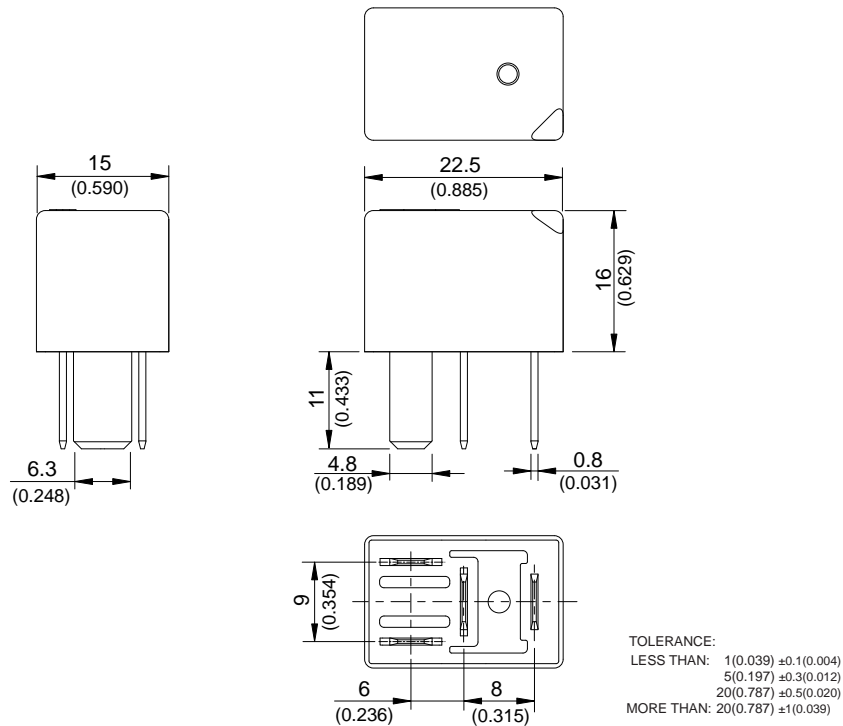

### »» Wiring Diagram

BOTTOM VIEW

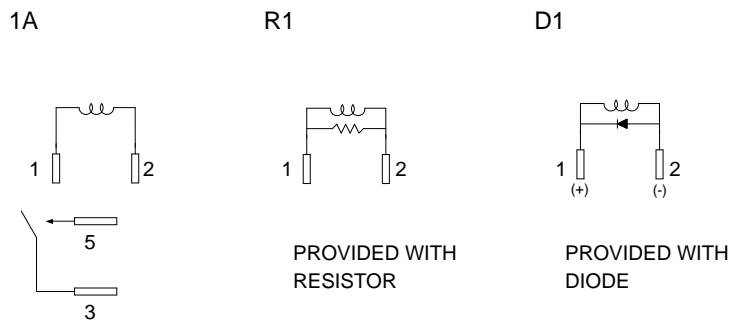



### »» Features

- Micro 280 automotive relay.
- SPNO & SPDT contact configurations.
- NO contacts switch 35A resistive load, NC contacts switch 20A resistive load, 100,000 ops., 23°C.
- Operating ambient temperature -40°C to 125°C.
- Optional resistor or diode for coil transient suppression.
- Complies with RoHS-Directive 2011/65/EU and ELV-Directive 2000/53/EC.

### »» Type List

Terminal style	Contact form	Designation (provided with)	Enclosure style		
			Dust cover	Flux tight	Sealed type washable
Socket terminal	1A (SPNO)	-----	301-1A-D	301-1A-C	301-1A-S
		Resistor	301-1A-D-R1	301-1A-C-R1	301-1A-S-R1
		Diode	301-1A-D-D1	301-1A-C-D1	301-1A-S-D1
	1C (SPDT)	-----	301-1C-D	301-1C-C	301-1C-S
		Resistor	301-1C-D-R1	301-1C-C-R1	301-1C-S-R1
		Diode	301-1C-D-D1	301-1C-C-D1	301-1C-S-D1

### »» Ordering Information

301 - 1A - D -    
 1        2        3        4        5

1. 301 -- Basic series designation
2. 1A -- Single pole normally open  
1C -- Single pole double throw
3. D -- Dust cover  
C -- Flux tight  
S -- Sealed type washable
4. Blank -- Standard type  
R1 -- Coil parallel with 1/2W resistor for 6V 180Ω, 12V 680Ω, 24V 2700Ω  
D1 -- Coil parallel with diode 1N4007 the diode anode on # 85 terminal
5.  -- Coil voltage (please refer to the coil rating data for the availability)

### »» Contact Rating

Resistive load	1A	1C
	35A 14VDC 15A 28VDC	NO: 35A 14VDC, 15A 28VDC NC: 20A 14VDC, 10A 28VDC

### »» Coil Rating (DC)

Rated voltage (V)	Rated current ±10 % at 23°C (mA)	Coil resistance ±10 % at 23°C (Ω)	Max. continuous voltage at 85°C	Pick up voltage(Max.) at 23°C	Drop out voltage(Min.) at 23°C	Power consumption at rated voltage
6	187.5	32	133 % of rated voltage	60 % of rated voltage	10 % of rated voltage	approx. 1.2W
12	97.5	123				
24	49.6	483				

## »» Specification

Contact material	AgSnO alloy	
Contact voltage drop <sup>(1)</sup>	Typ. 40mV at 10A	
Operate time <sup>(1)</sup>	10ms Max.	
Release time <sup>(1)</sup>	10ms Max.	
Insulation resistance <sup>(1)</sup>	20MΩ Min. (DC 500V)	
Dielectric strength <sup>(1)</sup>	Between open contact	: AC 500V , 50/60Hz 1 min.
	Between contact and coil	: AC 500V , 50/60Hz 1 min.
Vibration resistance	Operating extremes	10~500Hz , 5.0G
	Damage limits	10~500Hz , 5.0G
Shock resistance	Operating extremes	10G
	Damage limits	100G
Life expectancy	Mechanical	10,000,000 operations (frequency 18,000 operations/hr)
	Electrical	100,000 operations (frequency 1,800 operations/hr)
Operating ambient temperature	-40~+125°C (no freezing)	
Weight	Approx. 20 g	

Note : (1) Initial value. Operate and release time excluding contact bounce.

## »» Outline Dimensions

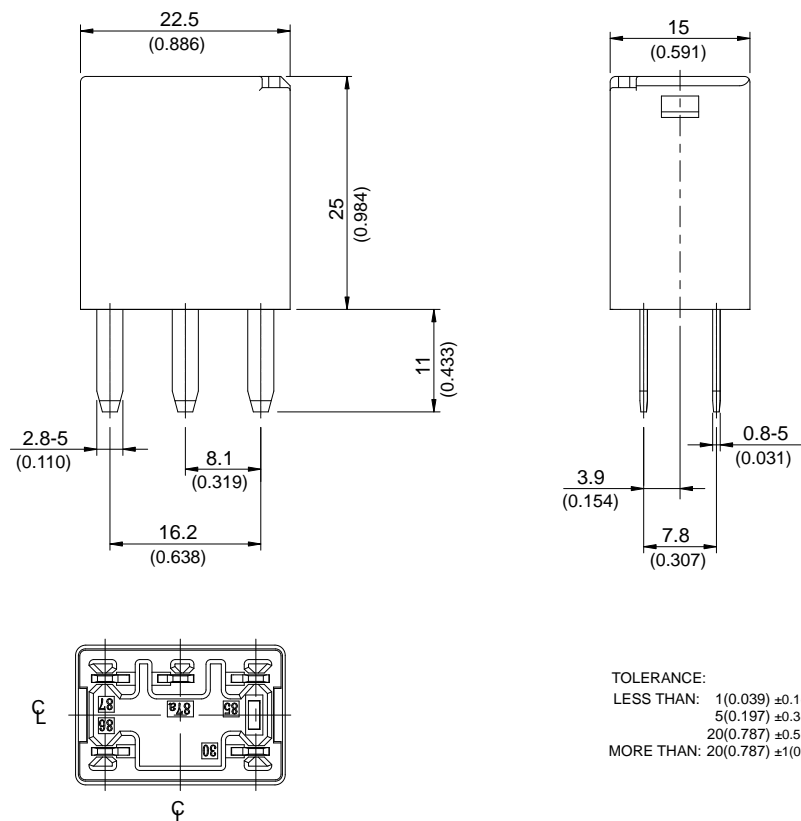

## »» Wiring Diagram BOTTOM VIEW

1A

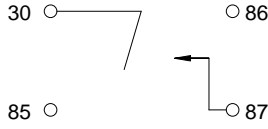

1C

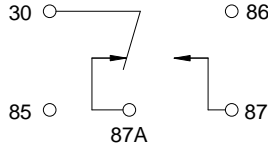

R1

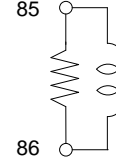

D1

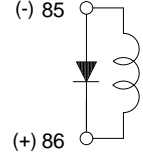

## »» Engineering Data

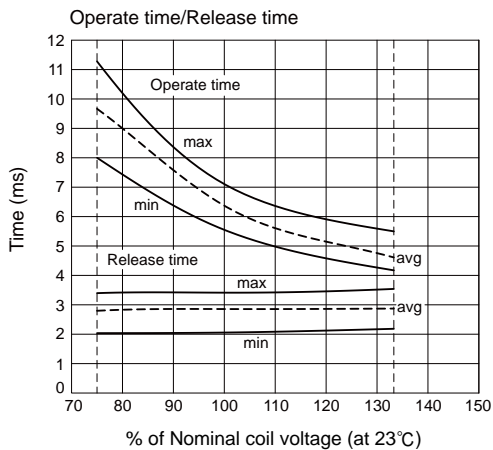
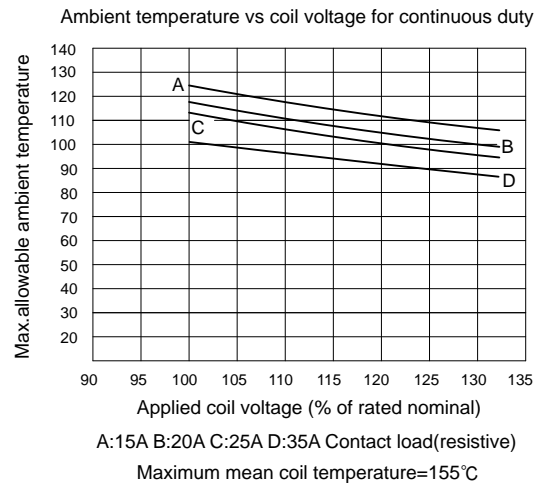
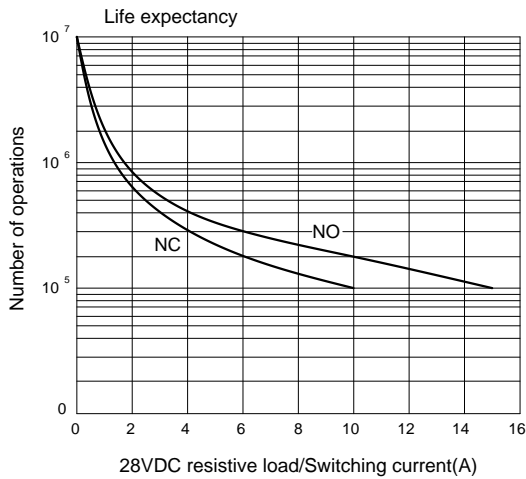
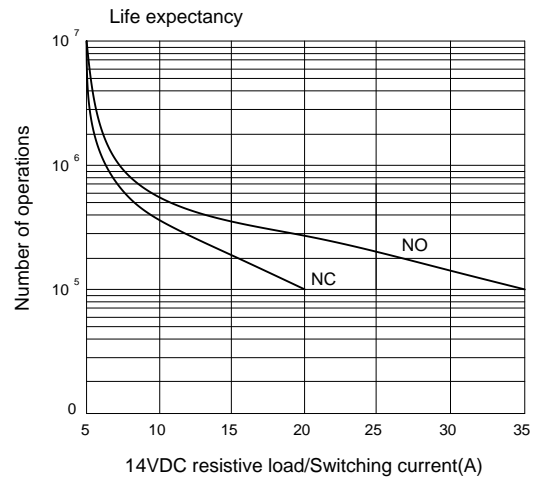

**»» Features**

- Ultra Micro 280 automotive relay.
- SPNO contact configuration.
- Switch up to 20A resistive load, 100,000 ops., 23°C.
- Operating ambient temperature -40°C to 125°C.
- Optional resistor or diode for coil transient suppression.
- Complies with RoHS-Directive 2011/65/EU and ELV-Directive 2000/53/EC.

**»» Type List**

Terminal style	Contact form	Designation (provided with)	Enclosure style	
			Flux tight	Sealed type washable
Socket terminal	1A (SPNO)	-----	303-1AH-C	303-1AH-S
		Resistor	303-1AH-C-R1	303-1AH-S-R1
		Diode	303-1AH-C-D1	303-1AH-S-D1

**»» Ordering Information**

303 - 1A H - C -    
 1 2 3 4 5 6

- |   |   |
|---|---|
| 1. 303 -- Basic series designation              | 5. Blank -- Standard type   |
| 2. 1A -- Single pole normally open              | R1 -- Coil parallel with 1/2W resistor for 12V 1.1KΩ, 24V 4.3KΩ   |
| 3. H -- Contact material AgSnO                  | D1 -- Coil parallel with diode 1N4007 the diode anode on # 85 terminal                                  |
| 4. C -- Flux tight<br>S -- Sealed type washable | 6. <input type="checkbox"/> -- Coil voltage (please refer to the coil rating data for the availability) |

**»» Contact Rating**

Resistive load	20A 14VDC, 10A 28VDC ; ON 2s / OFF 2s ; 100K ops.
Motor load	16A 14VDC, Inrush 80A ; ON 2s / OFF 5s ; -30~+80°C ; 300K ops.
Lamp load	16A 14VDC, Inrush 80A ; ON 3s / OFF 3s ; -30~+100°C ; 100K ops.

**»» Coil Rating (DC)**

Rated Voltage (V)	Rated current ±10 % at 23°C (mA)	Coil resistance ±10 % at 23°C (Ω)	Max continuous voltage at 85°C	Pick up voltage(Max.) at 23°C	Drop out voltage(Min.) at 23°C	Power consumption at rated voltage
12	80	150	133 % of rated voltage	60 % of rated voltage	8 % of rated voltage	approx. 0.96W
24	40	600		60 % of rated voltage	8 % of rated voltage	

## »» Specification

Contact material	AgSnO alloy	
Contact voltage drop <sup>(1)</sup>	Typ. 50mV at 10A	
Operate time <sup>(1)</sup>	10 ms Max.	
Release time <sup>(1)</sup>	10 ms Max.	
Insulation resistance <sup>(1)</sup>	20 MΩ Min. (DC 500V)	
Dielectric strength <sup>(1)</sup>	Between open contact	: AC 500V, 50/60Hz 1 min.
	Between contact and coil	: AC 500V, 50/60Hz 1 min.
Vibration resistance	Operating extremes	10~500Hz , 5.0G
	Damage limits	10~500Hz , 5.0G
Shock resistance	Operating extremes	10G
	Damage limits	100G
Life expectancy	Mechanical	10,000,000 operations (frequency 18,000 operations/hr)
Operating ambient temperature	-40 ~ +125°C (no freezing)	
Weight	Approx. 20 g	

Note : (1) Initial value. Operate and release time excluding contact bounce.

## »» Outline Dimensions

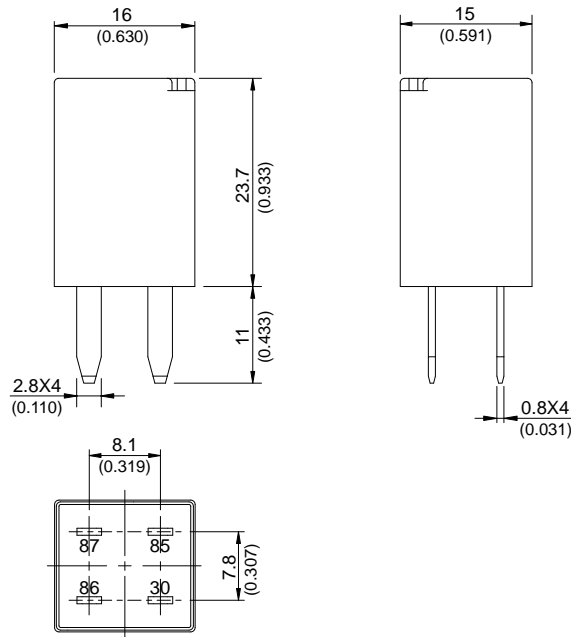

## »» Wiring Diagram

BOTTOM VIEW

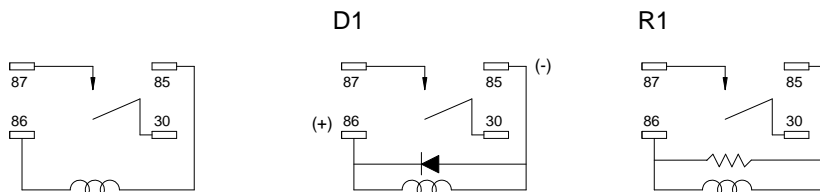

»» Engineering Data

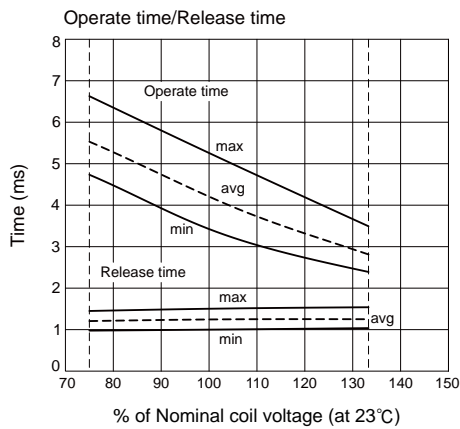
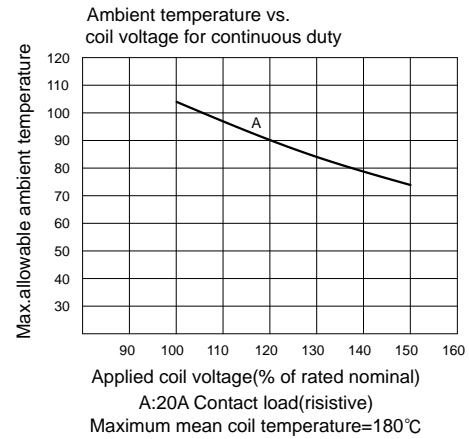
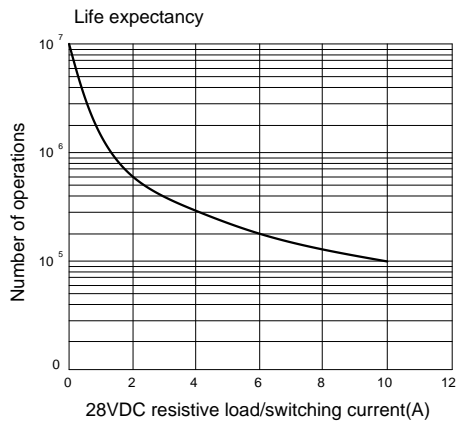
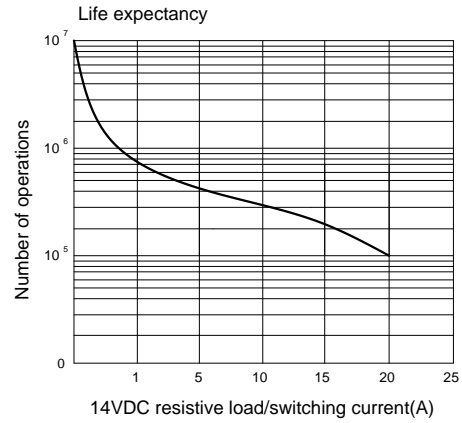
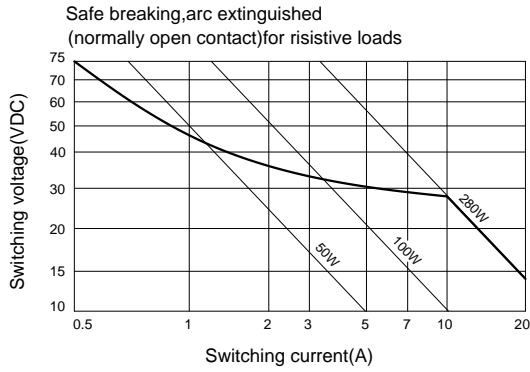



### »» Features

- 200A high power automotive relay.
- SPNO contact configuration.
- Switches up to 200A resistive load, 50,000 ops., 23°C.
- Optional resistor or diode for coil transient suppression.
- Complies with RoHS-Directive 2011/65/EU and ELV-Directive 2000/53/EC.

### »» Type List

Contact form	Enclosure style
	Flanged cover (Sealed type)
1A (SPNO)	409-1AH-V1

### »» Ordering Information

409 - 1A H - V1 -     
 1 2 3 4 5 6 7

- |  |  |
|--|--|
| 1. 409 -- Basic series designation     | 6. Blank -- Standard type  |
| 2. 1A -- Single pole normally open     | 001 -- Coil parallel with diode 1N4007<br>the diode anode on # 2 terminal                                  |
| 3. H -- Contact material Ag alloy      | 002 -- Coil parallel with diode 1N4007<br>the diode cathode on # 2 terminal                                |
| 4. V1 -- Flanged cover (sealed type)   | 7. <input type="checkbox"/> -- Coil voltage (please refer to the<br>coil rating data for the availability) |
| 5. Blank -- Standard type              |  |
| R1 -- Coil parallel with 1/2W resistor |  |

### »» Contact Rating

Resistive load	200A 24VDC ; ON 1s / OFF 3s ; 50,000 ops.
----------------	---

### »» Coil Rating (DC)

Rated voltage (V)	Rated current ±10 % at 23°C (mA)	Coil resistance ±10 % at 23°C (Ω)	Max. continuous voltage at 75°C	Pick up voltage(Max.) at 23°C	Drop out voltage(Min.) at 23°C	Power consumption at rated voltage
24	200	120	28V	16V	1V	approx. 4.8W

### »» Specification

Contact material	Ag alloy	
Contact voltage drop <sup>(1)</sup>	Typ. 200mV at 200A	
Operate time <sup>(1)</sup>	50 ms Max.	
Release time <sup>(1)</sup>	50 ms Max.	
Insulation resistance <sup>(1)</sup>	20 MΩ Min. (DC 500V)	
Dielectric strength <sup>(1)</sup>	Between open contact	: AC 1000V, 50/60Hz 1 min.
	Between contact and coil	: AC 1000V, 50/60Hz 1 min.
Vibration resistance	Operating extremes	10~500Hz , 5.0G
	Damage limits	10~500Hz , 5.0G

Shock resistance	Operating extremes	10G
	Damage limits	100G
Life expectancy	Mechanical	1,000,000 operations (frequency 18,000 operations/hr)
Recommended securing torque on load side terminal	9~12 N-m	
Operating ambient temperature	-40 ~ +75°C (no freezing)	
Weight	Approx. 330g	

Note : (1) Initial value. Operate and release time excluding contact bounce.

### »» Outline Dimensions

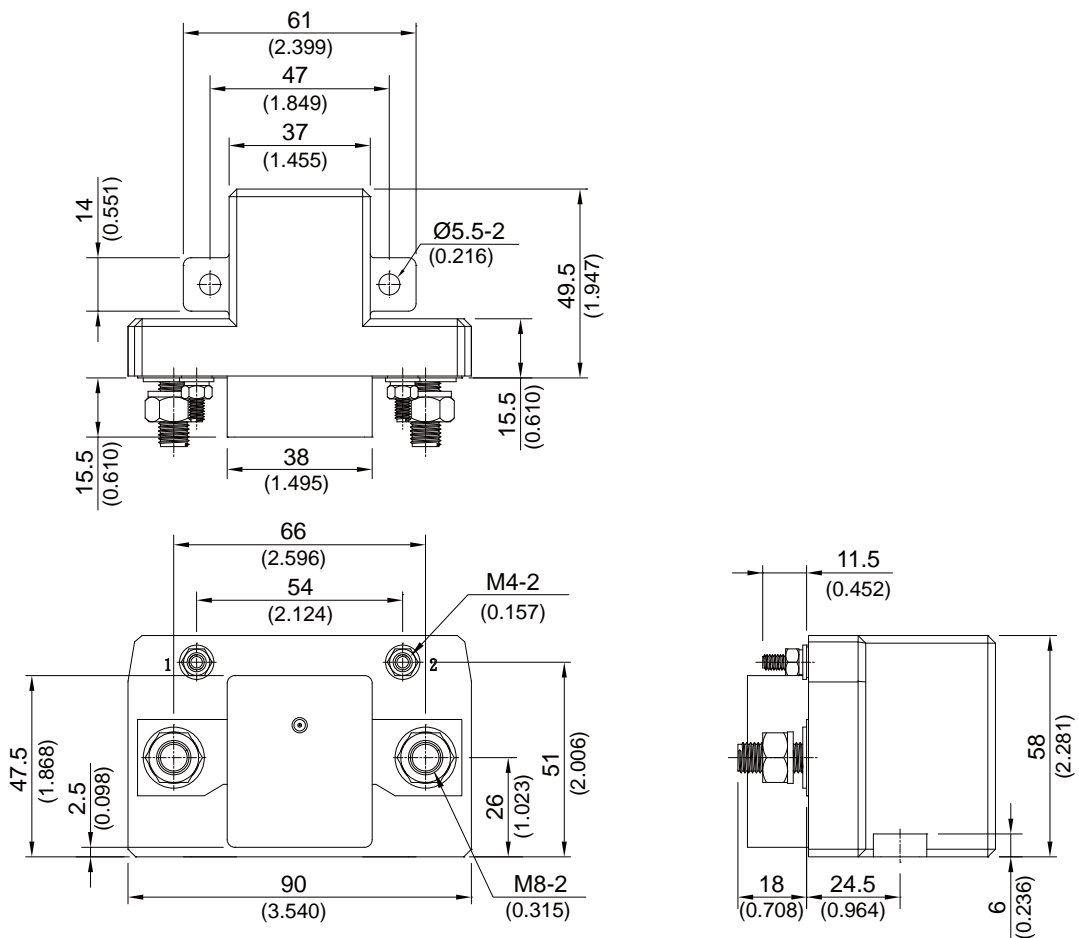

TOLERANCE:  
 LESS THAN: 1(0.039) ±0.1(0.004)  
 5(0.197) ±0.3(0.012)  
 20(0.787) ±0.5(0.020)  
 MORE THAN: 20(0.787) ±1(0.039)

### »» Wiring Diagram

BOTTOM VIEW

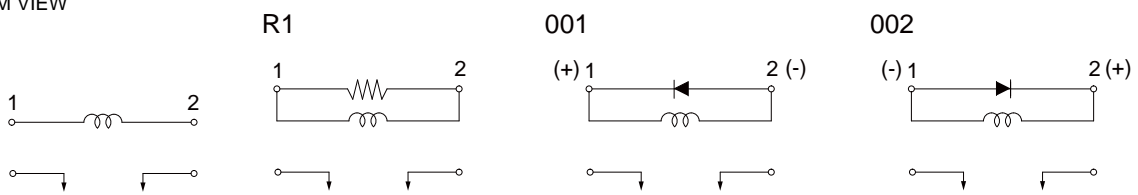



### »» Features

- High current micro ISO automotive relay.
- SPNO contact configuration.
- Switches up to 35A resistive load, 100,000 ops.
- Dust cover, flux-free type and sealed type are available.
- Optional resistor or diode for coil transient suppression.
- Complies with RoHS-Directive 2011/65/EU and ELV-Directive 2000/53/EC.

### »» Type List

Terminal style	Contact form	Designation (provided with)	Enclosure style		
			Dust cover	Flux tight	Sealed type washable
Socket terminal	1A (SPNO)	-----	611-1AH-D	611-1AH-C	611-1AH-S
		Resistor	611-1AH-D-R1	611-1AH-C-R1	611-1AH-S-R1
		Diode	611-1AH-D-D1	611-1AH-C-D1	611-1AH-S-D1

### »» Ordering Information

611 - 1A H - D -    
 1 2 3 4 5 6

- |   |  |
|---|--|
| <p>1. 611 -- Basic series designation</p> <p>2. 1A -- Single pole normally open</p> <p>3. H -- Contact material AgSnO</p> <p>4. D -- Dust cover<br/>         C -- Flux tight<br/>         V -- Sealed type<br/>         S -- Sealed type washable</p> | <p>5. Blank -- Standard type</p> <p>R1 -- Coil parallel with 1/2W resistor for 12V 680Ω</p> <p>D1 -- Coil parallel with diode 1N4007 the diode anode on # 85 terminal</p> <p>6. <input type="checkbox"/> -- Coil voltage (please refer to the coil rating data for the availability)</p> |
|---|--|

### »» Contact Rating

Resistive load	35A 14VDC ; ON 2s / OFF 2s ; -40~+125°C
Motor load	Inrush 80A, steady 33A 14VDC ; ON 3s / OFF 4s ; -40~+125°C
Lamp load	Inrush 150A, steady 30A 14VDC ; ON 3s / OFF 4s ; -40~+125°C

### »» Coil Rating (DC)

Rated voltage (V)	Rated current ±10 % at 23°C (mA)	Coil resistance ±10 % at 23°C (Ω)	Max. continuous voltage at 85°C	Pick up voltage(Max.) at 23°C	Drop out voltage(Min.) at 23°C	Power consumption at rated voltage
12	97.5	123	16V	7.8V	1.2V	approx. 1.2W

## »» Specification

Contact material	AgSnO alloy	
Contact voltage drop <sup>(1)</sup>	Typ. 40mV at 10A	
Operate time <sup>(1)</sup>	10ms Max.	
Release time <sup>(1)</sup>	10ms Max.	
Insulation resistance <sup>(1)</sup>	20MΩ Min. (DC 500V)	
Dielectric strength <sup>(1)</sup>	Between open contact	: AC 500V, 50/60Hz 1 min.
	Between contact and coil	: AC 500V, 50/60Hz 1 min.
Vibration resistance	Operating extremes	10~500Hz , 5.0G
	Damage limits	10~500Hz , 5.0G
Shock resistance	Operating extremes	10G
	Damage limits	100G
Life expectancy	Mechanical	1,000,000 operations (frequency 18,000 operations/hr)
	Electrical	100,000 operations
Operating ambient temperature	-40~+125°C (no freezing)	
Weight	Approx. 20g	

Note : (1) Initial value. Operate and release time excluding contact bounce.

## »» Outline Dimensions

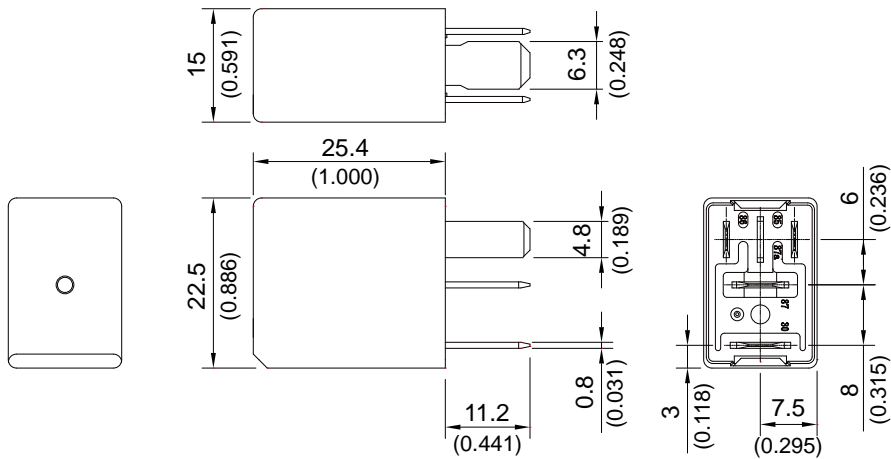

TOLERANCE:  
 LESS THAN: 1(0.039) ±0.1(0.004)  
 5(0.197) ±0.3(0.012)  
 20(0.787) ±0.5(0.020)  
 MORE THAN: 20(0.787) ±1(0.039)

## »» Wiring Diagram

BOTTOM VIEW

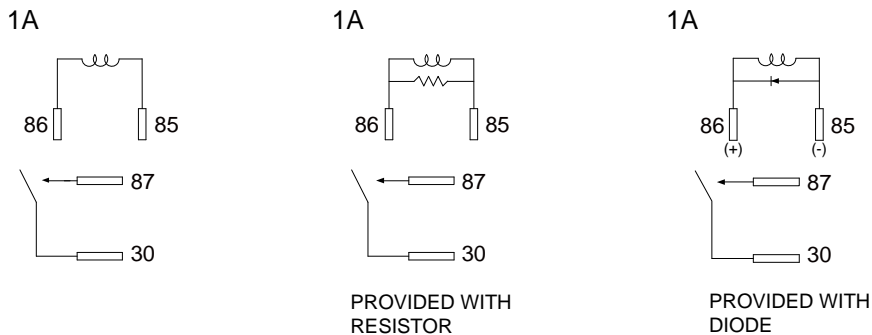

## 804



## »» Features

- Special design of automotive relays 30A/14VDC for Japanese car model.
- Optional to be equipped with diode or resistor.
- Plain cover or flange cover version both available.
- General purpose for air conditioning control, halogen head lamp control, horn control, fog lamp control, etc.
- Complies with RoHS-Directive 2011/65/EU and ELV-Directive 2000/53/EC.

## »» Type List

Terminal style	Contact form	Coil parallel with	Designation (provided with)		
			Dust cover	Sealed type	Mounting ears
Socket terminal	1A (SPNO)	Blank	804-1A-C	804-1A-S	804-1A-C1
		Resistor	804-1A-C-R1	804-1A-S-R1	804-1A-C1-R1
		Resistor	804-1A-C-R2	804-1A-S-R2	804-1A-C1-R2

## »» Ordering Information

804 - 1A - C -    
 1        2        3        4        5

- |   |   |
|---|---|
| <p>1. 804 -- Basic series designation</p> <p>2. 1A -- Single pole normally open</p> <p>3. C -- Dust cover<br/>         C1 -- Mounting ears on cover<br/>         V -- Sealed type<br/>         S -- Sealed type washable</p> <p>4. Blank -- Standard type</p> | <p>R1 -- Coil parallel with 1/2W resistor for 12V 680Ω, 24V 2700Ω</p> <p>R2 -- Coil parallel with 1/2W resistor for 12V 820Ω, 24V 3200Ω</p> <p>D1 -- Coil parallel with diode 1N4007</p> <p>5. <input type="checkbox"/> -- Coil voltage (please refer to the coil rating data for the availability)</p> |
|---|---|

## »» Contact Rating

Resistive load	30A 12VDC ; 15A 24VDC
----------------	-----------------------

## »» Coil Rating (DC)

Rated voltage (V)	Rated current ±10 % at 23°C (mA)	Coil resistance ±10 % at 23°C (Ω)	Max. continuous voltage at 85°C <sup>(1)</sup>	Pick up voltage(Max.) at 23°C	Drop out voltage(Min.) at 23°C	Power consumption at rated voltage
12	120	100	120 % of rated voltage	65 % of rated voltage	10 % of rated voltage	approx. 1.4W
24	60	400		70 % of rated voltage		

Note:(1)Continuous contact current at 10A.

## &gt;&gt;&gt; Specification

Contact material	AgSnO alloy	
Contact voltage drop <sup>(1)</sup>	Typ. 50mV at 10A	
Operate time <sup>(1)</sup>	10ms Max.	
Release time <sup>(1)</sup>	10ms Max.	
Insulation resistance <sup>(1)</sup>	50MΩ Min. (DC 500V)	
Dielectric strength <sup>(1)</sup>	Between open contact	: AC 500V , 50/60Hz 1 min.
	Between contact and coil	: AC 500V , 50/60Hz 1 min.
Vibration resistance	Operating extremes	10~500Hz , 5.0G
	Damage limits	10~500Hz , 5.0G
Shock resistance	Operating extremes	10G
	Damage limits	100G
Life expectancy	Mechanical	5,000,000 operations Min. (frequency 18,000 operations/hr)
	Electrical	100,000 operations Min. (frequency 1,200 operations/hr)
Operating ambient temperature	-30~+85°C (no freezing)	
Weight	Approx. 35 g	

Note : (1) Initial value. Operate and release time excluding contact bounce.

## &gt;&gt;&gt; Outline Dimensions

## ◆804 (C)

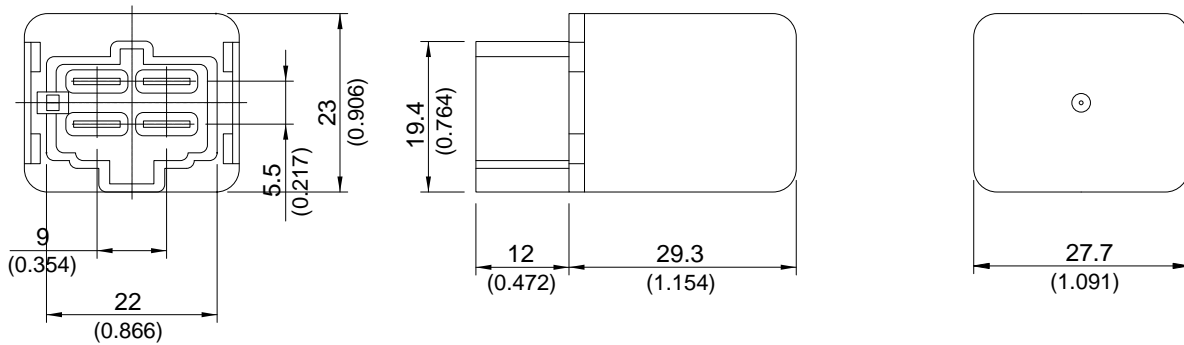

## ◆804 (C1)

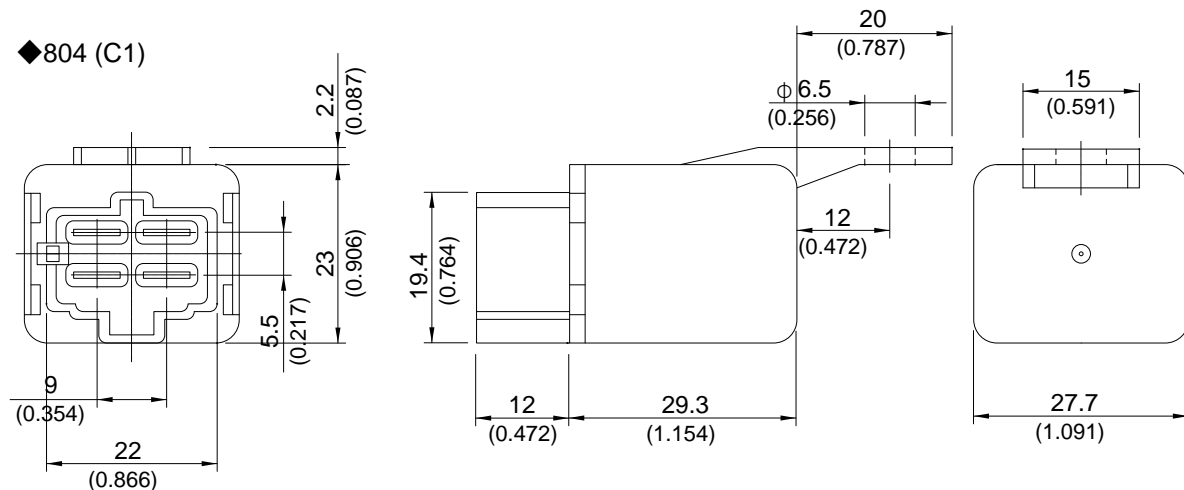

# 804

## ◆ 804 (S)

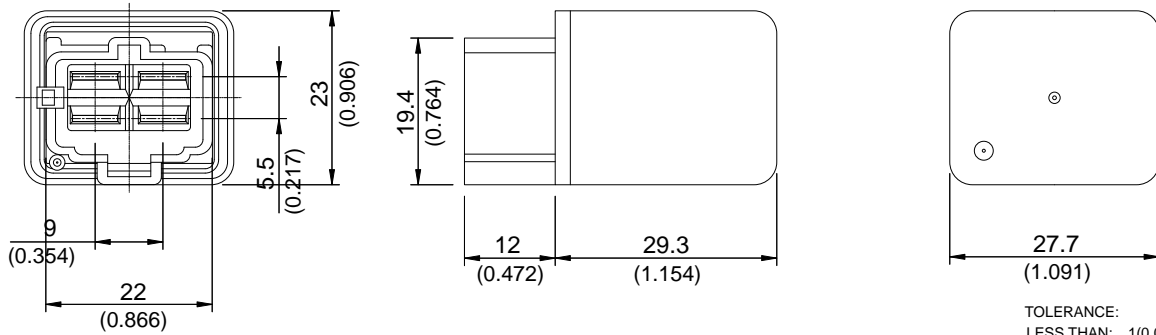

TOLERANCE:  
 LESS THAN: 1(0.039) ±0.1(0.004)  
 5(0.197) ±0.3(0.012)  
 20(0.787) ±0.5(0.020)  
 MORE THAN: 20(0.787) ±1(0.039)

### »» Wiring Diagram

BOTTOM VIEW

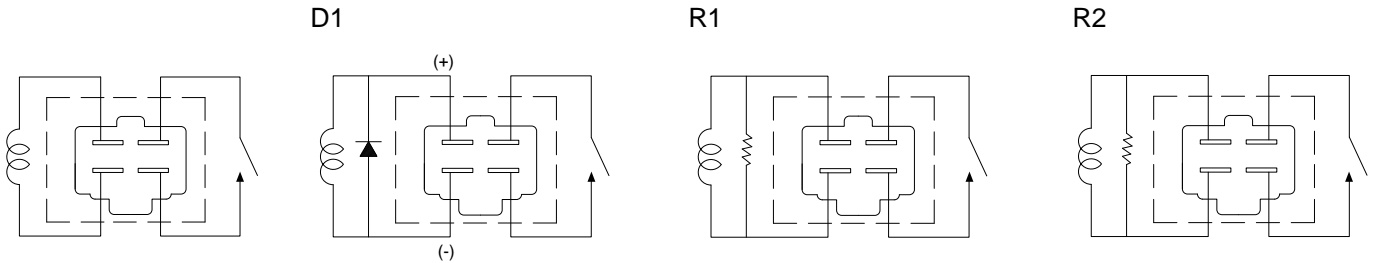

### »» Engineering Data

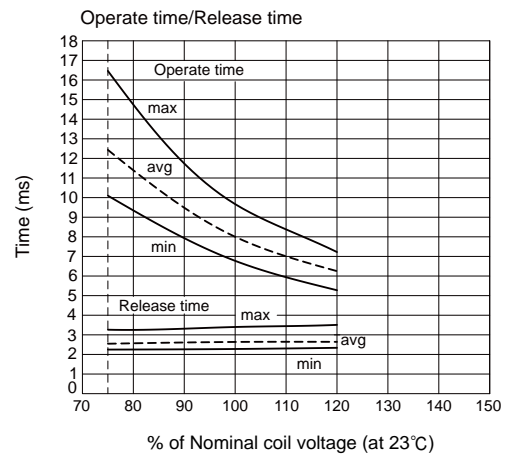
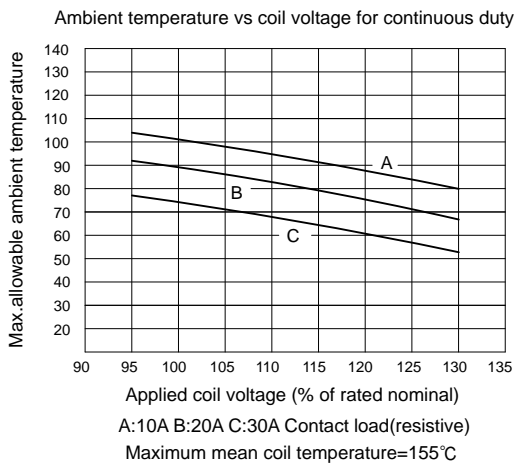
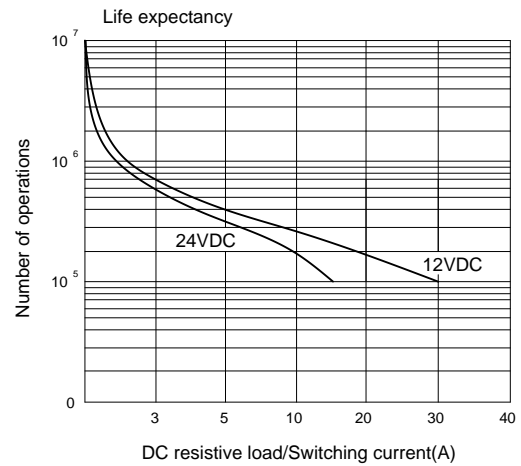
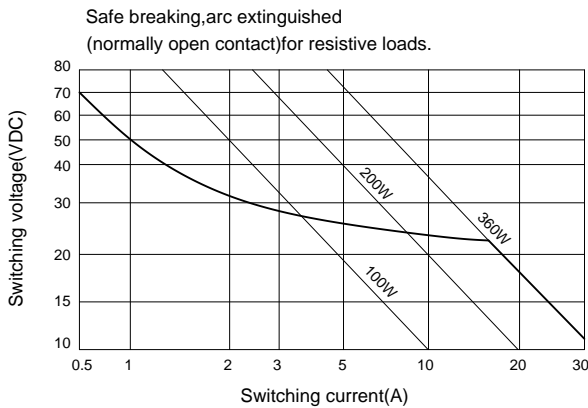



### »» Features

- High performance sugar cube automotive relay.
- Heavy duty suitable for wiper motor control, flashing lamp control, adjustable driver seat motor control, etc.
- Optional for flux-free type or sealed washable type.
- Complies with RoHS-Directive 2011/65/EU, and ELV-Directive 2000/53/EC.

### »» Type List

Terminal style	Contact form	Designation (provided with)		
		Flux tight	Sealed type	Sealed type washable
PCB terminal	1A (SPNO)	812HM-1A-C	812HM-1A-V	812HM-1A-S
	1C (SPDT)	812HM-1C-C	812HM-1C-V	812HM-1C-S

### »» Ordering Information

812      H      M      -      1C      -      C        
 1          2          3          4          5          6

- |   |  |
|---|--|
| 1. 812 -- Basic series designation<br>2. H -- High power type<br>3. M -- Automotive relay<br>4. 1A -- Single pole normally open<br>1C -- Single pole double throw | 5. C -- Flux tight<br>V -- Sealed type<br>S -- Sealed type washable<br>6. <input type="checkbox"/> -- Coil voltage (please refer to the coil rating data for the availability) |
|---|--|

### »» Contact Rating

Resistive load	15A 14VDC	Motor load	5A 14VDC Inrush 25A
----------------	-----------	------------	---------------------

### »» Coil Rating (DC)

Rated voltage (V)	Rated current ±10 % at 23°C (mA)	Coil resistance ±10 % at 23°C (Ω)	Max. continuous voltage at 85°C <sup>(1)</sup>	Pick up voltage(Max.) at 23°C	Drop out voltage(Min.) at 23°C	Power consumption at rated voltage
9	71.4	126	133 % of rated voltage	65 % of rated voltage	5 % of rated voltage	approx. 0.64W
12	53.3	225		rated voltage	rated voltage	
24	26.7	900		rated voltage	rated voltage	

Note : (1) Continuous contact current at 10A.

# 812HM

## »» Specification

Contact material	AgSnO alloy	
Contact voltage drop <sup>(1)</sup>	Typ. 50mV at 10A	
Operate time <sup>(1)</sup>	15ms Max.	
Release time <sup>(1)</sup>	10ms Max.	
Insulation resistance <sup>(1)</sup>	100 MΩ Min. (DC 500V)	
Dielectric strength <sup>(1)</sup>	Between open contact	: AC 500V , 50/60Hz 1 min.
	Between contact and coil	: AC 500V , 50/60Hz 1 min.
Vibration resistance	Operating extremes	10~500Hz , 4.4G
	Damage limits	10~500Hz , 4.4G
Shock resistance	Operating extremes	10G
	Damage limits	100G
Life expectancy	Mechanical	10,000,000 operations (frequency 18,000 operations/hr)
	Electrical	100,000 operations (frequency 1,200 operations/hr)
Operating ambient temperature	-40~+85°C (no freezing)	
Weight	Approx. 10 g	

Note : (1) Initial value. Operate and release time excluding contact bounce.

## »» Outline Dimensions

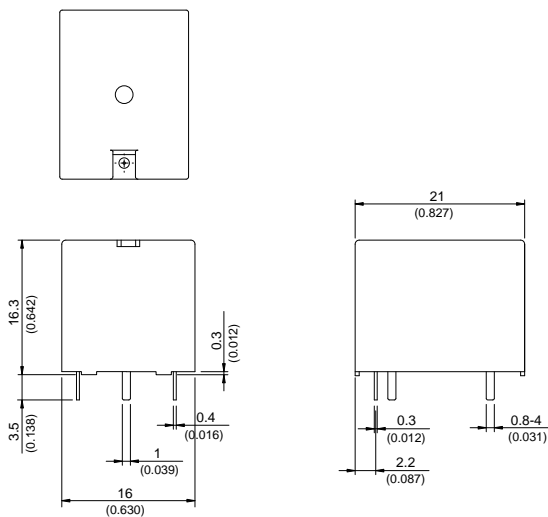

TOLERANCE:  
 LESS THAN: 1(0.039) ±0.1(0.004)  
 5(0.197) ±0.3(0.012)  
 20(0.787) ±0.5(0.020)  
 MORE THAN: 20(0.787) ±1(0.039)

## »» Wiring Diagram

BOTTOM VIEW

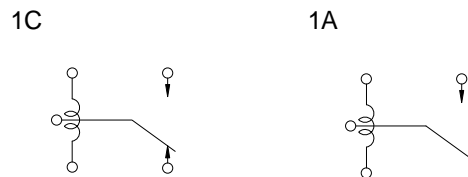

## »» PC Board Layout

BOTTOM VIEW

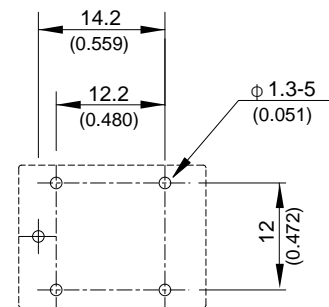

## »» Engineering Data

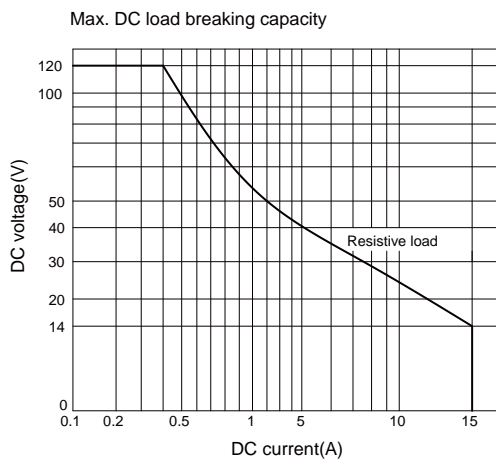
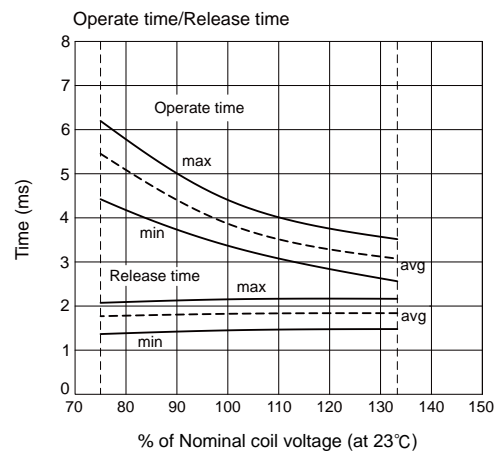
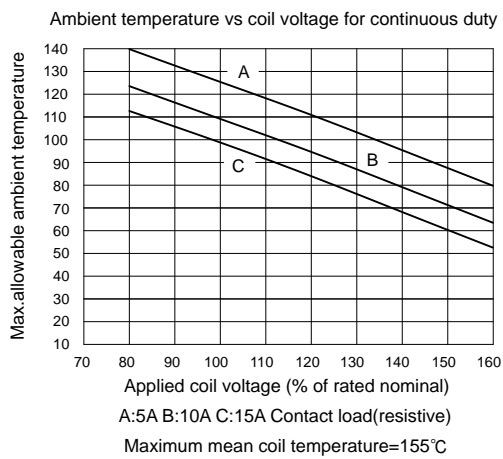
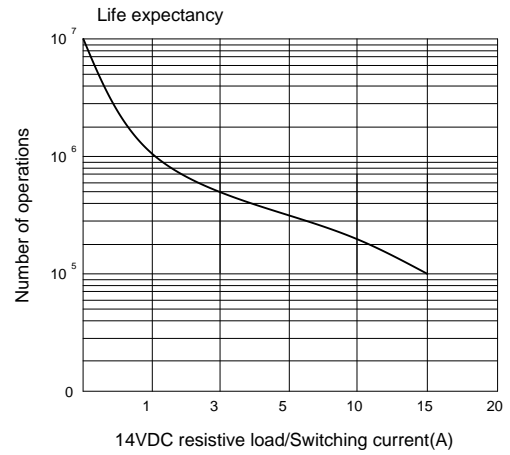
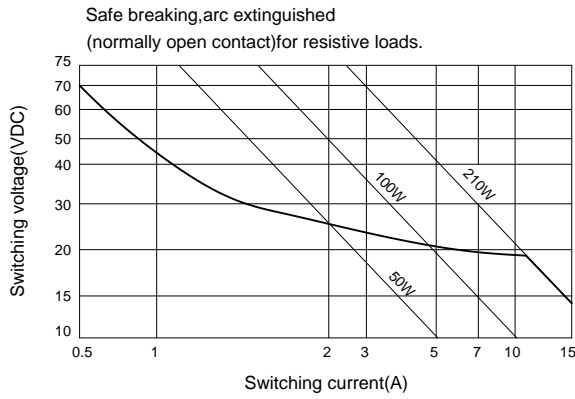

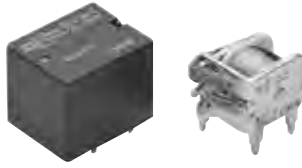
**»» Features**

- High power PCB relay with 40A rating.
- USA & European footprint are both available.
- Open frame, dust cover, flux-free type, and sealed type are available.
- Offering SPNC, SPNO, SPDT of contact configurations.
- Complies with RoHS-Directive 2011/65/EU and ELV-Directive 2000/53/EC.

**»» Type List**
**◆ Standard type**

Terminal style	Contact form	Designation (enclosure)			
		Open type	Flux tight	Sealed type	Sealed type washable
PCB terminal (Footprint for European)	1A (SPNO)	822E-1A	822E-1A-C	822E-1A-V	822E-1A-S
	1B (SPNC)	822E-1B	822E-1B-C	822E-1B-V	822E-1B-S
	1C (SPDT)	822E-1C	822E-1C-C	822E-1C-V	822E-1C-S
PCB terminal (Footprint for USA)	1A (SPNO)	822U-1A	822U-1A-C	822U-1A-V	822U-1A-S
	1B (SPNC)	822U-1B	822U-1B-C	822U-1B-V	822U-1B-S
	1C (SPDT)	822U-1C	822U-1C-C	822U-1C-V	822U-1C-S
PCB terminal (Footprint for USA different terminal)	1A (SPNO)	-----	822UA-1A-C	822UA-1A-V	822UA-1A-S
	1B (SPNC)		822UA-1B-C	822UA-1B-V	822UA-1B-S
	1C (SPDT)		822UA-1C-C	822UA-1C-V	822UA-1C-S

**◆ High sensitivity type**

PCB terminal (Footprint for European)	1A (SPNO)	822EN-1A	822EN-1A-C	822EN-1A-V	822EN-1A-S
	1B (SPNC)	822EN-1B	822EN-1B-C	822EN-1B-V	822EN-1B-S
	1C (SPDT)	822EN-1C	822EN-1C-C	822EN-1C-V	822EN-1C-S
PCB terminal (Footprint for USA)	1A (SPNO)	822UN-1A	822UN-1A-C	822UN-1A-V	822UN-1A-S
	1B (SPNC)	822UN-1B	822UN-1B-C	822UN-1B-V	822UN-1B-S
	1C (SPDT)	822UN-1C	822UN-1C-C	822UN-1C-V	822UN-1C-S
PCB terminal (Footprint for USA different terminal)	1A (SPNO)	-----	822UAN-1A-C	822UAN-1A-V	822UAN-1A-S
	1B (SPNC)		822UAN-1B-C	822UAN-1B-V	822UAN-1B-S
	1C (SPDT)		822UAN-1C-C	822UAN-1C-V	822UAN-1C-S

**»» Ordering Information**

822    E        -    1A    -          
 1       2       3                    4                    5                    6

- |   |  |
|---|--|
| 1. 822 -- Basic series designation<br><br>2. E -- Europe footprint<br>U -- USA footprint<br>UA -- USA different terminal<br><br>3. Blank -- Standard type<br>N -- High sensitivity type<br><br>4. 1A -- Single pole normally open<br>1B -- Single pole normally close | 1C -- Single pole double throw<br><br>5. Blank -- Open type<br>C -- Flux tight<br>V -- Sealed type<br>S -- Sealed type washable<br><br>6. <input type="checkbox"/> -- Coil voltage (please refer to the coil rating data for the availability) |
|---|--|

## »» Contact Rating

Resistive load	1A	1B	1C
	40A 14VDC	30A 14VDC	NC: 20A 14VDC ; NO: 40A 14VDC

## »» Coil Rating (DC)

## ◆Standard type

Rated voltage (V)	Rated current $\pm 10\%$ at 23°C (mA)	Coil resistance $\pm 10\%$ at 23°C ( $\Omega$ )	Max. continuous voltage at 85°C <sup>(1)</sup>	Pick up voltage(Max.) at 23°C	Drop out voltage(Min.) at 23°C	Power consumption at rated voltage
6	315	19	130 % of rated Voltage	3.3	0.6	approx. 1.6W
9	180	50		5.0	0.9	
12	133	90		6.8	1.2	
24	66	362		13.9	2.4	

Note : (1) Continuous contact current at 20A.

## ◆High sensitivity type

Rated voltage (V)	Rated current $\pm 10\%$ at 23°C (mA)	Coil resistance $\pm 10\%$ at 23°C ( $\Omega$ )	Max. continuous voltage at 85°C <sup>(1)</sup>	Pick up voltage(Max.) at 23°C	Drop out voltage(Min.) at 23°C	Power consumption at rated voltage
6	200	30	130 % of rated Voltage	75 % of rated Voltage	10 % of rated Voltage	approx. 1.2W
9	133	67.5				
12	100	120				
24	50	480				

Note : (1) Continuous contact current at 20A.

## »» Specification

Contact material	AgSnO alloy	
Contact voltage drop <sup>(1)</sup>	Typ. 40mV at 10A	
Insulation resistance <sup>(1)</sup>	50M $\Omega$ Min. (DC 500V)	
Operate time <sup>(1)</sup>	5ms Max.	
Release time <sup>(1)</sup>	4ms Max.	
Dielectric strength <sup>(1)</sup>	Between open contact	: AC 500V , 50/60Hz 1 min.
	Between contact and coil	: AC 500V , 50/60Hz 1 min.
Vibration resistance	Operating extremes	10~500Hz , 4.4G
	Damage limits	10~500Hz , 4.4G
Shock resistance	20G , 11ms , half sine wave pulse	
Life expectancy	Mechanical	10,000,000 operations (frequency 18,000 operations/hr)
	Electrical	100,000 operations (frequency 1,200 operations/hr)
Operating ambient temperature	-40~+85°C (no freezing)	
Weight	Approx. 17.5g	

Note : (1) Initial value. Operate and release time excluding contact bounce.

»» Outline Dimensions

◆ 822E,UA

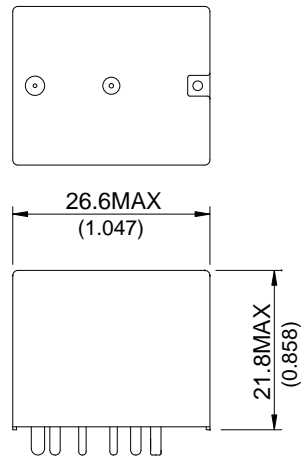
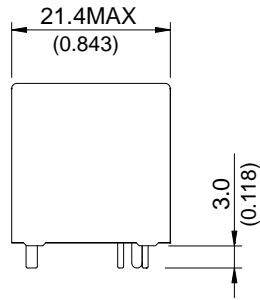

◆ 822E OPEN

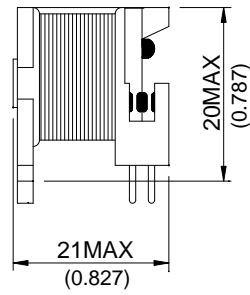
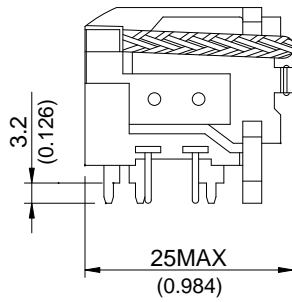

◆ 822U

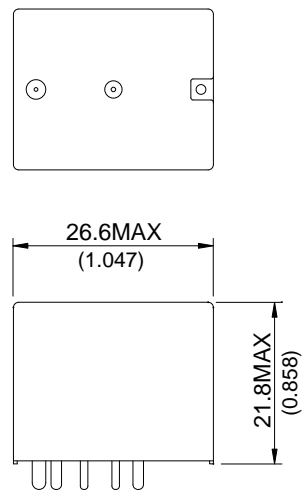
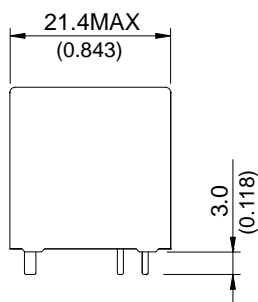

◆ 822U OPEN

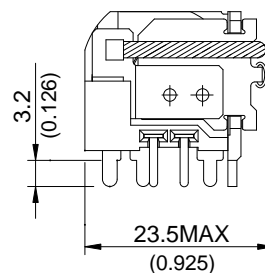
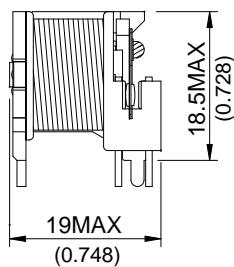

TOLERANCE:  
 LESS THAN: 1(0.039) ±0.1(0.004)  
 5(0.197) ±0.3(0.012)  
 20(0.787) ±0.5(0.020)  
 MORE THAN: 20(0.787) ±1(0.039)

# 822

## Wiring Diagram

BOTTOM VIEW

◆822E,822UA,822U(OPEN)

1C

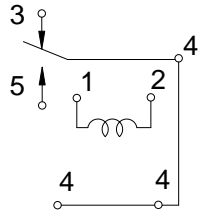

1B

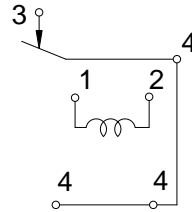

1A

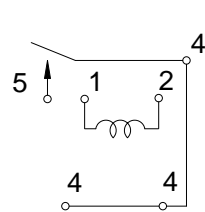

◆822U

1C

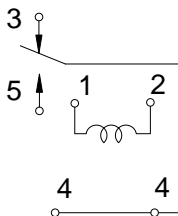

1B

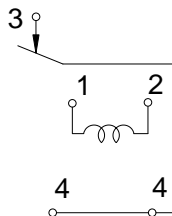

1A

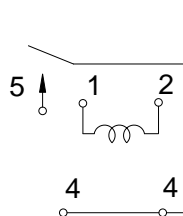

## PC Board Layout

BOTTOM VIEW

◆822E

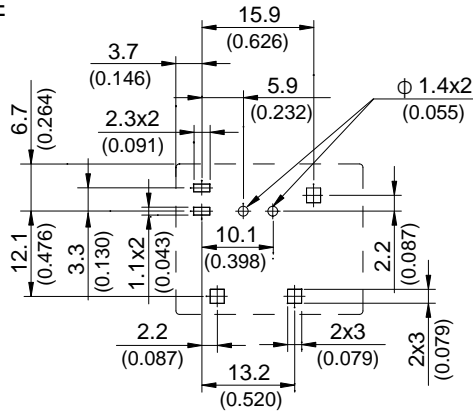

◆822E(OPEN)

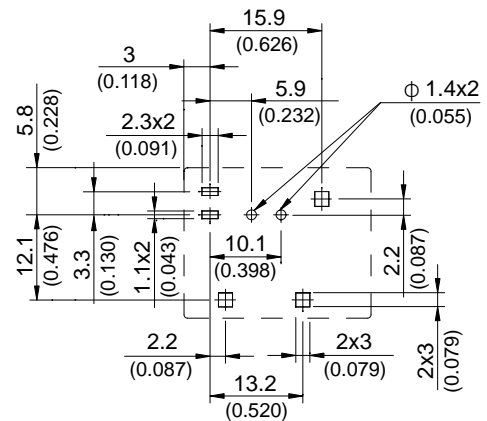

◆822U

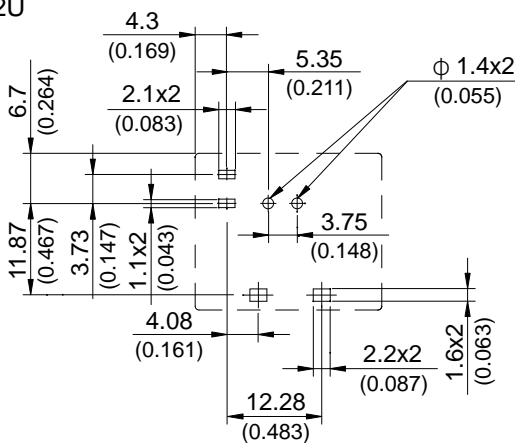

◆822U(OPEN)

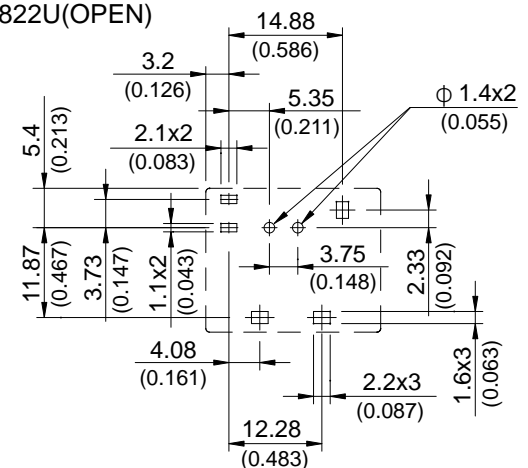

◆ 822UA

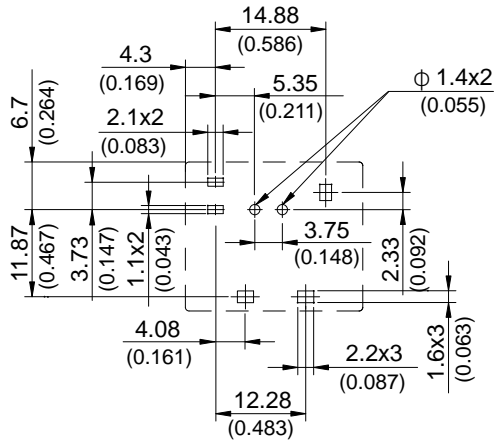

» Engineering Data

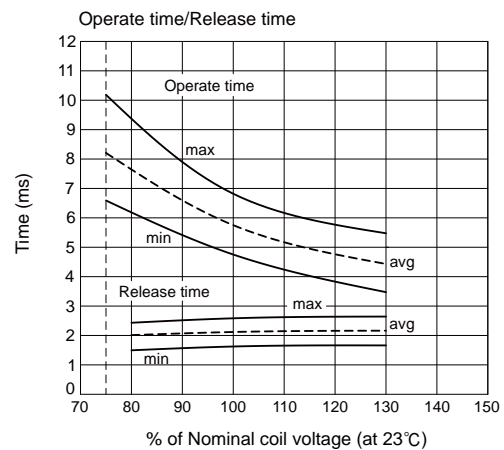
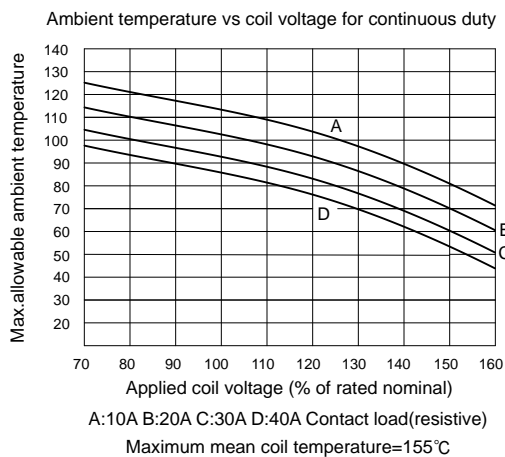
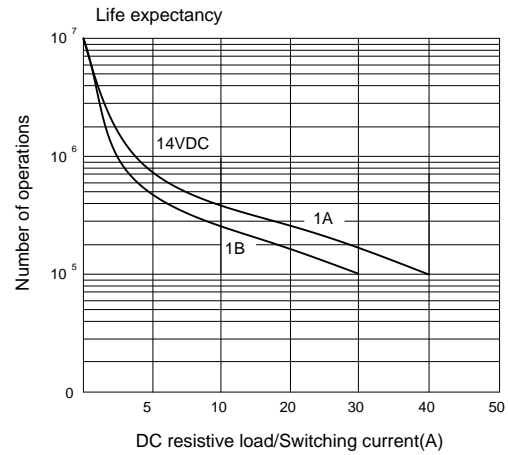
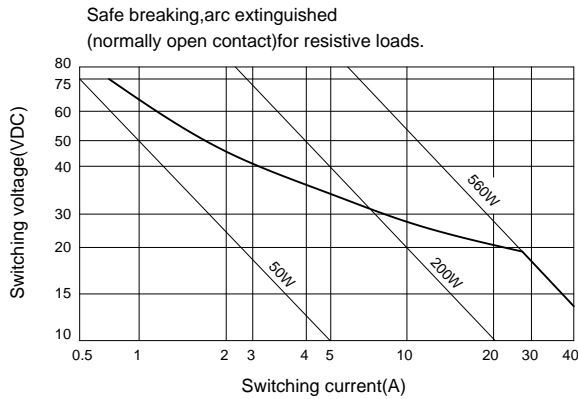



### »» Features

- Heavy duty 20/30A automotive PCB Relay.
- High dielectric strength up to 4000Vrms.
- SPNO, SPDT contact configurations.
- Dust cover, flux-free and sealed type.
- Complies with RoHS-Directive 2011/65/EU and ELV-Directive 2000/53/EC.

### »» Type List

Terminal style	Contact form	Designation		
		Flux tight	Sealed type	Sealed type washable
PCB terminal	1A (SPNO)	832AM-1A-C	832AM-1A-V	832AM-1A-S
	1C (SPDT)	832AM-1C-C	832AM-1C-V	832AM-1C-S

### »» Ordering Information

832 A M - 1A - C   
 1 2 3 4 5 6

- |  |   |
|--|---|
| 1. 832 -- Basic series designation                       | 1C -- Single pole double throw  |
| 2. A -- Different type (provided with 1 common terminal) | 5. C -- Flux tight  |
| 3. M -- Automotive relay                                 | V -- Sealed type  |
| 4. 1A -- Single pole normally open                       | S -- Sealed type washable   |
|  | 6. <input type="checkbox"/> -- Coil voltage (please refer to the coil rating data for the availability) |

### »» Contact Rating

Load type	1A	1C	
		NO	NC
Resistive load	30A 14VDC	20A 14VDC	10A 14VDC

### »» Coil Rating (DC)

Rated voltage (V)	Rated current $\pm 10\%$ at 23°C (mA)	Coil resistance $\pm 10\%$ at 23°C ( $\Omega$ )	Max. continuous voltage at 85°C <sup>(1)</sup>	Pick up Voltage (Max.) at 23°C	Drop out Voltage (Min.) at 23°C	Power consumption at rated voltage
9	93	97	120 % of rated voltage	75 % of rated voltage	10 % of rated voltage	approx. 0.93W
12	77	155				
24	36	660				

Note:(1)Continuous contact current at 10A.

# 832AM

## »» Specification

Contact material	AgSnO alloy	
Contact voltage drop <sup>(1)</sup>	Typ. 50mV at 10A	
Operate time <sup>(1)</sup>	15ms Max.	
Release time <sup>(1)</sup>	10ms Max.	
Insulation resistance <sup>(1)</sup>	100MΩ Min. (DC 500V)	
Dielectric strength <sup>(1)</sup>	Between open contact	: AC 500V , 50/60Hz 1min.
	Between contact and coil	: AC 500V , 50/60Hz 1min.
Vibration resistance	Operating extremes	10~500Hz , 4.4G
	Damage limits	10~500Hz , 4.4G
Shock resistance	Operating extremes	10G
	Damage limits	100G
Life expectancy	Mechanical	10,000,000 operations (frequency 18,000 operations/hr)
	Electrical	100,000 operations (frequency 1,200 operations/hr)
Operating ambient temperature	-55~+85°C (no freezing)	
Weight	Approx. 27g	

Note : (1) Initial value. Operate and release time excluding contact bounce.

## »» Outline Dimensions

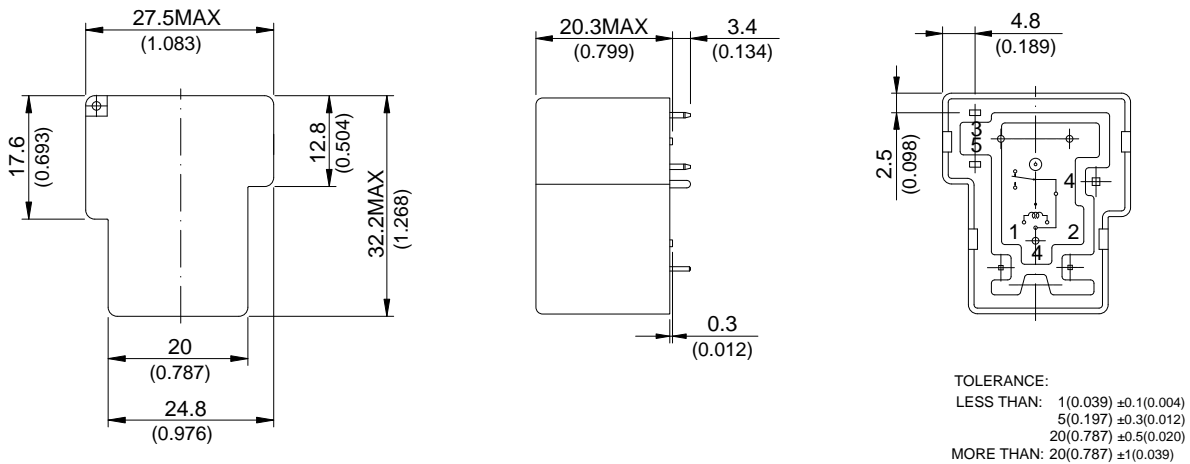

## »» Wiring Diagram

BOTTOM VIEW

1C

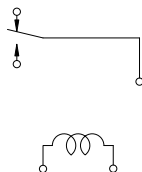

1A

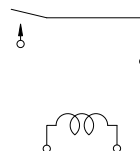

»» PC Board Layout  
BOTTOM VIEW

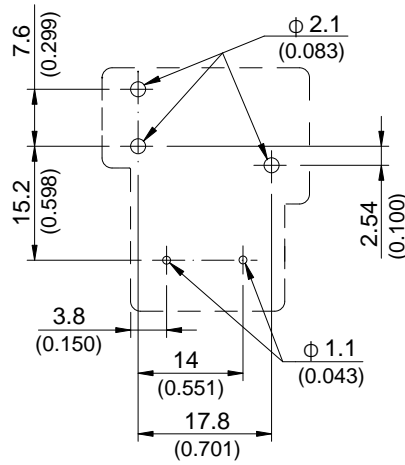

»» Engineering Data

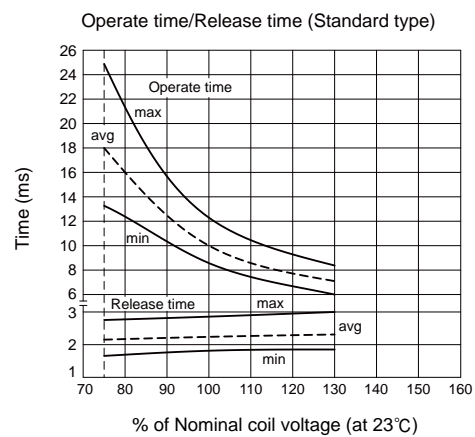
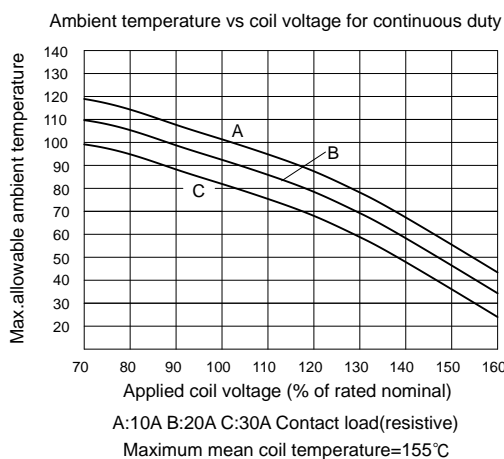
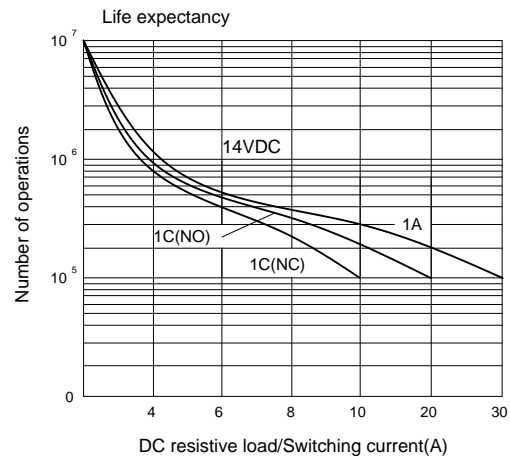
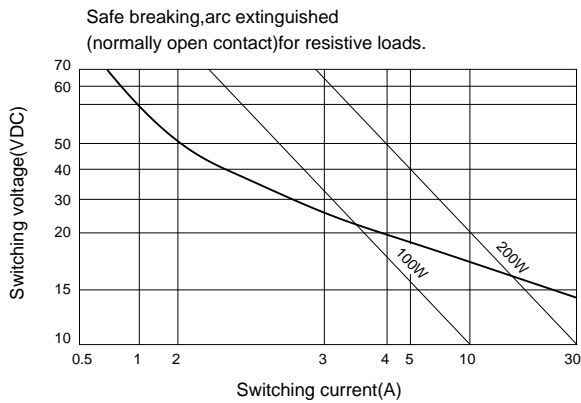

## 833HM

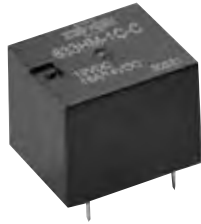

## »» Features

- Sugar cube automotive relay.
- General purpose applications for automotive & car alarm system.
- Optional for flux-free or sealed washable type.
- Complies with RoHS-Directive 2011/65/EU, and ELV-Directive 2000/53/EC.

## »» Type List

Terminal style	Contact form	Designation		
		Flux tight	Sealed type	Sealed type washable
PCB terminal	1C (SPDT)	833HM-1C-C	833HM-1C-V	833HM-1C-S
	1A (SPNO)	833HM-1A-C	833HM-1A-V	833HM-1A-S
	1B (SPNC)	833HM-1B-C	833HM-1B-V	833HM-1B-S

## »» Ordering Information

833    H    M    -    1C    -    C   

1       2       3       4       5       6

- |  |   |
|--|---|
| <p>1. 833 -- Basic series designation</p> <p>2. H -- High power type</p> <p>3. M -- Automotive relay</p> <p>4. 1A -- Single pole normally open<br/>1B -- Single pole normally close<br/>1C -- Single pole double throw</p> | <p>5. C -- Flux tight<br/>V -- Sealed type<br/>S -- Sealed type washable</p> <p>6. <input type="checkbox"/> -- Coil voltage (please refer to the coil rating data for the availability)</p> |
|--|---|

## »» Contact Rating

Resistive load	15A 14VDC
----------------	-----------

## »» Coil Rating (DC)

Rated voltage (V)	Rated current ±10 %at 23°C (mA)	Coil resistance ±10 %at 23°C (Ω)	Max. continuous voltage at 85°C <sup>(1)</sup>	Pick up voltage(Max.) at 23°C	Drop out voltage(Min.) at 23°C	Power consumption at rated voltage
9	50.0	180	120 % of rated voltage	75 % of rated voltage	10 % of rated voltage	approx. : 0.45W
12	37.5	320		rated voltage	rated voltage	
24	18.8	1,280		rated voltage	rated voltage	

Note : (1) Continuous contact current at 10A.

## »» Specification

Contact material	AgSnO alloy	
Contact voltage drop <sup>(1)</sup>	Typ. 100mV at 10A	
Operate time <sup>(1)</sup>	10ms Max.	
Release time <sup>(1)</sup>	5ms Max.	
Insulation resistance <sup>(1)</sup>	100MΩ Min. (DC 500V)	
Dielectric strength <sup>(1)</sup>	Between open contact	: AC 500V , 50/60Hz 1 minute.
	Between contact and coil	: AC 500V , 50/60Hz 1 minute.
Vibration resistance	Operating extremes	10~500Hz , 4.4G
	Damage limits	10~500Hz , 4.4G
Shock resistance	Operating extremes	10G
	Damage limits	100G
Life expectancy	Mechanical	10,000,000 operations (frequency 18,000 operations/hr)
	Electrical	30,000 operations (frequency 1,200 operations/hr)
Operating ambient temperature	-40~ +85°C (no freezing)	
Weight	approx. 10g	

Note : (1) Initial value. Operate and release time excluding contact bounce.

## »» Outline Dimensions

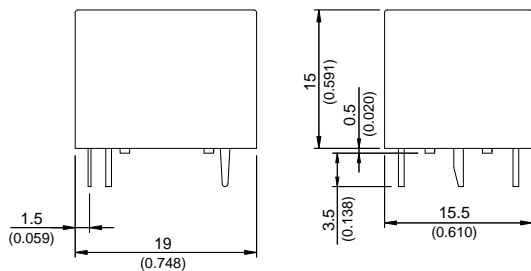

TOLERANCE:  
 LESS THAN: 1(0.039) ±0.1(0.004)  
 5(0.197) ±0.3(0.012)  
 20(0.787) ±0.5(0.020)  
 MORE THAN: 20(0.787) ±1(0.039)

## »» Wiring Diagram

BOTTOM VIEW

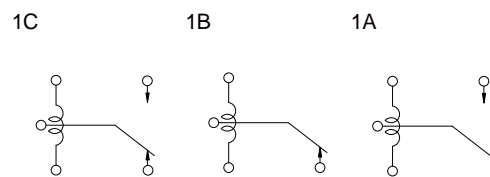

## »» PC Board Layout

BOTTOM VIEW

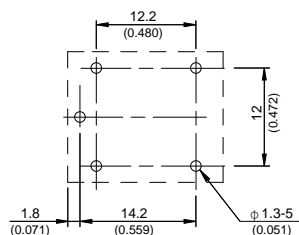

# 833HM

## »» Engineering Data

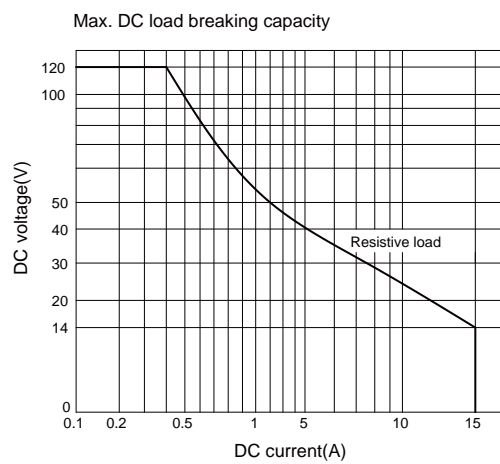
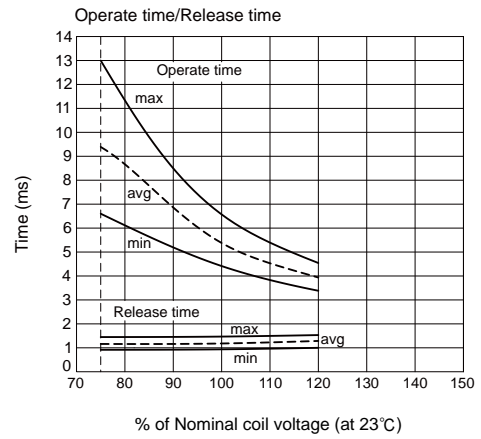
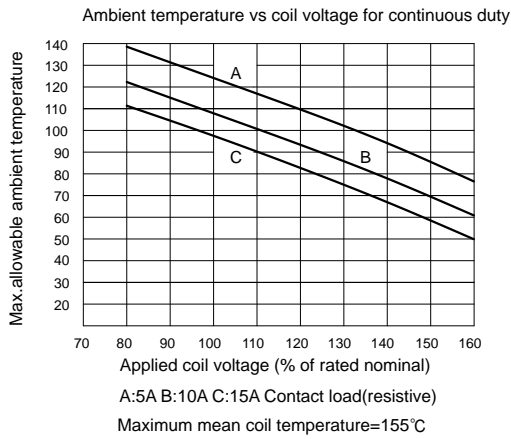
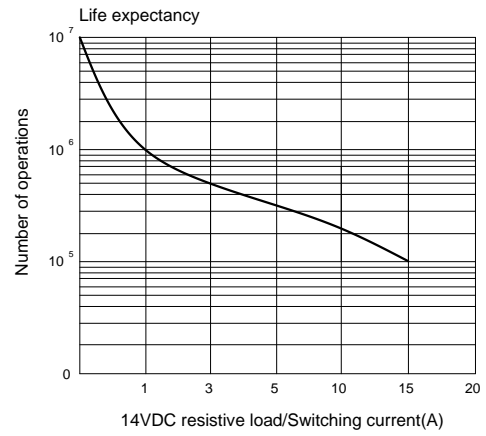



»» Features

- Miniature PCB relays 15A/14VDC
- Available for open frame type or flux free or sealed type.
- Single and twin relays are both available.
- Contact configurations of SPNC, SPNO, SPDT, SPDM-DB are available.
- General application for car alarm control, power window control, wiper control, door lock control, etc.
- Complies with RoHS-Directive 2011/65/EU, and ELV-Directive 2000/53/EC.

»» Type List

Terminal style	Contact form	Designation			
		Open type	Flux tight	Sealed type	Sealed type washable
PCB terminal	1A (SPNO)	861-1A	861-1A-C	861-1A-V	861-1A-S
	2A (SPDM)	861-2A	861-2A-C	861-2A-V	861-2A-S
	1C (SPDT)	861-1C	861-1C-C	861-1C-V	861-1C-S
	2C (SPDM-DB)	861-2C	861-2C-C	861-2C-V	861-2C-S
	1A (SPNO) x2	-----	861T-1A-C	861T-1A-V	861T-1A-S
	2A (SPDM) x2	-----	861T-2A-C	861T-2A-V	861T-2A-S
	1C (SPDT) x2	-----	861T-1C-C	861T-1C-V	861T-1C-S
	2C (SPDM-DB) x2	-----	861T-2C-C	861T-2C-V	861T-2C-S

»» Ordering Information

861  - 1A -    
 1 2 3 4 5

- |                                    |   |
|------------------------------------|---|
| 1. 861 -- Basic series designation | 2B -- Single pole double break  |
|                                    | 2C -- Single pole double make-double break  |
| 2. Blank -- Single relay           |   |
| T -- Twin relay                    | 4. Blank -- Open type   |
|                                    | C -- Flux tight   |
| 3. 1A -- Single pole normally open | V -- Sealed type  |
| 1B -- Single pole normally close   | S -- Sealed type washable   |
| 1C -- Single pole double throw     |   |
| 2A -- Single pole double make      | 5. <input type="checkbox"/> -- Coil voltage (please refer to the coil rating data for the availability) |

»» Contact Rating

Resistive load	SPNO	SPNC	SPDT
	15A/14VDC	10A/14VDC	NC:10A/14VDC , NO:15A/14VDC
	SPDM	SPDB	SPDM-DB
	10AX2/14VDC	7AX2/14VDC	DM:10AX2/14VDC , DB:7AX2/14VDC

## »» Coil Rating(DC)

Rated voltage (V)	Rated current $\pm 10\%$ at 23°C (mA)	Coil resistance $\pm 10\%$ at 23°C ( $\Omega$ )	Max. continuous voltage at 85°C <sup>(1)</sup>	Pick up voltage(Max.) at 23°C	Drop out voltage(Min.) at 23°C	Power consumption at rated voltage
6	187.5	32	125 % of rated voltage	60 % of rated voltage 67% (for 2C contact configuration only)	10 % of rated voltage	approx. 1.1W
9	123.2	73				
12	92.3	130				
24	46.1	520				

Note : (1) Continuous contact current at 10A.

## »» Specification

Contact material	AgSnO alloy	
Contact voltage drop <sup>(1)</sup>	Typ. 50mV at 10A	
Insulation resistance <sup>(1)</sup>	50M $\Omega$ Min. (DC 500V)	
Operate time <sup>(1)</sup>	4ms Max.	
Release time <sup>(1)</sup>	2ms Max.	
Dielectric strength <sup>(1)</sup>	Between open contact	: AC 500V , 50/60Hz 1 min.
	Between contact and coil	: AC 500V , 50/60Hz 1 min.
Vibration resistance	Operating extremes	10~500Hz , 4.4G
	Damage limits	10~500Hz , 4.4G
Shock resistance	10G , 11ms , half sine wave pulse	
Life expectancy	Mechanical	10,000,000 operations (frequency 18,000 operations/hr)
	Electrical	100,000 operations (frequency 1,800 operations/hr)
Operating ambient temperature	-40~+85°C (no freezing)	
Weight	Approx. 17.5g	

Note : (1) Initial value. Operate and release time excluding contact bounce.

## »» Outline Dimensions

◆861

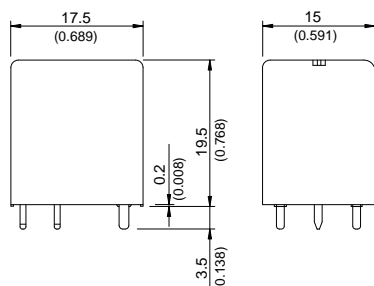

◆861 OPEN TYPE

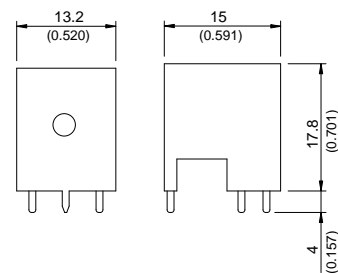

◆ 861T

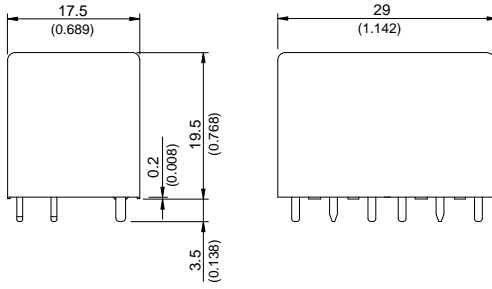

TOLERANCE:  
 LESS THAN: 1(0.039) ±0.1(0.004)  
 5(0.197) ±0.3(0.012)  
 20(0.787) ±0.5(0.020)  
 MORE THAN: 20(0.787) ±1(0.039)

»» Wiring Diagram  
 BOTTOM VIEW

◆ 861

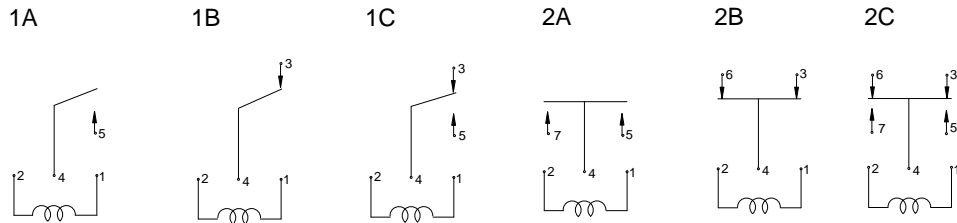

◆ 861T

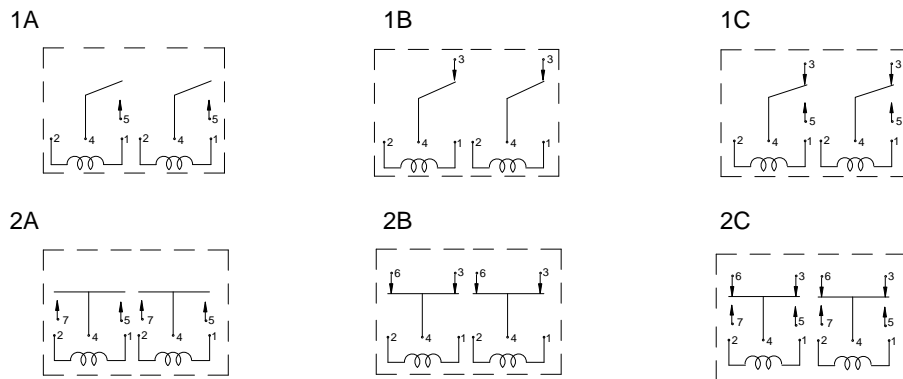

»» PC Board Layout  
 BOTTOM VIEW

◆ 861

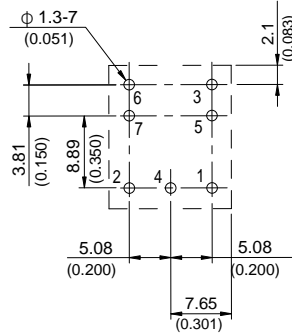

◆ 861 OPEN TYPE

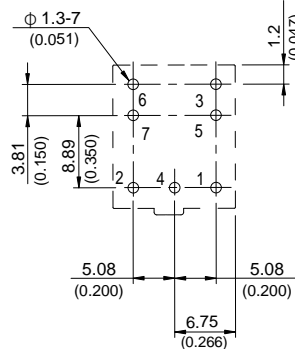

◆ 861T

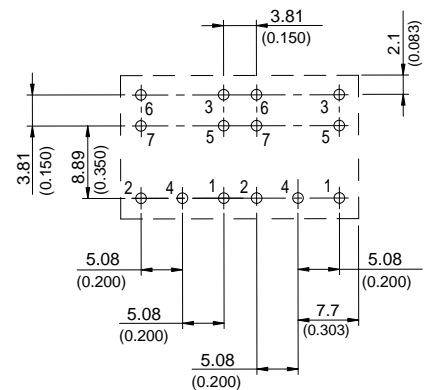

## »» Engineering Data

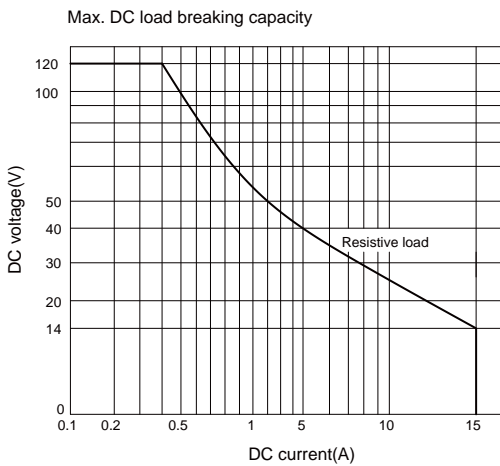
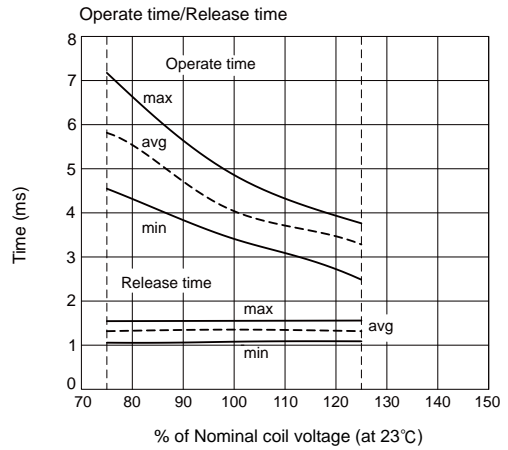
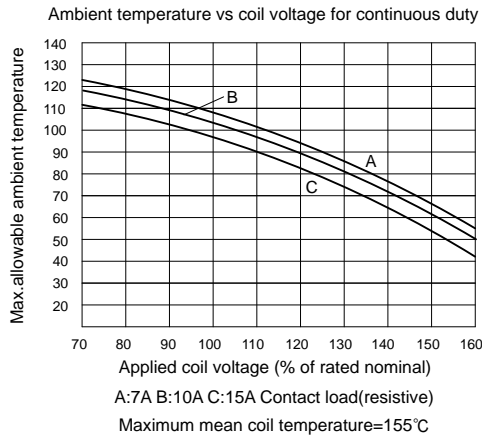
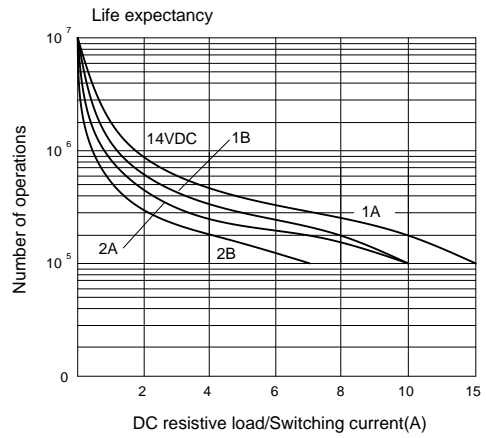
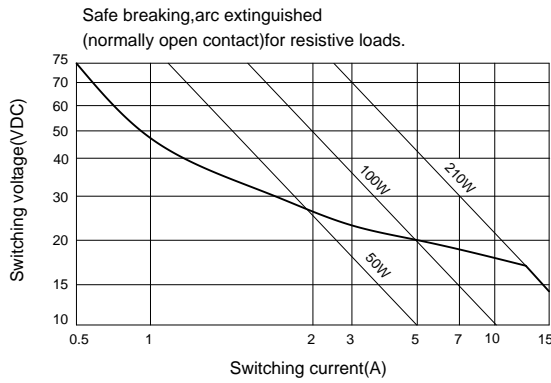



### »» Features

- Micro ISO automotive relay.
- SPNO & SPDT contact configurations.
- NO contacts switch 35A resistive load, NC contacts switch 20A resistive load, 100,000 ops., 23°C.
- Operating ambient temperature -40°C to 125°C.
- Available with plain cover and skirted cover.
- Optional resistor or diode for coil transient suppression.
- Complies with RoHS-Directive 2011/65/EU and ELV-Directive 2000/53/EC.

### »» Type List

Terminal style	Contact form	Designation (provided with)	Enclosure style			
			Dust cover	Dust cover /Fixed Base	Flux tight	Sealed type washable
Socket terminal	1A (SPNO)	-----	871-1A-D	871-1A-DF	871-1A-C	871-1A-S
		Resistor	871-1A-D-R1	871-1A-DF-R1	871-1A-C-R1	871-1A-S-R1
		Diode	871-1A-D-D1	871-1A-DF-D1	871-1A-C-D1	871-1A-S-D1
	1C (SPDT)	-----	871-1C-D	871-1C-DF	871-1C-C	871-1C-S
		Resistor	871-1C-D-R1	871-1C-DF-R1	871-1C-C-R1	871-1C-S-R1
		Diode	871-1C-D-D1	871-1C-DF-D1	871-1C-C-D1	871-1C-S-D1

### »» Ordering Information

871 - 1A - C -    
 1 2 3 4 5

- |  |  |
|--|--|
| <p>1. 871 -- Basic series designation</p> <p>2. 1A -- Single pole normally open<br/>1C -- Single pole double throw</p> <p>3. D -- Dust cover<br/>DF -- Dust cover / base holder type available<br/>C -- Flux tight<br/>S -- Sealed type washable</p> | <p>4. Blank -- Standard type<br/>R1 -- Coil parallel with 1/2W resistor for 6V 180Ω, 12V 680Ω, 24V 2700Ω<br/>D1 -- Coil parallel with diode 1N4007 the diode anode on # 85 terminal</p> <p>5. <input type="checkbox"/> -- Coil voltage (please refer to the coil rating data for the availability)</p> |
|--|--|

### »» Contact Rating

Resistive load	1A	1C
	35A 14VDC 15A 28VDC	NO: 35A 14VDC , 15A 28VDC NC: 20A 14VDC , 10A 28VDC

### »» Coil Rating (DC)

Rated voltage (V)	Rated current ±10 % at 23°C (mA)	Coil resistance ±10 % at 23°C (Ω)	Max. continuous voltage at 85°C	Pick up voltage(Max.) at 23°C	Drop out voltage(Min.) at 23°C	Power consumption at rated voltage
6	187.5	32	133 % of rated voltage	60 % of rated voltage	10 % of rated voltage	approx. 1.2W
12	97.5	123				
24	49.6	483				

## &gt;&gt;&gt; Specification

Contact material	AgSnO alloy	
Contact voltage drop <sup>(1)</sup>	Typ. 40mV at 10A	
Operate time <sup>(1)</sup>	10ms Max.	
Release time <sup>(1)</sup>	10ms Max.	
Insulation resistance <sup>(1)</sup>	20MΩ Min. (DC 500V)	
Dielectric strength <sup>(1)</sup>	Between open contact	: AC 500V , 50/60Hz 1 min.
	Between contact and coil	: AC 500V , 50/60Hz 1 min.
Vibration resistance	Operating extremes	10~500Hz , 5.0G
	Damage limits	10~500Hz , 5.0G
Shock resistance	Operating extremes	10G
	Damage limits	100G
Life expectancy	Mechanical	10,000,000 operations (frequency 18,000 operations/hr)
	Electrical	100,000 operations (frequency 1,800 operations/hr)
Operating ambient temperature	-40~+125°C (no freezing)	
Weight	Approx. 20 g	

Note : (1) Initial value. Operate and release time excluding contact bounce.

## &gt;&gt;&gt; Outline Dimensions

## ◆871 (C,D)

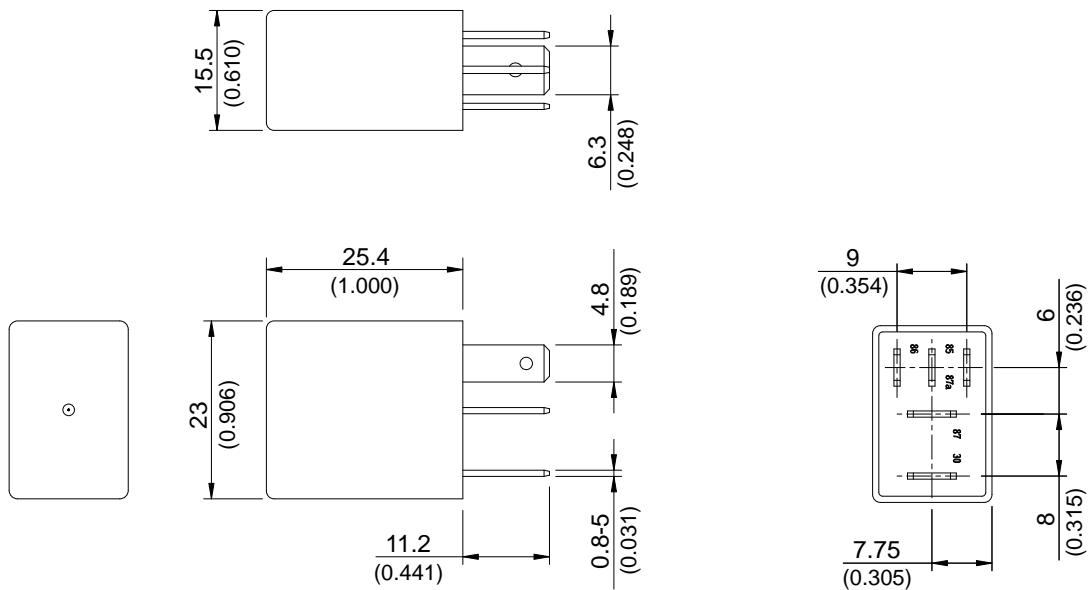

# 871

◆ 871 (DF)

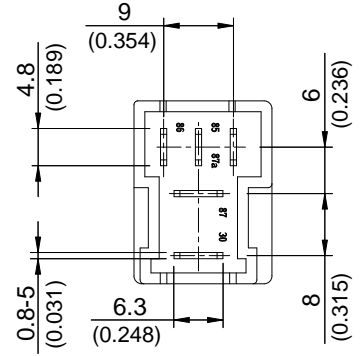
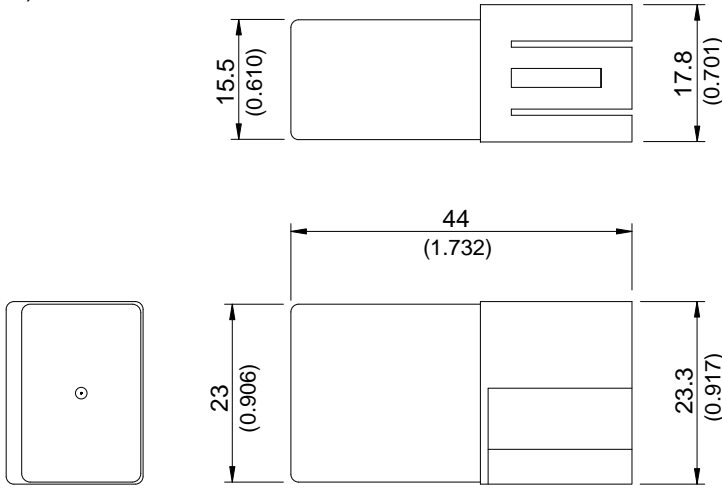

◆ 871 (S,V)

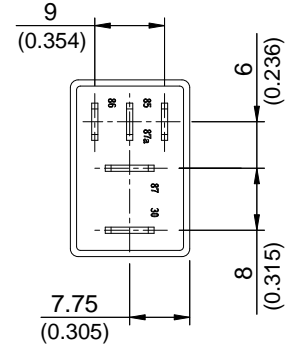
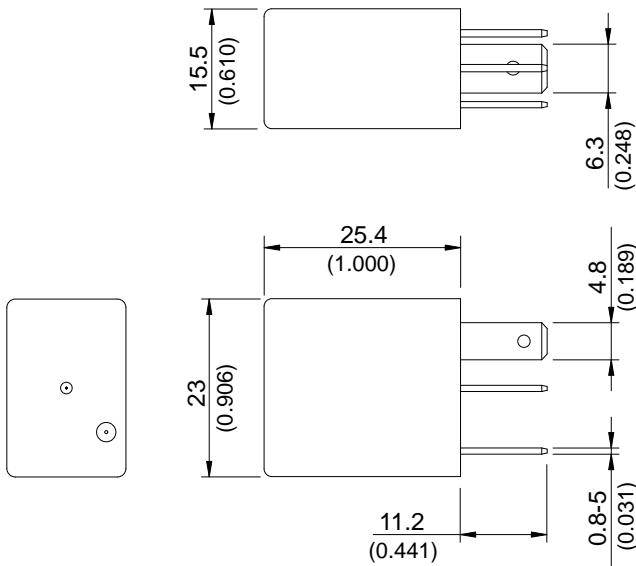

TOLERANCE:  
 LESS THAN: 1(0.039) ±0.1(0.004)  
 5(0.197) ±0.3(0.012)  
 20(0.787) ±0.5(0.020)  
 MORE THAN: 20(0.787) ±1(0.039)

»» Wiring Diagram  
 BOTTOM VIEW

1C

1A

1C

1A

1C

1A

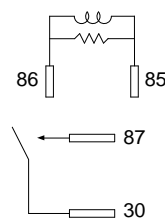
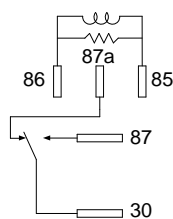
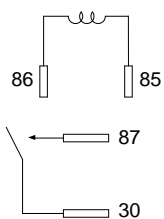
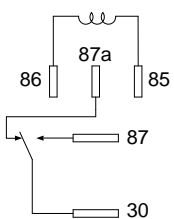

PROVIDED WITH  
 RESISTOR

PROVIDED WITH  
 RESISTOR

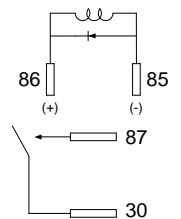
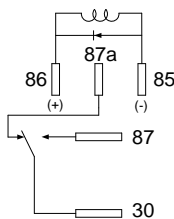

PROVIDED WITH  
 DIODE

PROVIDED WITH  
 DIODE

## »» Engineering Data

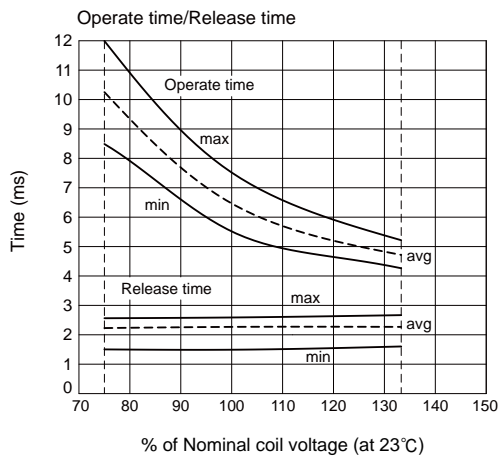
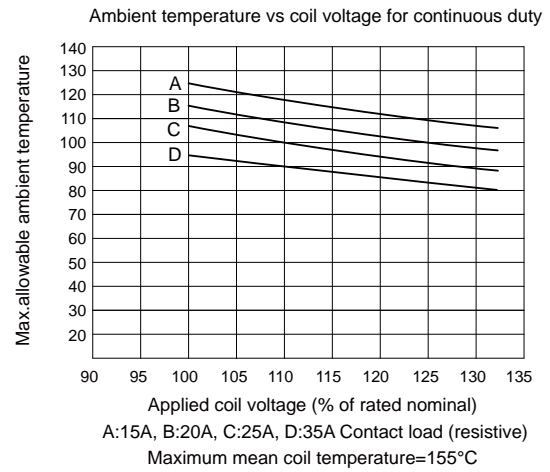
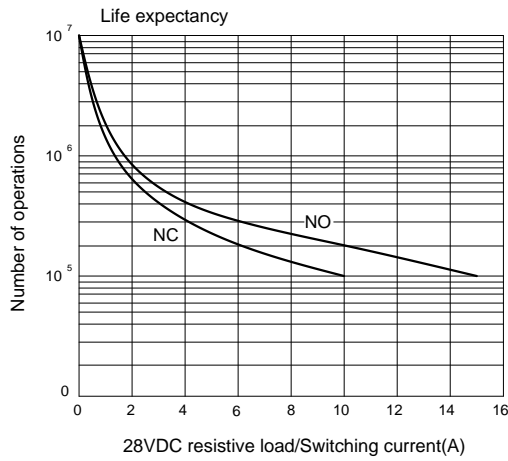
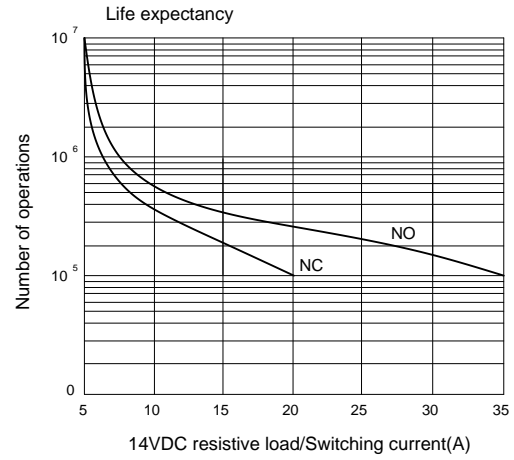
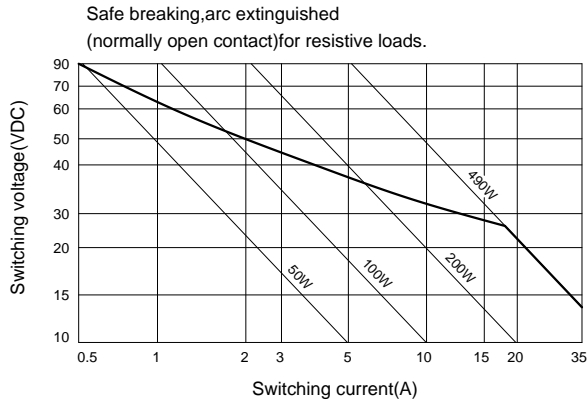

## 871A



## »» Features

- Micro ISO automotive relay.
- NO contacts switch 35A resistive load, 100,000 ops., 23°C.
- SPNO / 3 Terminals relay of cost saving version.
- Operating ambient temperature -40°C to 100°C.
- Complies with RoHS-Directive 2011/65/EU and ELV-Directive 2000/53/EC.

## »» Type List

Terminal style	Contact form	Designation (provided with)	Enclosure style		
			Dust cover	Flux tight	Sealed type washable
Socket terminal	1A (SPNO)	-----	871A-1A-D	871A-1A-C	871A-1A-S
		Resistor	871A-1A-D-R1	871A-1A-C-R1	871A-1A-S-R1
		Diode	871A-1A-D-D1	871A-1A-C-D1	871A-1A-S-D1

## »» Ordering Information

871    A    -    1A    -    C    -          
 1       2       3       4       5       6

- |   |   |
|---|---|
| <p>1. 871 -- Basic series designation</p> <p>2. A -- Three pin type</p> <p>3. 1A -- Single pole normally open</p> <p>4. D -- Dust cover<br/>C -- Flux tight<br/>S -- Sealed type washable</p> | <p>5. Blank -- Standard type<br/>R1 -- Coil parallel with 1/2W resistor for 12V 680Ω<br/>D1 -- Coil parallel with diode 1N4007 the diode anode on # 85,87 terminal</p> <p>6. <input type="checkbox"/> -- Coil voltage (please refer to the coil rating data for the availability)</p> |
|---|---|

## »» Contact Rating

Resistive load	35A 14VDC
----------------	-----------

## »» Coil Rating (DC)

Rated voltage (V)	Rated current ±10 % at 23°C (mA)	Coil resistance ±10 % at 23°C (Ω)	Max. continuous voltage at 85°C	Pick up voltage(Max.) at 23°C	Drop out voltage(Min.) at 23°C	Power consumption at rated voltage
12	97.5	123	16 V	8.0 V	1.2 V	approx. 1.2W

## »» Specification

Contact material	AgSnO alloy	
Contact voltage drop <sup>(1)</sup>	Typ. 40mV at 10A	
Operate time <sup>(1)</sup>	10ms Max.	
Release time <sup>(1)</sup>	10ms Max.	
Insulation resistance <sup>(1)</sup>	20MΩ Min. (DC 500V)	
Dielectric strength <sup>(1)</sup>	Between open contact	: AC 500V , 50/60Hz 1 min.
	Between contact and coil	: AC 500V , 50/60Hz 1 min.
Vibration resistance	Operating extremes	10~500Hz , 5.0G
	Damage limits	10~500Hz , 5.0G
Shock resistance	Operating extremes	10G
	Damage limits	100G
Life expectancy	Mechanical	1,000,000 operations (frequency 18,000 operations/hr)
	Electrical	100,000 operations (frequency 1,800 operations/hr)
Operating ambient temperature	-40~+100°C (no freezing)	
Weight	Approx. 20 g	

Note : (1) Initial value. Operate and release time excluding contact bounce.

## »» Outline Dimensions

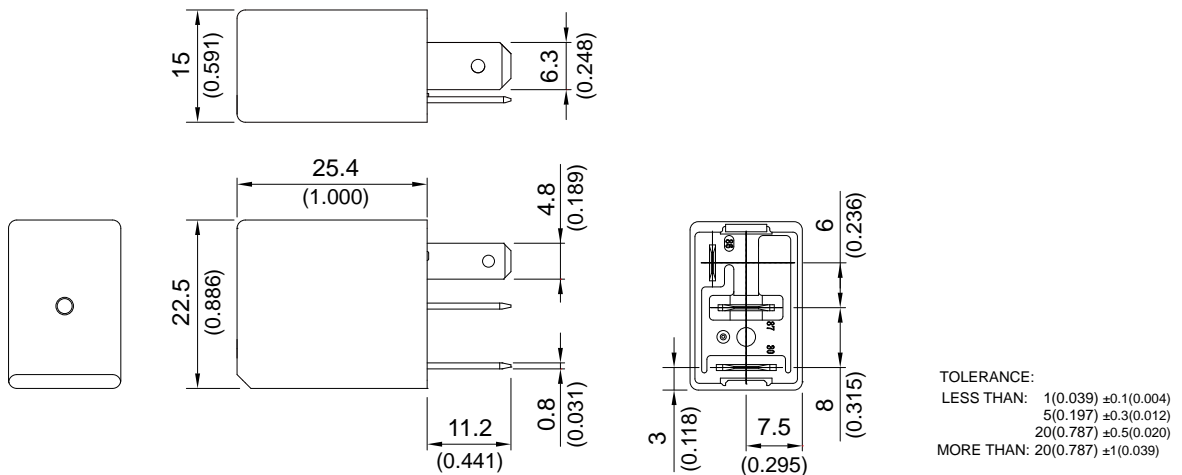

## »» Wiring Diagram

BOTTOM VIEW

1A

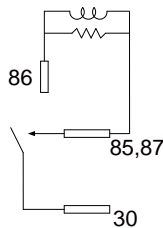
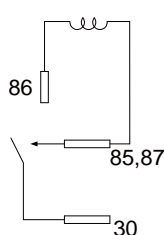

PROVIDED WITH  
RESISTOR

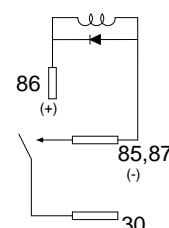

PROVIDED WITH  
DIODE



### »» Features

- Low profile PCB automotive relay.
- High rating 20A/14VDC ; motor load 5A/14VDC ; maximum carry current up to 35A.
- Optional SPNO, SPDT, DPNO contact configurations.
- General purpose application for motor control for power window, sunroof, door lock, and flasher control, etc.
- Complies with RoHS-Directive 2011/65/EU, and ELV-Directive 2000/53/EC.

### »» Type List

Terminal style	Contact form	Designation (provided with)		
		Flux tight	Sealed type	Sealed type washable
PCB terminal	1A (SPNO)	895-1A-C	895-1A-V	895-1A-S
		895-1A-C-H	895-1A-V-H	895-1A-S-H
	1C (SPDT)	895-1C-C	895-1C-V	895-1C-S
		895-1C-C-H	895-1C-V-H	895-1C-S-H
	2A (DPNO)	895-2A-C	895-2A-V	895-2A-S

### »» Ordering Information

895 - 1A - C -    
 1      2      3      4      5

- |   |   |
|---|---|
| 1. 895 -- Basic series designation                      | V -- Sealed type  |
|   | S -- Sealed type washable   |
| 2. 1A -- Single pole normally open                      |   |
| 1C -- Single pole double throw                          | 4. Blank -- Standard type   |
| 2A -- Single pole normally open with two N.O. terminals | H -- Enlarge contact spacing  |
| 3. C -- Flux tight                                      | 5. <input type="checkbox"/> -- Coil voltage (please refer to the coil rating data for the availability) |

### »» Contact Rating

#### ◆ 1P

Resistive load	NC : 10A 14VDC, NO : 20A 14VDC ; ON 1s / OFF 9s ; 100K ops.
Motor load	5A 14VDC, Inrush 25A ; ON 0.5s / OFF 9.5s ; 200K ops.
Max. carry current	35A/2min. , 25A/1hr (25°C nominal voltage) 30A/2min. , 20A/1hr (85°C nominal voltage)

#### ◆ 2A

Lamp load	2 NO 21WX6 Lamps 14VDC
Max. carry current	2X6A (25°C nominal voltage) 2X4A (85°C nominal voltage)

## »» Coil Rating (DC)

## ◆1P

Rated voltage (V)	Rated current ±10 % at 23°C (mA)	Coil resistance ±10 % at 23°C (Ω)	Max. continuous voltage at 85°C	Pick up voltage(Max.) at 23°C	Drop out voltage(Min.) at 23°C	Power consumption at rated voltage
5	128	39	120% of rated voltage	60% of rated voltage	8% of rated voltage	approx. 0.64W
9	71.1	127				
12	53.3	225				
24	26.7	900				

## ◆2A

Rated voltage (V)	Rated current ±10 % at 23°C (mA)	Coil resistance ±10 % at 23°C (Ω)	Max. continuous voltage at 85°C	Pick up voltage(Max.) at 23°C	Drop out voltage(Min.) at 23°C	Power consumption at rated voltage
9	111.1	81	110% of rated voltage	60% of rated voltage	8% of rated voltage	approx. 1.0W
12	83.3	144				

## ◆1P(-H)

Rated voltage (V)	Rated current ±10 % at 23°C (mA)	Coil resistance ±10 % at 23°C (Ω)	Max. continuous voltage at 85°C	Pick up voltage(Max.) at 23°C	Drop out voltage(Min.) at 23°C	Power consumption at rated voltage
12	67.4	178	120% of rated voltage	60% of rated voltage	8% of rated voltage	approx. 0.8W
24	33.3	720				

## »» Specification

Contact material	AgSnO alloy	
Contact voltage drop <sup>(1)</sup>	Typ. 80mV at 10A	
Operate time <sup>(1)</sup>	10ms Max.	
Release time <sup>(1)</sup>	5ms Max.	
Insulation resistance <sup>(1)</sup>	100MΩ Min. (DC 500V)	
Dielectric strength <sup>(1)</sup>	Between open contact	: AC 500V , 50/60Hz 1 min.
	Between contact and coil	: AC 500V , 50/60Hz 1 min.
Vibration resistance	Operating extremes	10~500Hz , 4.4G
	Damage limits	10~500Hz , 4.4G
Shock resistance	Operating extremes	10G
	Damage limits	100G
Life expectancy	Mechanical	10,000,000 operations (frequency 18,000 operations/hr)
	Electrical	100,000 operations (for 2A) (frequency 240 operations/hr)
Operating ambient temperature	-40~+85°C (no freezing)	
Weight	Approx. 6 g	

Note : (1) Initial value. Operate and release time excluding contact bounce.

## »» Outline Dimensions

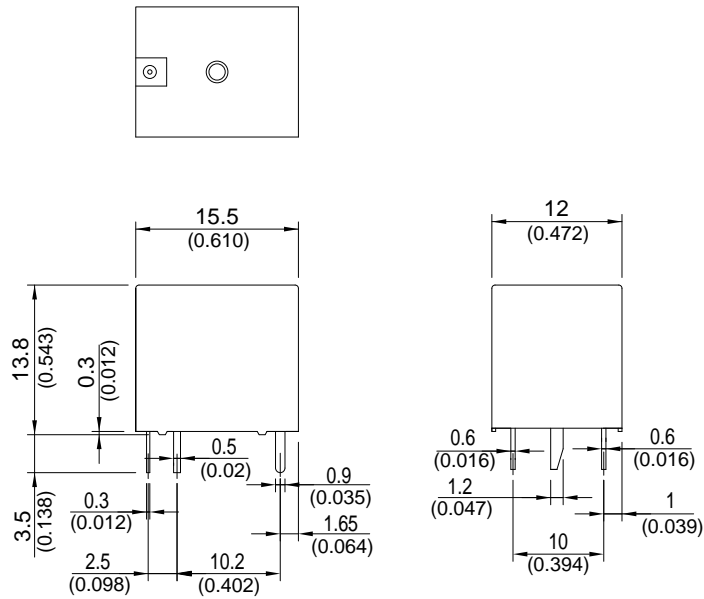

TOLERANCE:  
 LESS THAN: 1(0.039)  $\pm$ 0.1(0.004)  
 5(0.197)  $\pm$ 0.3(0.012)  
 20(0.787)  $\pm$ 0.5(0.020)  
 MORE THAN: 20(0.787)  $\pm$ 1(0.039)

## »» Wiring Diagram

BOTTOM VIEW

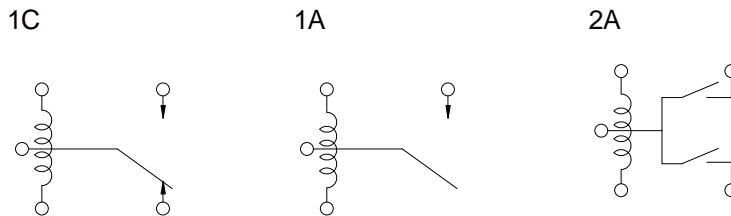

## »» PC Board Layout

BOTTOM VIEW

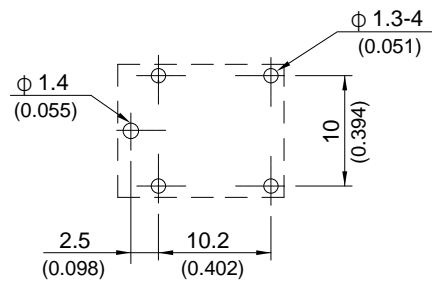

## »» Engineering Data

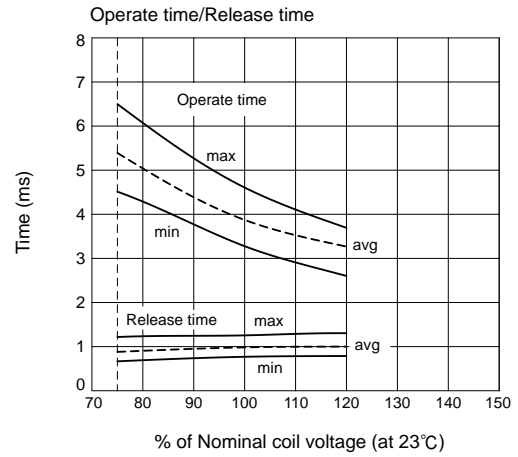
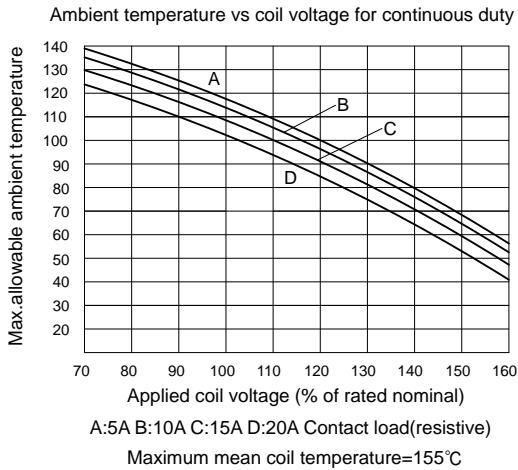
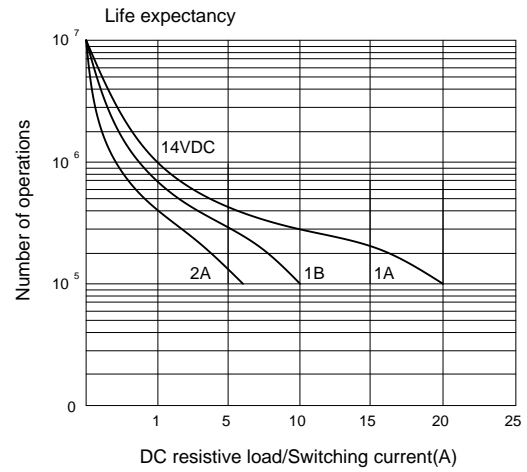
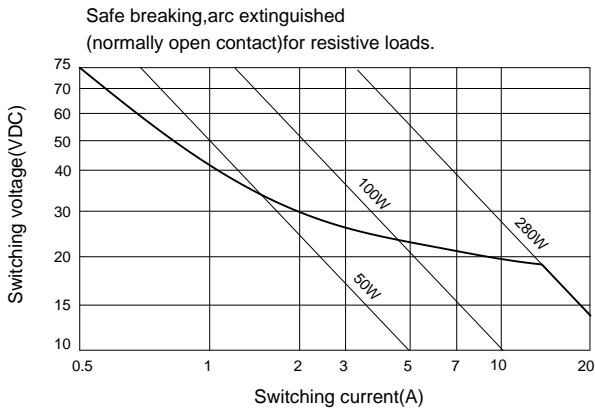

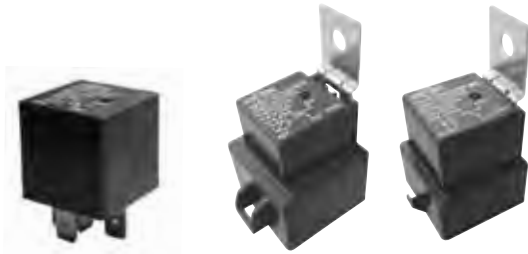

### »» Features

- Mini ISO automotive relay.
- SPNC, SPNO, SPDT, DPNO contact configurations.
- NO contacts switch 50A resistive load, NC contacts switch 30A resistive load, 100,000 ops., 23°C.
- Operating ambient temperature -40°C to 125°C.
- Available with plain cover, flanged cover, bracketed cover, skirted cover, and weather proof cover.
- Available with PCB terminals or quick connect terminals.
- Optional resistor or diode for coil transient suppression.
- Complies with RoHS-Directive 2011/65/EU and ELV-Directive 2000/53/EC.

### »» Type List

Terminal style	Contact form	Enclosure style		
		Dust cover	Flux tight	Sealed type washable
Socket terminal	1A (SPNO)	896-1AH-D	896-1AH-C	896-1AH-S
		896H-1AH-D	896H-1AH-C	896H-1AH-S
	1C (SPDT)	896-1CH-D	896-1CH-C	896-1CH-S
		896H-1CH-D	896H-1CH-C	896H-1CH-S
	2A (DPNO)	896-2AH-D	896-2AH-C	896-2AH-S
		896H-2AH-D	896H-2AH-C	896H-2AH-S
PCB terminal	1A (SPNO)	896P-1AH-D	896P-1AH-C	896P-1AH-S
		896HP-1AH-D	896HP-1AH-C	896HP-1AH-S
	1C (SPDT)	896P-1CH-D	896P-1CH-C	896P-1CH-S
		896HP-1CH-D	896HP-1CH-C	896HP-1CH-S
	2A (DPNO)	896P-2AH-D	896P-2AH-C	896P-2AH-S
		896HP-2AH-D	896HP-2AH-C	896HP-2AH-S

Terminal style	Contact form	Enclosure style	
		Flanged cover (dust cover)	Flanged cover (flux tight)
Socket terminal	1A (SPNO)	896-1AH-D1	896-1AH-C1
		896H-1AH-D1	896H-1AH-C1
	1C (SPDT)	896-1CH-D1	896-1CH-C1
		896H-1CH-D1	896H-1CH-C1
	2A (DPNO)	896-2AH-D1	896-2AH-C1
		896H-2AH-D1	896H-2AH-C1



Terminal style	Contact form	Enclosure style	
		Steel bracket ( dust cover)	Steel bracket (flux tight)
Socket terminal	1A (SPNO)	896-1AH-D1S	896-1AH-C1S
		896H-1AH-D1S	896H-1AH-C1S
	1C (SPDT)	896-1CH-D1S	896-1CH-C1S
		896H-1CH-D1S	896H-1CH-C1S
	2A (DPNO)	896-2AH-D1S	896-2AH-C1S
		896H-2AH-D1S	896H-2AH-C1S

Terminal style	Contact form	Designation (provided with)	Enclosure style	
			Steel bracket ( dust cover with shroud)	Steel bracket ( dust cover with weather proof)
Socket terminal	1C (SPDT)	Resistor	896H-1CH-D1SF-R1	896H-1CH-D1SW-R1

»» Ordering Information

896            -    1AH    -    C    -        -               

1        2        3        4        5        6        7        8        9

- |  |  |
|--|--|
| <p>1. 896 -- Basic series designation</p> <p>2. Blank -- Standard type<br/>H -- High power type</p> <p>3. Blank -- Socket terminal<br/>P -- PCB terminal</p> <p>4. 1AH -- Single pole normally open, contact material AgSnO<br/>1BH -- Single pole normally closed, contact material AgSnO<br/>1CH -- Single pole double throw, contact material AgSnO<br/>2AH -- Double pole double make, contact material AgSnO<br/>2AUH -- Single pole normally open, contact material AgSnO (2 × # 87 terminal)</p> <p>5. D -- Dust cover<br/>C -- Flux tight<br/>S -- Sealed type washable<br/>C1 -- Flanged cover (flux tight)<br/>D1 -- Flanged cover (dust cover)<br/>S1 -- Flanged cover (sealed type washable)</p> | <p>D1S -- Steel bracket (dust cover)<br/>C1S -- Steel bracket (flux tight)<br/>S1S -- Steel bracket (sealed type washable)<br/>D1SF -- Steel bracket (dust cover with shroud)<br/>D1SW -- Steel bracket (dust cover with weather proof)<br/>DUSW -- Dust cover with weather proof</p> <p>6. Blank -- Standard type<br/>R1 -- Coil parallel with resistor 1/2W for 12V 680Ω , 24V 2700Ω</p> <p>7. Blank -- Standard type<br/>T -- Special requirement for Tin plated terminal</p> <p>8. Blank -- Standard type<br/>001 -- Coil parallel with diode 1N4007 the diode anode on # 85 terminal<br/>002 -- Coil parallel with diode 1N4007 the diode cathode on # 85 terminal</p> <p>9. <input type="checkbox"/> -- Coil voltage (please refer to the coil rating data for the availability)</p> |
|--|--|

## »» Contact Rating

Type	896 1A	896 1B	896 1C	896 2A
Resistive load	40A 14VDC	40A 14VDC	NO : 40A 14VDC NC : 30A 14VDC	2×15A 14VDC

Type	896H 1A	896H 1B	896H 1C	896H 2A
Resistive load	50A 14VDC 20A 28VDC	40A 14VDC 15A 28VDC	NO : 50A 14VDC, 20A 28VDC NC : 30A 14VDC, 15A 28VDC	2×30A 14VDC 2×10A 28VDC

## »» Coil Rating(DC)

Rated voltage (V)	Rated current ±10 % at 23°C (mA)	Coil resistance ±10 % at 23°C (Ω)	Max. continuous Voltage at 85°C <sup>(1)</sup>	Pick up voltage(Max.) at 23°C	Drop out voltage(Min.) at 23°C	Power consumption at rated voltage
12	133	90	120 % of rated voltage	65 % of rated voltage	10 % of rated voltage	approx. 1.6W
24	66.7	360				

Notes : (1) Without switching the load.

## »» Specification

Contact material	AgSnO alloy	
Contact voltage drop <sup>(1)</sup>	Typ. 50mV at 10A	
Insulation resistance <sup>(1)</sup>	20MΩ Min. (DC 500V)	
Operate time <sup>(1)</sup>	20ms Max.	
Release time <sup>(1)</sup>	20ms Max.	
Dielectric strength <sup>(1)</sup>	Between open contact	: AC 500V , 50/60Hz 1 min.
	Between contact and coil	: AC 500V , 50/60Hz 1 min.
Vibration resistance	Operating extremes	10~500Hz , 5.0G
	Damage limits	10~500Hz , 5.0G
Shock resistance	Operating extremes	10G
	Damage limits	100G
Life expectancy	Mechanical	10,000,000 operations (frequency 18,000 operations/hr)
	Electrical	100,000 operations (frequency 1,200 operations/hr)
Operating ambient temperature	-40~+125°C (no freezing)	
Weight	Approx. 40 g	

Note : (1) Initial value. Operate and release time excluding contact bounce.

## &gt;&gt;&gt; Outline Dimensions

## ◆ 896,896H (C,D,S)

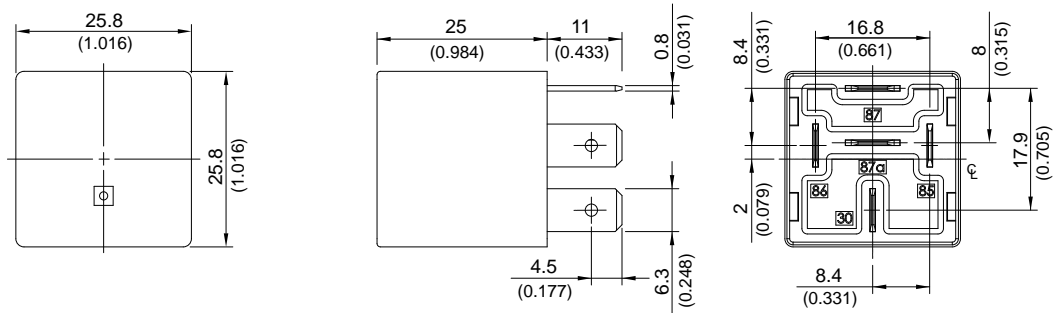

## ◆ 896,896H (C1,D1,S1)

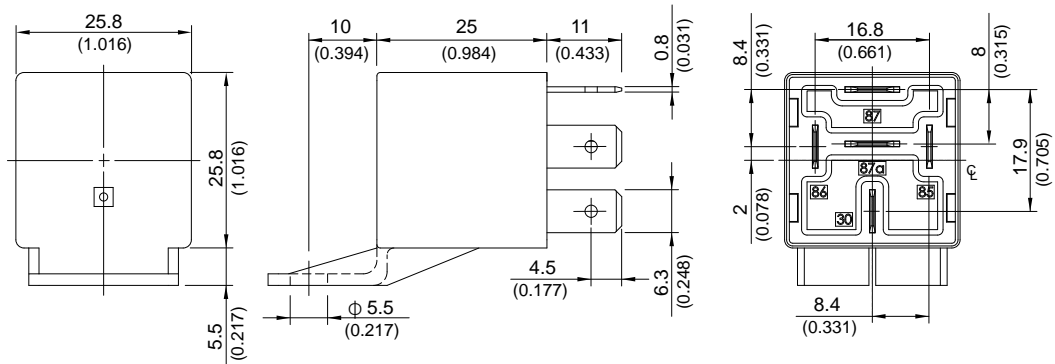

## ◆ 896,896H (C1S,D1S,S1S)

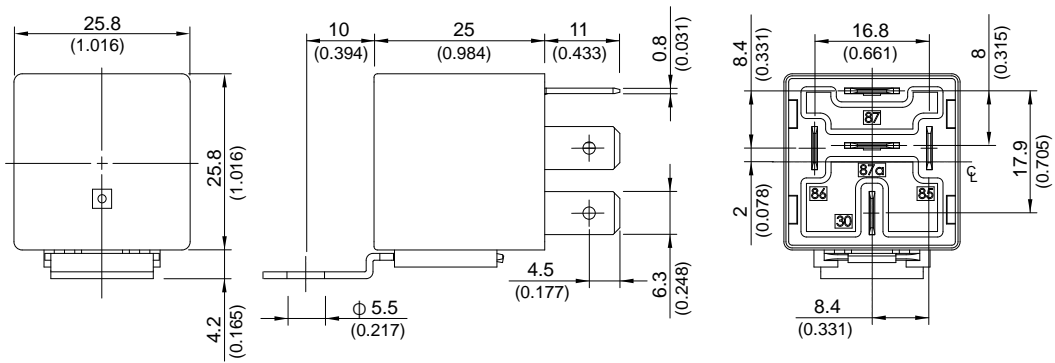

## ◆ 896P,896HP (C,D,S)

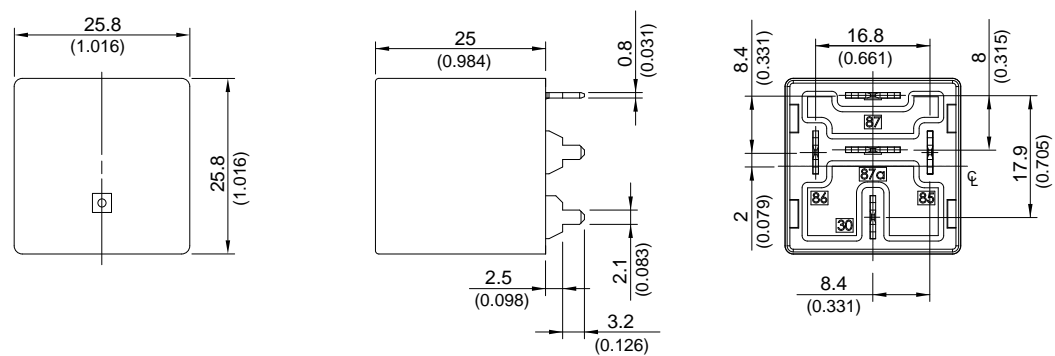

◆896H (D1SF)

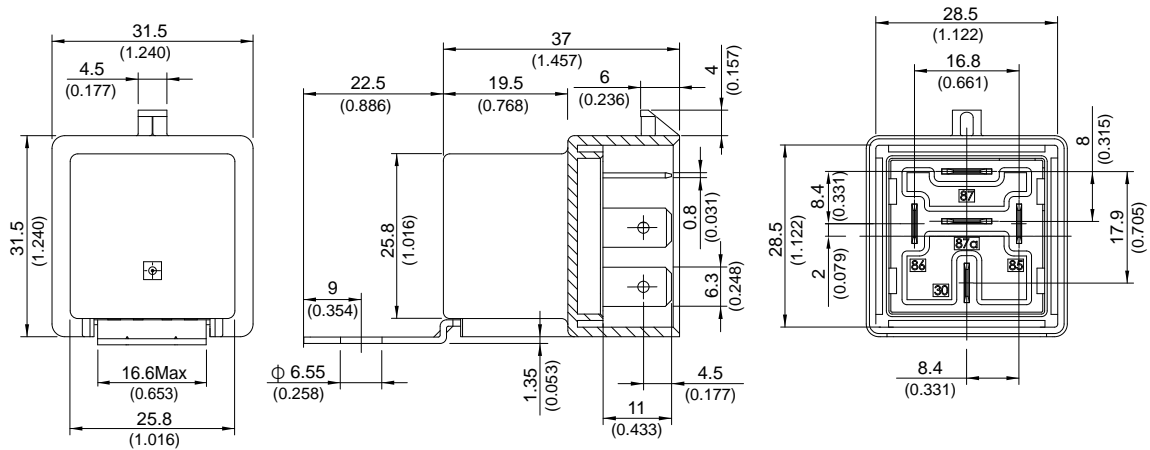

◆896H (D1SW)

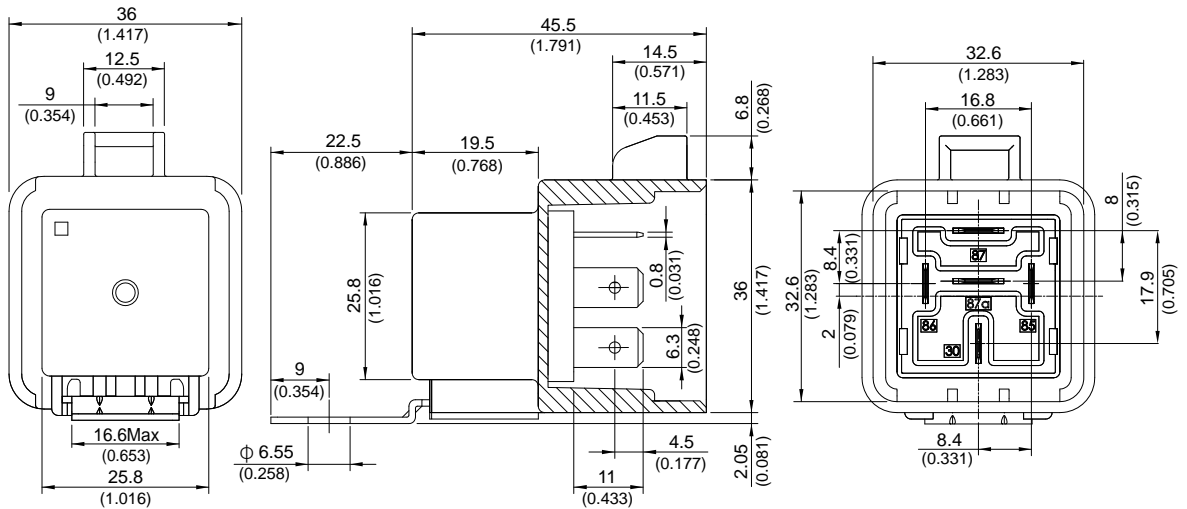

◆896H (DUSW)

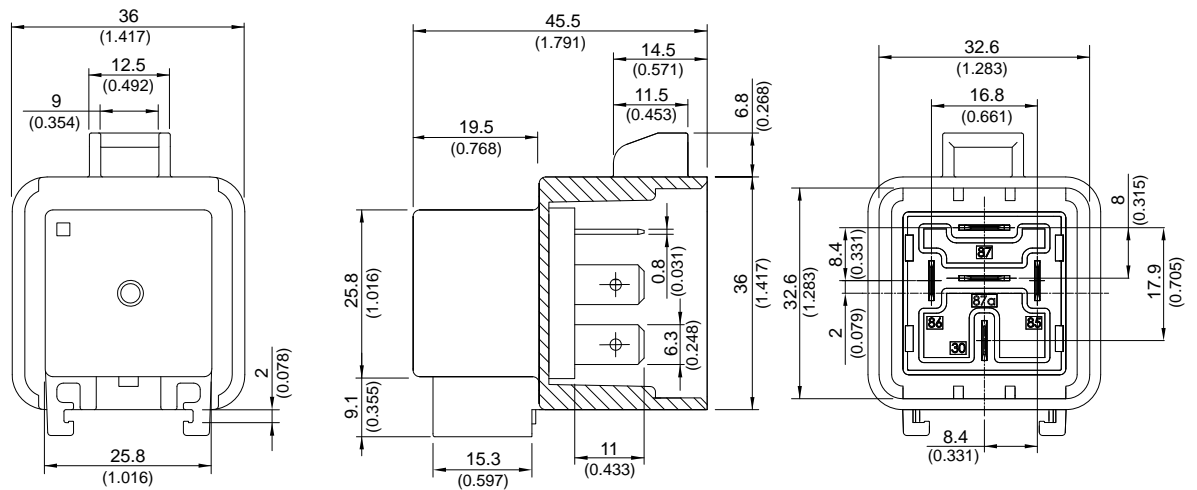

TOLERANCE:  
 LESS THAN: 1(0.039) ±0.1(0.004)  
 5(0.197) ±0.3(0.012)  
 20(0.787) ±0.5(0.020)  
 MORE THAN: 20(0.787) ±1(0.039)

## Wiring Diagram BOTTOM VIEW

1A

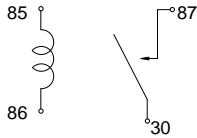

1B

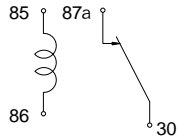

1C

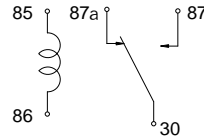

2AU

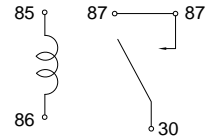

2A

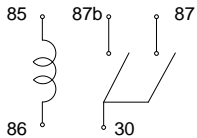

R1

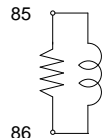

001

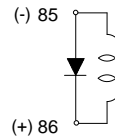

002

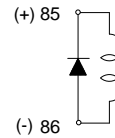

## PC Board Layout BOTTOM VIEW

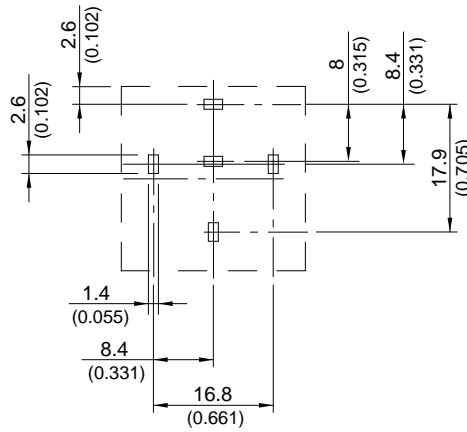

## Engineering Data

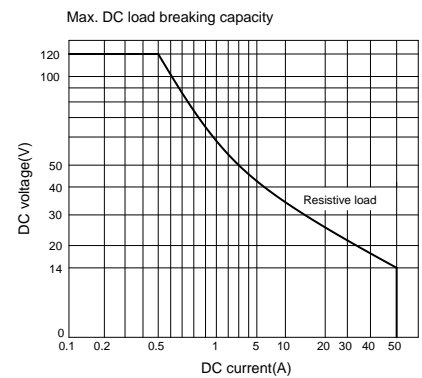
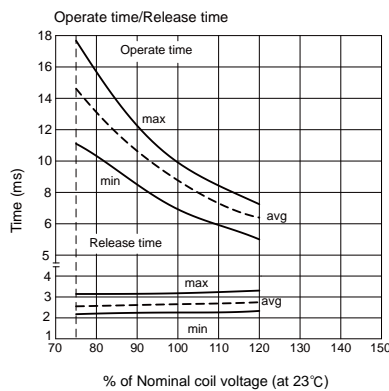
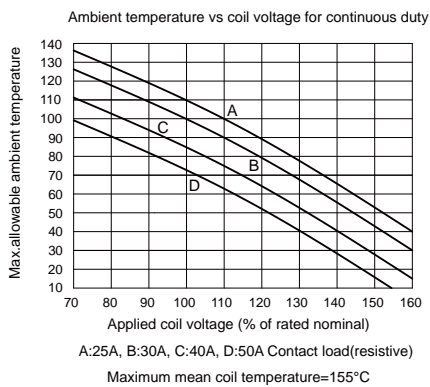
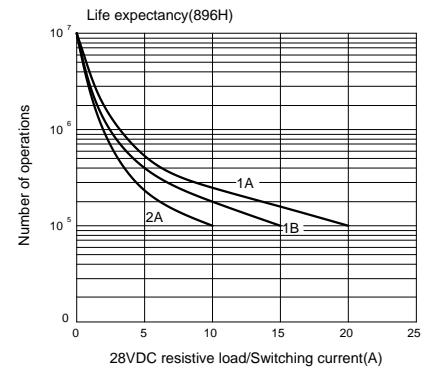
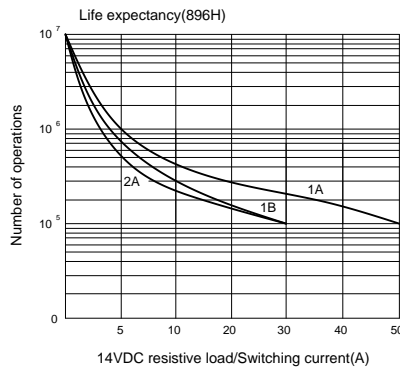
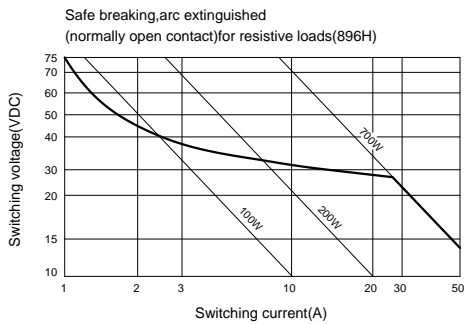

**»» Features**

- High Power Mini ISO automotive relay.
- Switches up to 70A resistive load, 100,000 ops., 23°C.
- Operating ambient temperature -40°C to 125°C.
- Available with plain cover, flanged cover, bracketed cover, skirted cover, and weather proof cover.
- Available with PCB terminals or quick connect terminals.
- Optional resistor or diode for coil transient suppression.
- Complies with RoHS-Directive 2011/65/EU and ELV-Directive 2000/53/EC.

**»» Type List**

Terminal style	Contact form	Designation (provided with)	Enclosure style		
			Dust cover	Flux tight	Sealed type washable
Socket terminal	1A (SPNO)	-----	897-1AH-D	897-1AH-C	897-1AH-S
		Resistor	897-1AH-D-R1	897-1AH-C-R1	897-1AH-S-R1
PCB terminal <sup>(1)</sup>	1A (SPNO)	-----	897P-1AH-D	897P-1AH-C	897P-1AH-S
		Resistor	897P-1AH-D-R1	897P-1AH-C-R1	897P-1AH-S-R1
Terminal style	Contact form	Designation (provided with)	Enclosure style		
			Flanged cover (dust cover)	Flanged cover (flux tight)	
Socket terminal	1A (SPNO)	-----	897-1AH-D1	897-1AH-C1	
		Resistor	897-1AH-D1-R1	897-1AH-C1-R1	
Terminal style	Contact form	Designation (provided with)	Enclosure style		
			Steel bracket (dust cover)	Steel bracket (flux tight)	
Socket terminal	1A (SPNO)	-----	897-1AH-D1S	897-1AH-C1S	
		Resistor	897-1AH-D1S-R1	897-1AH-C1S-R1	
Terminal style	Contact form	Designation (provided with)	Enclosure style		
			Steel bracket (dust cover with shroud)	Steel bracket (dust cover with weather proof)	
Socket terminal	1A (SPNO)	Resistor	897-1AH-D1SF-R1	897-1AH-D1SW-R1	

Note : (1) Special PCB terminal version (NO, COM 3 pin type) are available.

**»» Ordering Information**

897        -    1AH    -    C    -        -           

1        2        3        4        5        6        7        8

- |          |  |      |   |
|----------|--|------|---|
| 1. 897   | -- Basic series designation                          | 4. D | -- Dust cover                           |
| 2. Blank | -- Socket terminal                                   | C    | -- Flux tight                           |
| P        | -- PCB terminal                                      | S    | -- Sealed type washable                 |
| P1       | -- Special PCB terminal (NO,COM 3 pin type)          | D1   | -- Flanged cover (dust cover)           |
| 3. 1AH   | -- Single pole normally open, contact material AgSnO | C1   | -- Flanged cover (flux tight)           |
|          |  | S1   | -- Flanged cover (sealed type washable) |
|          |  | D1S  | -- Steel bracket (dust cover)           |

- C1S -- Steel bracket (flux tight)  
 S1S -- Steel bracket (sealed type washable)  
 D1SF -- Steel bracket (dust cover with shroud)  
 D1SW -- Steel bracket (dust cover with weather proof)  
 DUSW -- Dust cover with weather proof
5. Blank -- Standard type  
 R1 -- Coil parallel with resistor 1/2W for 12V 680Ω , 24V 2700Ω
6. Blank -- Standard type  
 T -- Special requirement for Tin plated terminal
7. Blank -- Standard type  
 001 -- Coil parallel with diode 1N4007 the diode anode on # 85 terminal  
 002 -- Coil parallel with diode 1N4007 the diode cathode on # 85 terminal
8.  -- Coil voltage (please refer to the coil rating data for the availability)

### »» Contact Rating

Resistive load	70A 14VDC, 25A 28VDC
----------------	----------------------

### »» Coil Rating (DC)

Rated voltage (V)	Rated current ±10 % at 23°C (mA)	Coil resistance ±10 % at 23°C (Ω)	Max. continuous Voltage at 85°C <sup>(1)</sup>	Pick up voltage(Max.) at 23°C	Drop out voltage(Min.) at 23°C	Power consumption at rated voltage
12	133	90	100 % of rated voltage	65 % of rated voltage	10 % of rated voltage	approx. 1.6W
24	66.7	360				

Notes : (1) Continuous contact current at 50A.

### »» Specification

Contact material	AgSnO alloy	
Contact voltage drop <sup>(1)</sup>	Typ. 30mV at 10A	
Insulation resistance <sup>(1)</sup>	20 MΩ Min. (DC 500V)	
Operate time <sup>(1)</sup>	20ms Max.	
Release time <sup>(1)</sup>	20ms Max.	
Dielectric strength <sup>(1)</sup>	Between open contact	: AC 500V , 50/60Hz 1 min.
	Between contact and coil	: AC 500V , 50/60Hz 1 min.
Vibration resistance	Operating extremes	10~500Hz , 5.0G
	Damage limits	10~500Hz , 5.0G
Shock resistance	Operating extremes	10G
	Damage limits	100G
Life expectancy	Mechanical	10,000,000 operations (frequency 18,000 operations/hr)
	Electrical	100,000 operations (frequency 1,200 operations/hr)
Operating ambient temperature	-40~+125°C (no freezing)	
Weight	Approx. 40 g	

Note : (1) Initial value. Operate and release time excluding contact bounce.

## &gt;&gt;&gt; Outline Dimensions

## ◆ 897 (C,D,S)

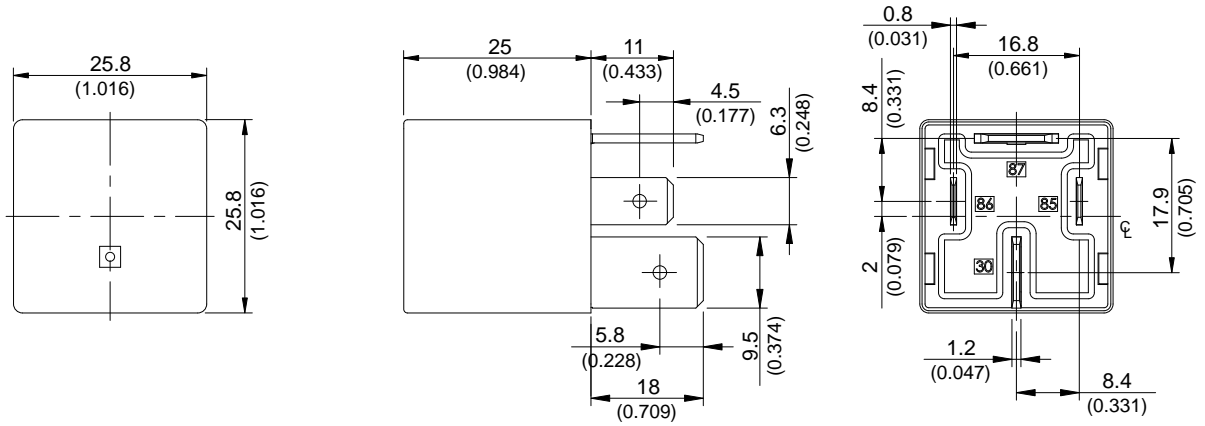

## ◆ 897 (C1,D1,S1)

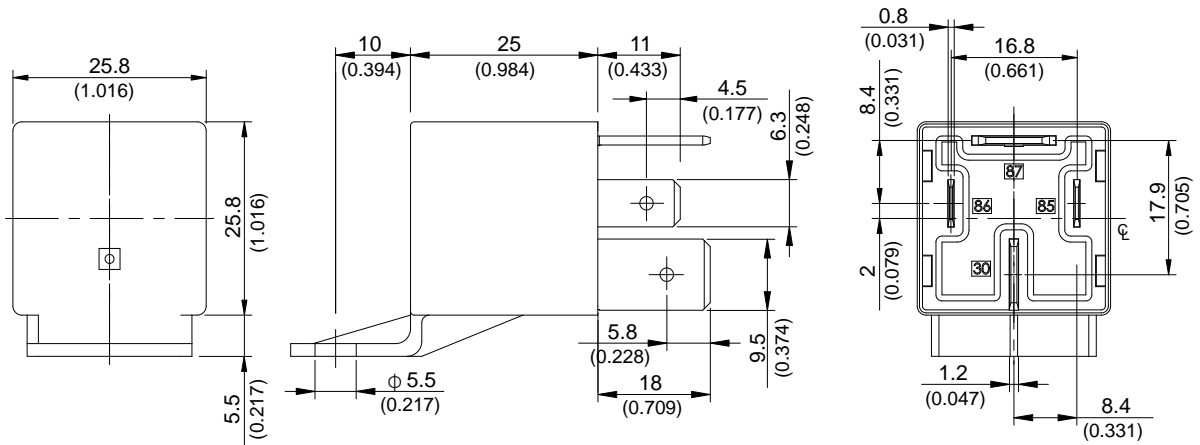

## ◆ 897 (C1S,D1S,S1S)

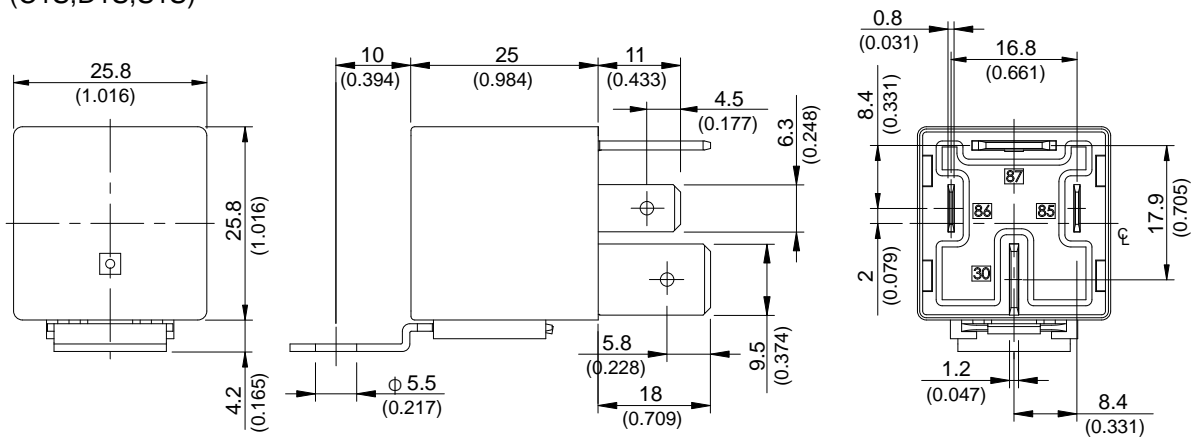

◆ 897 (D1SF)

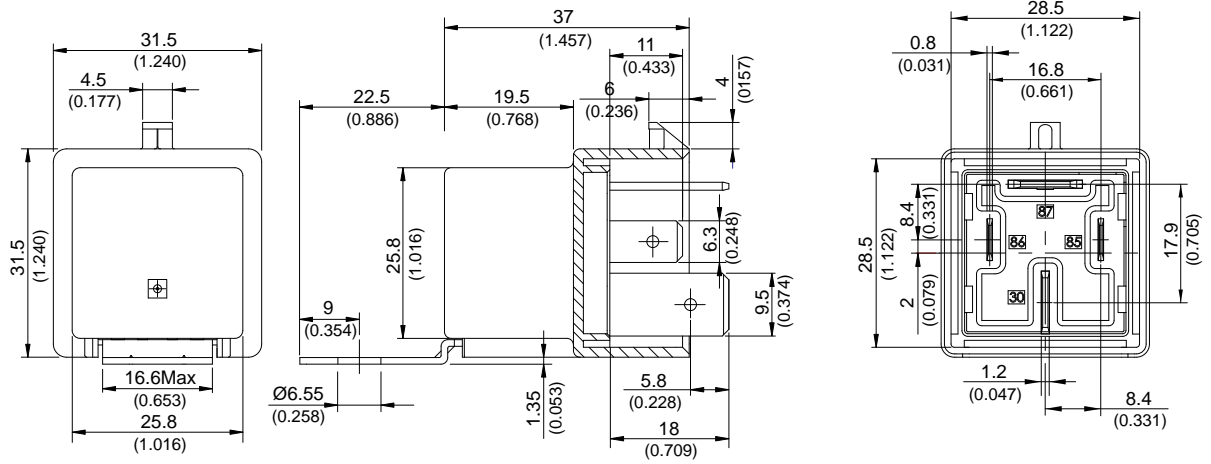

◆ 897 (D1SW)

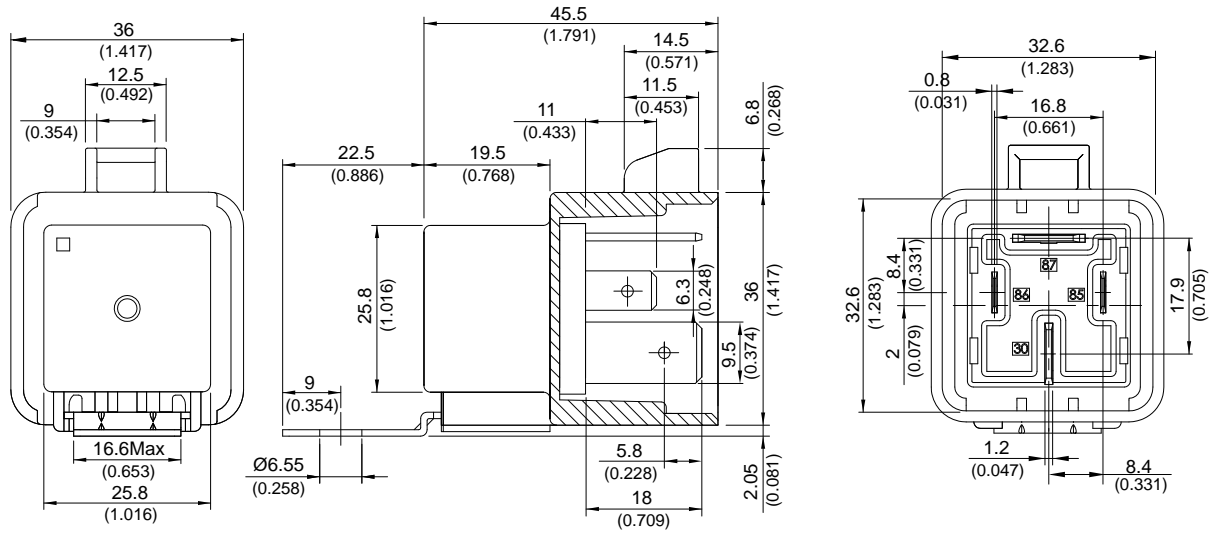

◆ 897 (DUSW)

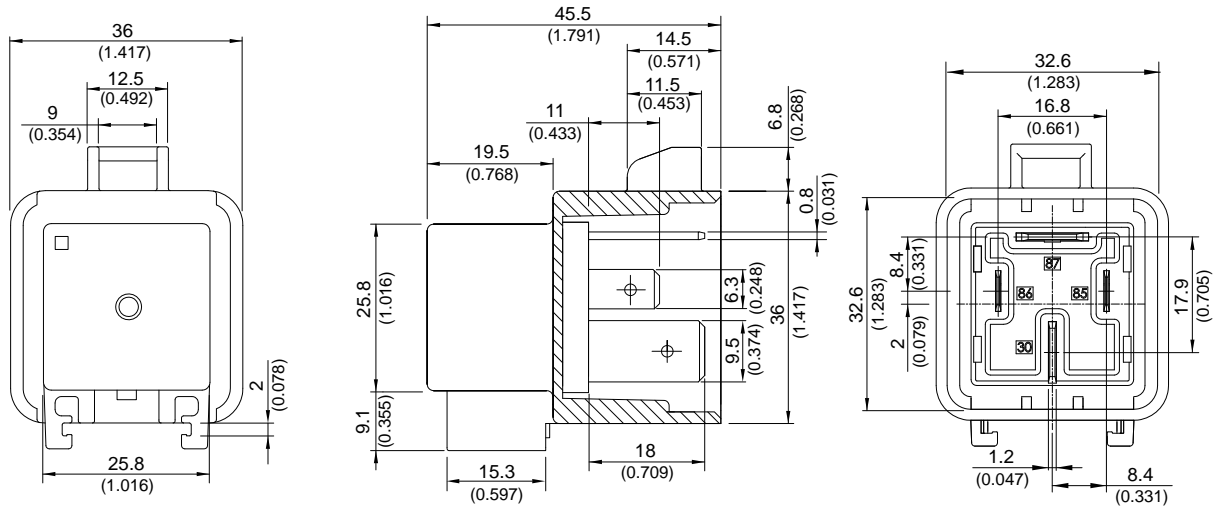



## »» Engineering Data

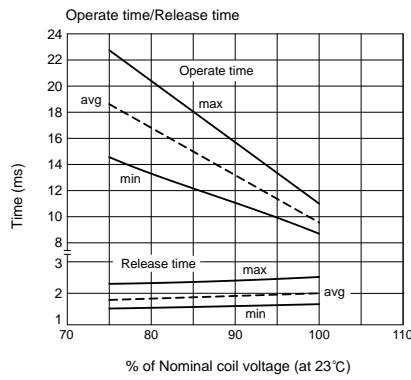
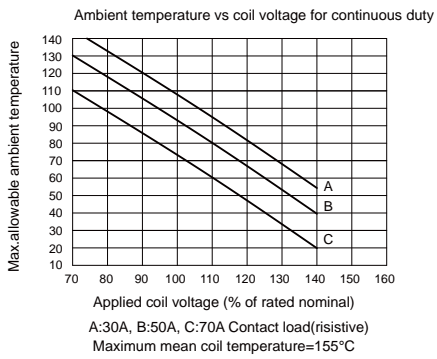
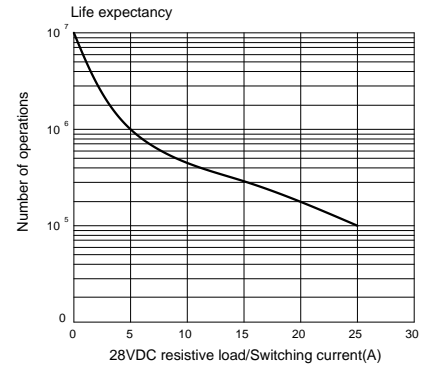
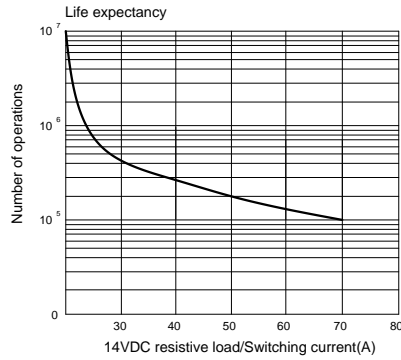
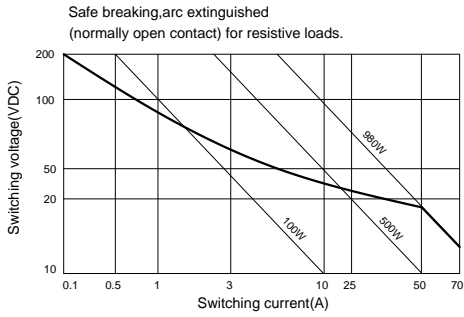



### »» Features

- Mini 280 automotive relay.
- SPNC, SPNO, SPDT contact configurations.
- NO contacts switch 50A resistive load, NC contacts switch 30A resistive load, 100,000 ops., 23°C.
- Operating ambient temperature -40°C to 125°C.
- Available with plain cover, flanged cover, bracketed cover, skirted cover, and weather proof cover.
- Optional resistor or diode for coil transient suppression.
- Complies with RoHS-Directive 2011/65/EU and ELV-Directive 2000/53/EC.

### »» Type List

Terminal style	Contact form	Enclosure style		
		Dust cover	Flux tight	Sealed type washable
Socket terminal	1A (SPNO)	898-1AH-D	898-1AH-C	898-1AH-S
		898H-1AH-D	898H-1AH-C	898H-1AH-S
	1C (SPDT)	898-1CH-D	898-1CH-C	898-1CH-S
		898H-1CH-D	898H-1CH-C	898H-1CH-S

Terminal style	Contact form	Enclosure style	
		Flanged cover (dust cover)	Flanged cover (flux tight)
Socket terminal	1A (SPNO)	898-1AH-D1	898-1AH-C1
		898H-1AH-D1	898H-1AH-C1
	1C (SPDT)	898-1CH-D1	898-1CH-C1
		898H-1CH-D1	898H-1CH-C1

Terminal style	Contact form	Enclosure style	
		Steel bracket (dust cover)	Steel bracket (flux tight)
Socket terminal	1A (SPNO)	898-1AH-D1S	898-1AH-C1S
		898H-1AH-D1S	898H-1AH-C1S
	1C (SPDT)	898-1CH-D1S	898-1CH-C1S
		898H-1CH-D1S	898H-1CH-C1S

Terminal style	Contact form	Designation (provided with)	Enclosure style	
			Steel bracket (dust cover with shroud)	Steel bracket (dust cover with weather proof)
Socket terminal	1C (SPDT)	Resistor	898H-1CH-D1SF-R1	898H-1CH-D1SW-R1

### Ordering Information

898        -    1CH    -    C    -           

1            2            3            4            5            6            7

- |          |  |                             |   |
|----------|--|-----------------------------|---|
| 1. 898   | -- Basic series designation                            | C1S                         | -- Steel bracket (flux tight)   |
| 2. Blank | -- Standard type                                       | S1S                         | -- Steel bracket (sealed type washable)                                     |
| H        | -- High power type                                     | D1SF                        | -- Steel bracket (Dust cover with shroud)                                   |
| 3. 1AH   | -- Single pole normally open, contact material AgSnO   | D1SW                        | -- Steel bracket (Dust cover with weather proof)                            |
| 1BH      | -- Single pole normally closed, contact material AgSnO | DUSW                        | -- Dust cover with weather proof  |
| 1CH      | -- Single pole double throw, contact material AgSnO    | 5. Blank                    | -- Standard type  |
| 4. D     | -- Dust cover  | R1                          | -- Coil parallel with resistor 1/2W for 12V 680Ω, 24V 2700Ω                 |
| C        | -- Flux tight  | 6. Blank                    | -- Standard type  |
| S        | -- Sealed type washable                                | 001                         | -- Coil parallel with diode 1N4007 the diode anode on # 85 terminal         |
| D1       | -- Flanged cover (dust cover)                          | 002                         | -- Coil parallel with diode 1N4007 the diode cathode on # 85 terminal       |
| C1       | -- Flanged cover (flux tight)                          | 7. <input type="checkbox"/> | -- Coil voltage (please refer to the coil rating data for the availability) |
| S1       | -- Flanged cover (sealed type washable)                |                             |   |
| D1S      | -- Steel bracket (dust cover)                          |                             |   |

### Contact Rating

Resistive load	898 1A	898 1B	898 1C
	40A 14VDC	40A 14VDC	NO : 30A 14VDC NC : 20A 14VDC
	898H 1A	898H 1B	898H 1C
	50A 14VDC 20A 28VDC	40A 14VDC 15A 28VDC	NO: 50A 14VDC, 20A 28VDC NC: 30A 14VDC, 15A 28VDC

### Coil Rating (DC)

Rated voltage (V)	Rated current ±10 % at 23°C (mA)	Coil resistance ±10 % at 23°C (Ω)	Max. continuous voltage at 85°C <sup>(1)</sup>	Pick up voltage(Max.) at 23°C	Drop out voltage(Min.) at 23°C	Power consumption at rated voltage
12	133	90	120 % of rated voltage	65 % of rated voltage	10 % of rated voltage	approx. 1.6W
24	66.7	360				

Notes : (1) Without switching the load.

## »» Specification

Contact material	AgSnO alloy	
Contact voltage drop <sup>(1)</sup>	Typ. 50mV at 10A	
Insulation resistance <sup>(1)</sup>	20MΩ Min. (DC 500V)	
Operate time <sup>(1)</sup>	20ms Max.	
Release time <sup>(1)</sup>	20ms Max.	
Dielectric strength <sup>(1)</sup>	Between open contact	: AC 500V , 50/60Hz 1 min.
	Between contact and coil	: AC 500V , 50/60Hz 1 min.
Vibration resistance	Operating extremes	10~500Hz , 5.0G
	Damage limits	10~500Hz , 5.0G
Shock resistance	Operating extremes	10G
	Damage limits	100G
Life expectancy	Mechanical	10,000,000 operations (frequency 18,000 operations/hr)
	Electrical	100,000 operations (frequency 1,200 operations/hr)
Operating ambient temperature	-40~+125°C (no freezing)	
Weight	Approx. 40 g	

Note : (1) Initial value. Operate and release time excluding contact bounce.

## »» Outline Dimensions

### ◆ 898,898H(C,D,S)

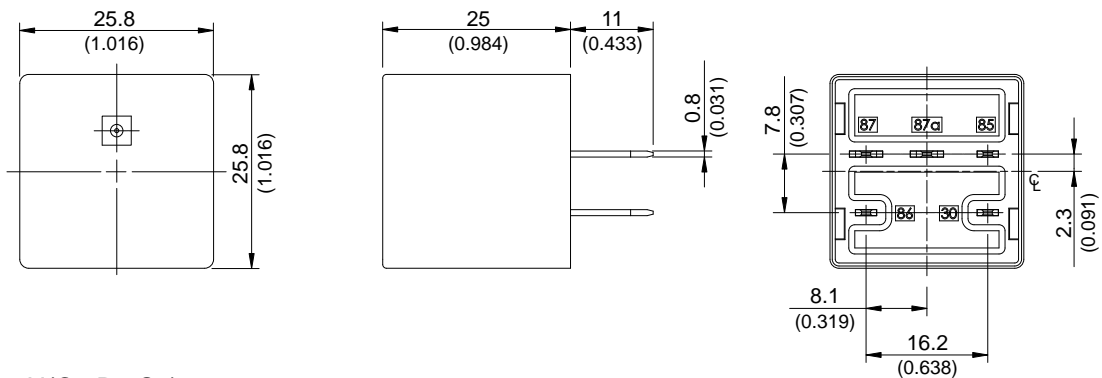

### ◆ 898,898H(C1,D1,S1)

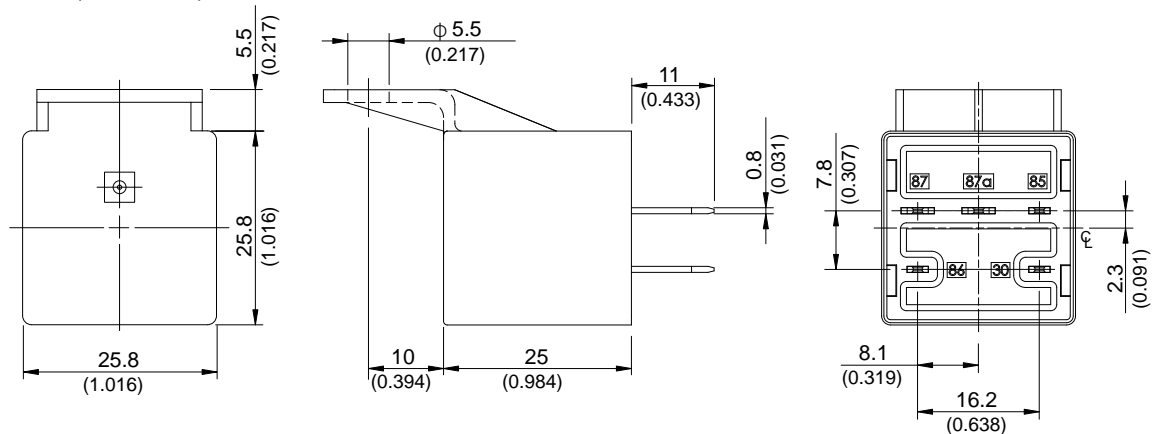

## ◆ 898,898H(C1S,D1S,S1S)

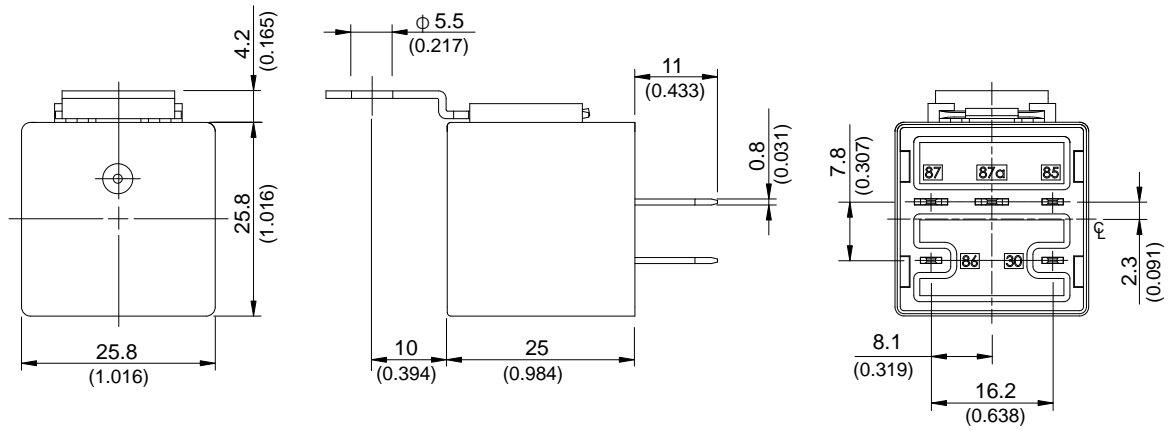

## ◆ 898H (D1SF)

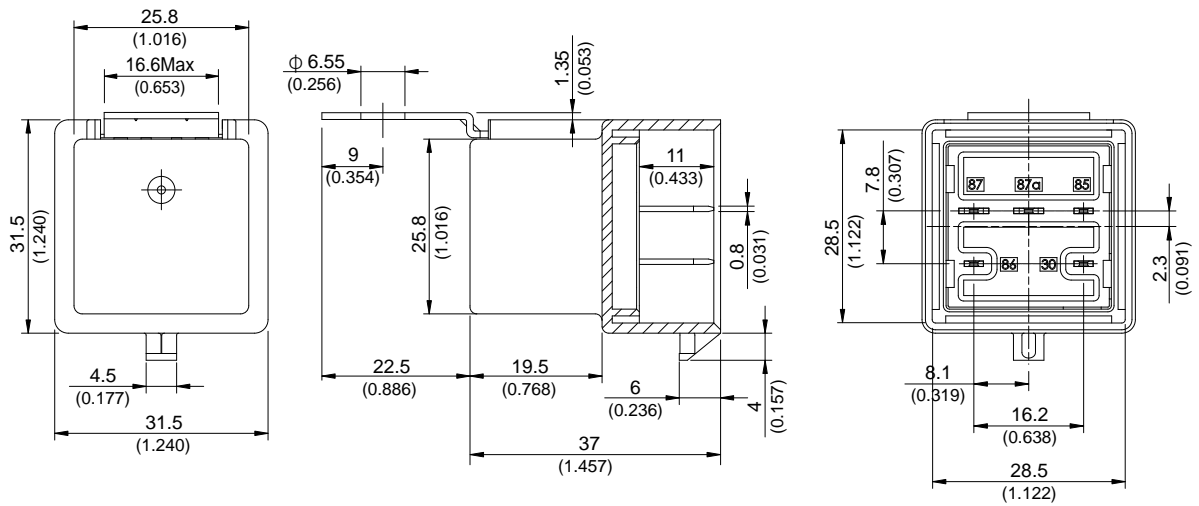

## ◆ 898H (D1SW)

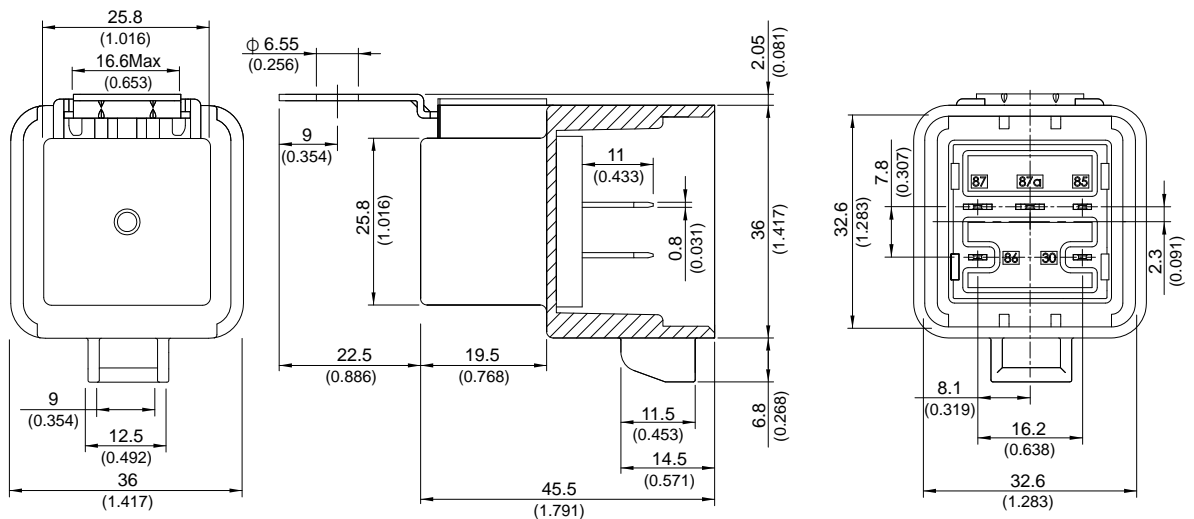

### ◆898H (DUSW)

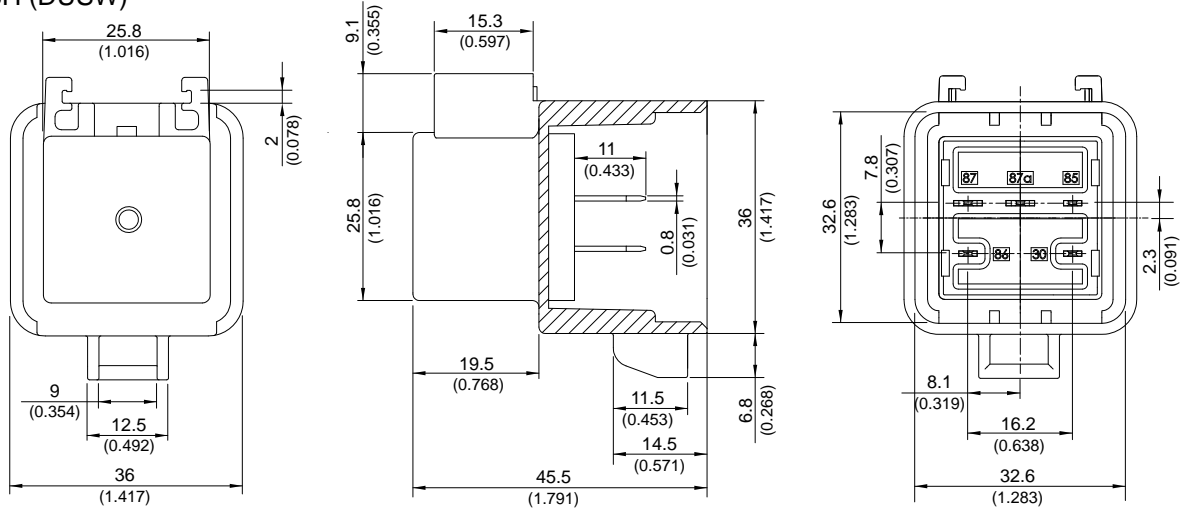

TOLERANCE:  
 LESS THAN: 1(0.039) ±0.1(0.004)  
 5(0.197) ±0.3(0.012)  
 20(0.787) ±0.5(0.020)  
 MORE THAN: 20(0.787) ±1(0.039)

### »» Wiring Diagram BOTTOM VIEW

1A

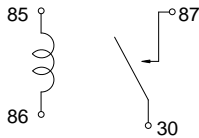

1B

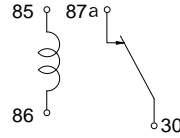

1C

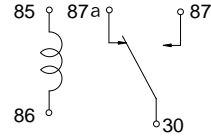

R1

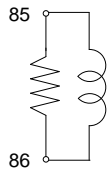

001

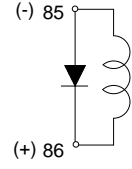

002

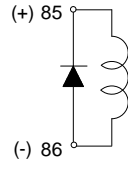

### »» Engineering Data

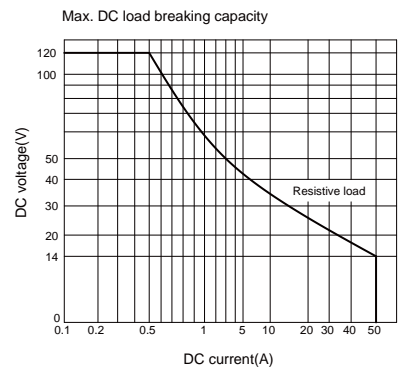
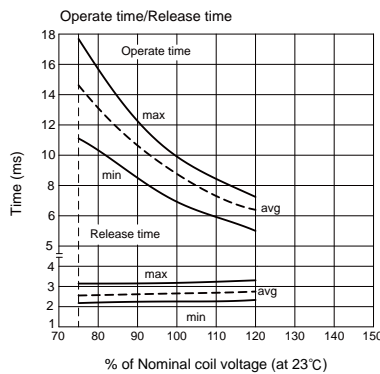
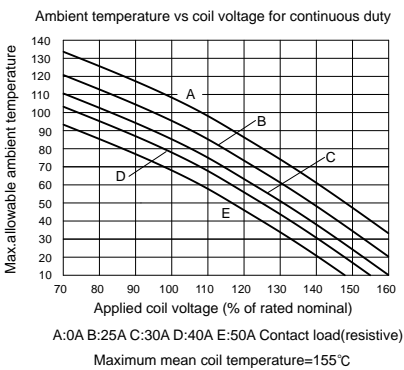
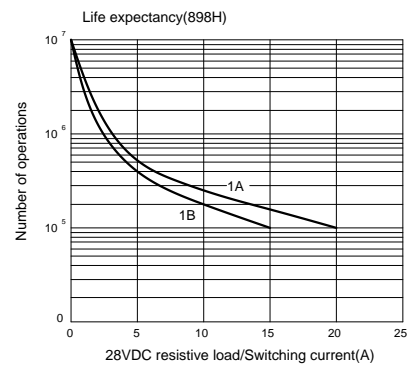
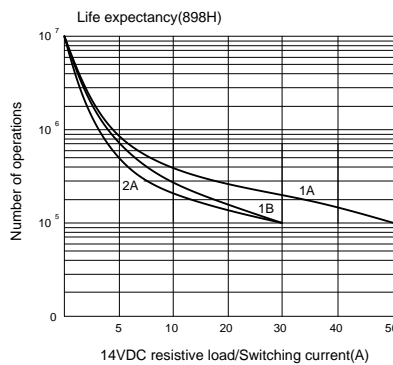
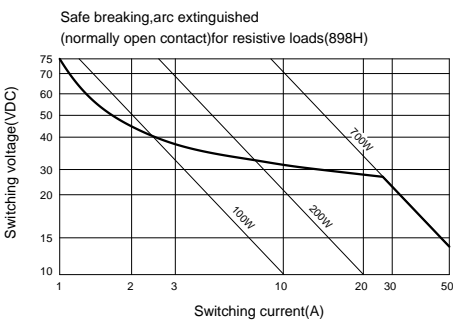



### »» Features

- New generation of heavy duty PCB automotive relay.
- Design for multiple function applications with THT terminals and smallest mounting space.
- Most current relay can be replaced by 1 relay for Relay box / USM / PDM /Smart Junction box, etc.
- Contact rating 30A 14VDC.
- High temperature endurance up to 105°C.
- Mounting space less than micro ISO relay.
- Complies with RoHS-Directive 2011/65/EU and ELV-Directive 2000/53/EC.

### »» Type List

Terminal style	Contact form	Enclosure style		
		Flux tight	Sealed type	Sealed type washable
PCB terminal	1A (SPNO)	905-1AH-C	905-1AH-V	905-1AH-S
		905-1AC-C	905-1AC-V	905-1AC-S
	1C (SPDT)	905-1CH-C	905-1CH-V	905-1CH-S
		905-1CC-C	905-1CC-V	905-1CC-S

### »» Ordering Information

905 - 1A C - S   
 1 2 3 4 5

- |   |   |
|---|---|
| <p>1. 905 -- Basic series designation</p> <p>2. 1A -- Single pole normally open<br/>1C -- Single pole double throw</p> <p>3. C -- Contact material AgNi<br/>H -- Contact material AgSnO</p> | <p>4. C -- Flux tight<br/>V -- Sealed type<br/>S -- Sealed type washable</p> <p>5. <input type="checkbox"/> -- Coil voltage (please refer to the coil rating data for the availability)</p> |
|---|---|

### »» Contact Rating

Resistive load	NO: 30A 14VDC ; ON 5s / OFF 5s ; 100K ops. NC: 20A 14VDC ; ON 5s / OFF 5s ; 100K ops.
Motor load	Cooling fan : 230W / 14VDC ; ON 1s / OFF 5s ; 200K ops.
Lamp load	Head lamp : 120W / 14VDC ; ON 1s / OFF 9s ; 200K ops.
Max. carry current	100A/5sec. (25°C nominal voltage) 60A/10sec. (85°C nominal voltage) 40.5A/30min. (85°C nominal voltage)

### »» Coil Rating (DC)

Rated voltage (V)	Rated current ±10 % at 23°C (mA)	Coil resistance ±10 % at 23°C (Ω)	Max. continuous voltage at 105°C <sup>(1)</sup>	Pick up voltage(Max.) at 23°C	Drop out voltage(Min.) at 23°C	Power consumption at rated voltage
12	60	200	14 V	7.2V	0.6V	approx. 0.72W

Note : (1) Continuous contact current at 25A.

## »» Specification

Contact material	AgSnO alloy <sup>(2)</sup>	
Contact voltage drop <sup>(1)</sup>	Typ. 50mV at 10A	
Operate time <sup>(1)</sup>	10ms Max.	
Release time <sup>(1)</sup>	10ms Max.	
Insulation resistance <sup>(1)</sup>	100MΩ Min. (DC 500V)	
Dielectric strength <sup>(1)</sup>	Between open contact	: AC 500V, 50/60Hz 1 min.
	Between contact and coil	: AC 500V, 50/60Hz 1 min.
Vibration resistance	Operating extremes	10~500Hz , 4.4G
	Damage limits	10~500Hz , 4.4G
Shock resistance	Operating extremes	10G
	Damage limits	100G
Life expectancy	Mechanical	10,000,000 operations (frequency 18,000 operations/hr)
Operating ambient temperature	-40~+105°C (no freezing) <sup>(3)</sup>	
Weight	Approx. 8.6 g	

Note : (1) Initial value. Operate and release time excluding contact bounce.

(2) Contact material of AgNi is also available, for the details please contact Song Chuan.

(3) Ambient temperature of -40~+125°C is also available, for the details please contact Song Chuan.

## »» Outline Dimensions

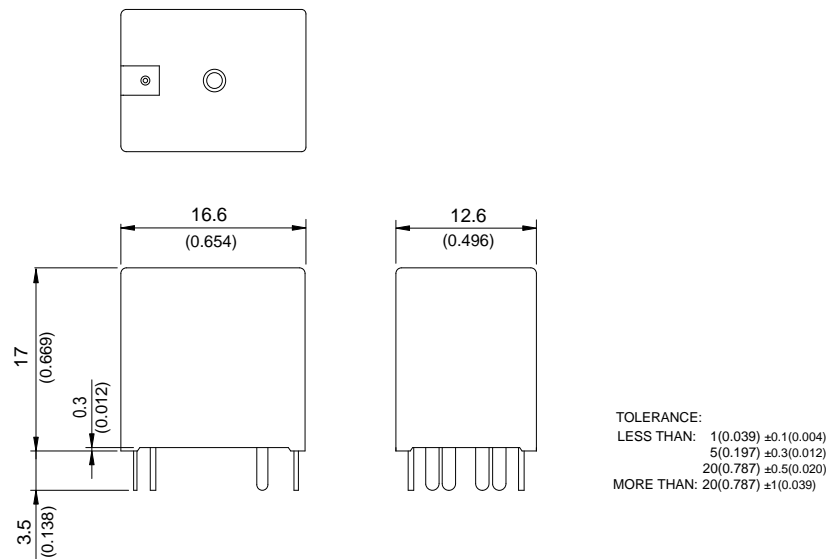

## »» Wiring Diagram

BOTTOM VIEW

1A

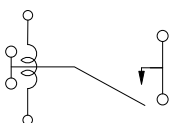

1C

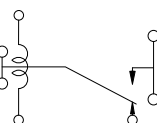

## »» PC Board Layout

BOTTOM VIEW

